

**JVC**

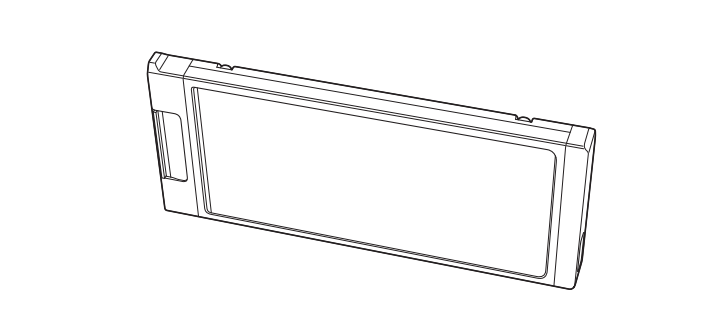

H.265/HEVC 使用说明书  
流媒体适配器 INSTRUCTIONS  
**KA-EN200EC** MANUEL D'INSTRUCTIONS  
MANUAL DE INSTRUCCIONES  
BEDIENUNGSANLEITUNG

H.265/HEVC STREAMING ADAPTER ISTRUZIONI  
**KA-EN200G** ИНСТРУКЦИЯ ПО ЭКСПЛУАТАЦИИ

<b>For Customer Use:</b> Enter below the Serial No. which is located on the body. Retain this information for future reference.	
Model No.   KA-EN200G	
Serial No. _____	
	B5A-3431-10

感谢您购买本产品。

在操作之前，请阅读本产品和摄像机的“使用说明书”手册。使用产品前请仔细阅读本使用说明书，并请妥善保管。此为H.265/HEVC编码适配器，可安装到我们兼容的摄像机上并用于高清流媒体分发。

如果相机固件与本机不兼容，则需要更新相机固件。 请参阅我公司网站。

#### ◆安全注意事项

- 和本产品为精密仪器，避免受到振动或撞击。
- 使用后立即从摄像机中取出本产品时，请注意高温。

#### ◆妥善使用本机的注意事项

- 对于在使用本产品期间导致的任何直接或间接损坏或数据丢失，我公司概不负责。
- 本产品不适用于要求高可靠性以及与人类生活相关的设备和装置，如医疗设备、核设备和航空航天设备。
- 在靠近收音机、电视和音频设备的情况下，本产品可能会发生故障。
- 在将本机安装至相机或从相机上拆下之前，请关闭相机电源。有关详细信息，请参阅相机手册或固件更新信息。
- USB端子仅可用于连接到我们的兼容相机。 请勿连接到其他USB设备。

#### ◆故障排除

- 相机无法识别本机。  
⇒确保已将其正确插入相机。

#### ◆本手册的内容

- JVCKENWOOD Corporation 保留所有权利。未经许可，严禁复制或转载本手册的全部或部分内容。
- 本手册的图解设计、规格和其他内容可随时更改，恕不事先通知。
- 本说明手册内包含的其他产品和公司名称是各个公司的商标和／或注册商标。本手册中省略了™和®等标记。

原 产 地：泰国制造

销售者名称：北京数码博奕科贸有限公司

地 址：北京市海淀区大柳树富海中心3号楼1702室

出 版 日：2020年4月1日

JVC建伍株式会社

Thank you for purchasing this product.

Before operating, please read the "INSTRUCTIONS" manuals of this product and the camera recorder.

This is a H.265/HEVC encoding adapter that can be mounted to our compatible cameras and used for HD streaming distribution.

If the camera firmware is not compatible with this unit, you need to update the camera firmware. Refer to our website.

#### ◆ Safety Precautions

- Avoid shock or impact to this product as they are precision instruments.
- Be careful of the high temperature when removing this product from the camera immediately after use.

#### ◆ Precautions for Proper Use

- We are not liable for any direct or indirect damages or loss of data that occur during the use of this product.
- This product is not intended for use in equipment and devices that require high reliability and those related to human lives such as medical equipment, nuclear equipment, and aerospace equipment.
- This product may malfunction near the presence of radios, televisions, and audio equipment.
- Before mounting or removing this unit to the camera, turn off the camera. For details, check the camera's manual or firmware update information.
- The USB terminal only can be used for connection to our compatible cameras. Do not connect to other USB devices.

#### ◆ Troubleshooting

- The camera does not recognize this unit.  
⇒Make sure that it is properly inserted into your camera.

#### ◆ Content of this manual

- All rights reserved by JVCKENWOOD Corporation. Unauthorized duplication or reprinting of this manual, in whole or in part, is strictly prohibited.
- Illustrated designs, specifications and other contents of this manual are subject to change for improvement without prior notice.
- Other product and company names included in this instruction manual are trademarks and/or registered trademarks of their respective companies. Marks such as ™ and ® have been omitted in this manual.

Supplier's Declaration of Conformity	
Model Number	: KA-EN200G
Trade Name	: JVC
Responsible party	: JVCKENWOOD USA Corporation
Address	: 500 Valley Road, Suite 203 Wayne, NJ 07470
Telephone Number	: 973-317-5000
This device complies with Part 15 of the FCC Rules. Operation is subject to the following two conditions: (1) This device may not cause harmful interference, and (2) this device must accept any interference received, including interference that may cause undesired operation.	

Changes or modifications not approved by JVC could void the user's authority to operate the equipment. This equipment has been tested and found to comply with the limits for a Class A digital device, pursuant to Part 15 of the FCC Rules. These limits are designed to provide reasonable protection against harmful interference when the equipment is operated in a commercial environment. This equipment generates, uses, and can radiate radio frequency energy and, if not installed and used in accordance with the instructions, may cause harmful interference to radio communications. Operation of this equipment in a residential area is likely to cause harmful interference in which case the user will be required to correct the interference at his own expense.	
--	--

<b>Dear Customer</b> This apparatus is in conformance with the valid European directives and standards regarding electromagnetic compatibility and electrical safety. European representative of JVCKENWOOD Corporation is: JVCKENWOOD Deutschland GmbH Konrad-Adenauer-Allee 1-11, 61118 Bad Vilbel, GERMANY	
--	--

Nous vous remercions d'avoir acheté ce produit. Avant de commencer, veuillez lire les manuels “MANUEL D'INSTRUCTIONS” de ce produit et du caméscope. Il s'agit d'un adaptateur d'encodage H.265/HEVC qui peut être monté sur nos caméras vidéo compatibles et utilisé pour la distribution en streaming HD. Si le micrologiciel de la caméra vidéo n'est pas compatible avec cet appareil, vous devez mettre à jour le micrologiciel de la caméra vidéo. Se référer à notre site Web.	
---	--

#### ◆ Précautions de sécurité

- Éviter les chocs et les impacts sur les disques ce produit, car ce sont des instruments de précision.
- Faire attention à la température élevée lors du retrait de ce produit de l'appareil photo immédiatement après utilisation.

#### ◆ Précautions d’emploi

- Nous ne sommes pas responsables des dommages directs ou indirects, ni de la perte de données lors de l'utilisation de ce produit.

- Ce produit n'est pas destiné à être utilisé dans des équipements et des appareils nécessitant une grande fiabilité et dans des domaines liés à la vie humaine, tels que les équipements médicaux, les équipements nucléaires et les équipements aérospatiaux.
- Ce produit peut ne pas fonctionner correctement en présence de radios, de téléviseurs et d'équipements audio.
- Avant de monter ou de démonter l'appareil à la caméra vidéo, éteignez la caméra vidéo. Pour plus d'informations, consultez le mode d'emploi ou les informations de mise à jour du micrologiciel.
- La borne USB ne peut être utilisée que pour la connexion à nos caméras vidéo compatibles. Ne vous connectez pas à d'autres périphériques USB.

#### ◆ Dépannage

- La caméra vidéo ne reconnaît pas cet appareil.  
⇒Assurez-vous qu'il est correctement inséré dans votre caméra vidéo.

#### ◆ Contenu du présent manuel

- Tous droits réservés par JVCKENWOOD Corporation. La copie ou la reproduction non autorisées de ce manuel, en tout ou en partie, est strictement interdite.
- Les modèles illustrés, les spécifications et toute autre information dans le présent manuel sont susceptibles de modifications et améliorations sans préavis.
- D'autres noms de produits et de sociétés figurant dans ce manuel d'instructions sont des marques commerciales et/ou des marques commerciales déposées de leurs sociétés respectives. Les symboles tels que ™ et ® ont été omis dans ce manuel.

Déclaration de conformité du fournisseur	
Numéro de modèle	: KA-EN200G
Nom de marque	: JVC
Personne responsable	: JVCKENWOOD USA Corporation
Adresse	: 500 Valley Road, Suite 203 Wayne, NJ 07470
Numéro de téléphone	: 973-317-5000
Cet ensemble se conforme à la partie 15 des règles de la FCC (Federal Communications Commission). Le fonctionnement est sujet aux deux conditions suivantes <span> </span> : (1) Cet appareil ne peut pas causer d'interférences nuisibles, et (2) cet appareil doit accepter toute interférence reçue, comprenant des interférences qui peuvent causer un mauvais fonctionnement.	

Des changements ou modifications non approuvés par JVC peuvent annuler le droit de l'utilisateur de faire fonctionner l'appareil. Cet appareil a été testé et il a été reconnu qu'il se conforme aux limites concernant l'appareillage informatique de classe A correspondant à la partie 15 des règles de la FCC. Ces limites sont conçues pour fournir une protection raisonnable contre les interférences dangereuses lorsque l'équipement est utilisé dans un environnement commercial. Cet appareil génère, utilise et peut émettre de l'énergie des fréquences radio et, s'il n'est pas installé et utilisé selon les instructions du fabricant, peut causer des interférences nuisibles en communications radio. L'utilisation de cet équipement dans une zone résidentielle est susceptible de causer des interférences néfastes, auquel cas l'utilisateur devra prendre des mesures à ses propres frais.	
---	--

<b>Cher(e) client(e),</b> Cet appareil est conforme aux directives et normes européennes en vigueur concernant la compatibilité électromagnétique et à la sécurité électrique. Représentant européen de la société JVCKENWOOD Corporation <span> </span> : JVCKENWOOD Deutschland GmbH Konrad-Adenauer-Allee 1-11, 61118 Bad Vilbel, ALLEMAGNE	
---	--

Gracias por adquirir este producto. Antes de iniciar el uso, por favor, consulte los “MANUAL DE INSTRUCCIONES” de este producto y de la cámara grabadora. Este es un adaptador de codificación H.265/HEVC que puede montarse en nuestras cámaras compatibles y usarse para la difusión de transmisiones en HD. Si el firmware de la cámara no es compatible con esta unidad, deberá actualizar el firmware de la cámara. Visite nuestra página web.	
---	--

#### ◆ Precauciones de seguridad

- Evite golpes o impactos de la unidad este producto dado que son instrumentos de precisión.
- Tenga cuidado de la alta temperatura cuando extraiga este producto de la cámara inmediatamente después del uso.

#### ◆ Precauciones para un uso adecuado

- No nos hacemos responsables de ningún daño directo o indirecto o de las pérdidas de datos que se produzcan durante el uso de este producto.
- Este producto no está destinado al uso en equipos y dispositivos que requieran una alta fiabilidad y aquellos relacionados con la vida humana, como equipos médicos, equipos nucleares y equipos aeroespaciales.
- Este producto podría no funcionar correctamente cerca de la presencia de radios, televisores y equipos de audio.
- Antes de conectar o extraer esta unidad de la cámara, apague la cámara. Para obtener más información, consulte el manual de la cámara o la información de actualización del firmware.
- El terminal USB solo se puede utilizar para su conexión a nuestras cámaras compatibles. No lo conecte a otros dispositivos USB.

#### ◆ Resolución de problemas

- La cámara no reconoce esta unidad.  
⇒Asegúrese de que este esté bien introducido en la cámara.

#### ◆ Índice de este manual

- Todos los derechos reservados de JVCKENWOOD Corporation. La duplicación o la reimpresión no autorizadas de este manual, total o parcialmente, están estrictamente prohibidas.
- Los diseños ilustrados, las especificaciones y otros contenidos de este manual están sujetos a cambios para mejoras sin aviso previo.
- Otros nombres de productos y empresas incluidos en este manual de instrucciones son marcas comerciales y/o marcas comerciales registradas de sus respectivas empresas. Las marcas como ™ y ® se han omitido en este manual.

<b>Apreciado cliente,</b> Este aparato cumple con las normativas y normas europeas respecto a la seguridad eléctrica y a la compatibilidad electromagnética. El representante europeo de JVCKENWOOD Corporation es: JVCKENWOOD Deutschland GmbH Konrad-Adenauer-Allee 1-11, 61118 Bad Vilbel, ALEMANIA	
---	--

Vielen Dank für den Kauf dieses Produkts. Lesen Sie vor der Inbetriebnahme die „BEDIENUNGSANLEITUNG“ für dieses Gerät und den Kamera-Recorder. Dies ist ein H.265/HEVC-Codierungsadapter, der an unsere kompatiblen Kameras angeschlossen und für die Verteilung von HD-Streams verwendet werden kann. Wenn die Kamera-Firmware nicht mit diesem Gerät kompatibel ist, müssen Sie sie aktualisieren. Beachten Sie dazu bitte unsere Website.

#### ◆ Sicherheitsmaßnahmen

- Vermeiden Sie Stöße oder Schläge auf die dieses Gerät, da es sich um Präzisionsinstrumente handelt.
- Achten Sie auf die hohen Temperaturen, wenn Sie das Gerät unmittelbar nach Gebrauch aus der Kamera nehmen.

#### ◆ Vorsichtsmaßnahmen beim Einsatz des Systems

- Wir haften nicht für direkte oder indirekte Schäden oder Datenverluste, die bei der Verwendung dieses Geräts auftreten.
- Dieses Produkt ist nicht für den Einsatz in Anlagen und Geräten bestimmt, die eine hohe Zuverlässigkeit erfordern, und nicht in solchen, die mit Menschenleben in Verbindung stehen, wie etwa medizinische Geräte, Nuklearanlagen und Luftfahrtanlagen.
- Dieses Produkt kann in der Nähe von Radios, Fernsehgeräten und Audiogeräten Funktionsstörungen aufweisen.
- Schalten Sie die Kamera aus, bevor Sie das Gerät mit der Kamera verbinden oder es entfernen. Weitere Informationen finden Sie im Handbuch der Kamera oder in den Firmware-Aktualisierungsinformationen.
- Über den USB-Anschluss können nur unsere kompatiblen Kameras angeschlossen werden. Schließen Sie keine anderen USB-Geräte an.

#### ◆ Fehlersuche

- Die Kamera erkennt das Gerät nicht.  
⇒Stellen Sie sicher, dass es richtig in Ihre Kamera eingesetzt ist.

#### ◆ Inhalt dieses Handbuchs

- Alle Rechte vorbehalten von der JVCKENWOOD Corporation. Unerlaubte Vervielfältigung oder Nachdruck dieses Handbuchs als Ganzes oder in Teilen ist strengstens untersagt.
- Anschauungsbilder, technische Daten und andere in diesem Handbuch vermittelte Informationen können im Sinne einer stetigen Produktverbesserung ohne vorherige Ankündigung geändert werden.
- Andere Produkt- und Unternehmensnamen, die in diesem Handbuch verwendet werden, sind Warenzeichen und/oder eingetragene Warenzeichen ihrer jeweiligen Unternehmen. Zeichen wie ™ und ® wurden in diesem Handbuch ausgelassen.

<b>Sehr geehrter Kunde,</b> Sehr geehrte Kundin, dieses Gerät stimmt mit den gültigen europäischen Richtlinien und Normen bezüglich elektromagnetischer Verträglichkeit und elektrischer Sicherheit überein. Die europäische Vertretung für die JVCKENWOOD Corporation ist: JVCKENWOOD Deutschland GmbH Konrad-Adenauer-Allee 1-11, 61118 Bad Vilbel, DEUTSCHLAND	
--	--

<b>Importer (EU only)</b> JVCKENWOOD U.K. Limited 12 Priestley Way, London NW2 7BA, UNITED KINGDOM	
<b>Importeur (Nur EU)</b> JVCKENWOOD Deutschland GmbH Konrad-Adenauer-Allee 1-11, 61118 Bad Vilbel, DEUTSCHLAND	
<b>Importatore (Solo EU)</b> JVCKENWOOD Italia S.p.A. Via G. Sirtori 7/9, 20129 Milano, ITALIA	

**Importeur (Alleen EU)**  
JVCKENWOOD Belgium N.V.  
Leuvensesteenweg 248J, 1800 Vilvoorde, BELGIQUE

**Importeur (Alleen EU)**  
JVCKENWOOD Europe B.V.  
Amsterdamseweg 37, 1422 AC Uithoorn, NEDERLAND

**Manufacturer**  
JVCKENWOOD Corporation  
3-12, Moriya-cho, Kanagawa-ku, Yokohama-shi, Kanagawa, 221-0022, JAPAN

Grazie per aver acquistato questo prodotto.

Prima dell'uso, leggere attentamente i manuali di “ISTRUZIONI” di questo prodotto e del registratore videocamera.

Questo è un adattatore di codifica H.265/HEVC che può essere montato sulle nostre videocamere compatibili e utilizzato per la distribuzione di streaming HD.

Se il firmware della videocamera non è compatibile con questa unità, è necessario aggiornare il firmware della videocamera. Fare riferimento al nostro sito web.

**◆Precauzioni di sicurezza**

- Evitare di provocare shock o urti all’a questo prodotto in quanto sono strumenti di precisione.
- Prestare attenzione all’alta temperatura quando si rimuove questo prodotto dalla videocamera immediatamente dopo l’uso.

**◆Precauzioni per un Uso corretto**

- Non siamo responsabili di eventuali danni diretti o indiretti o di perdite di dati che si verificano durante l’uso di questo prodotto.
- Questo prodotto non è destinato per l’uso in apparecchiature e dispositivi che richiedono alta affidabilità e in quelli correlati alla vita umana, per esempio attrezzature mediche, apparecchiature nucleari e apparecchiature aerospaziali.
- Questo prodotto potrebbe non funzionare correttamente in presenza di radio, televisori e dispositivi audio.
- Prima di montare questa unità sulla videocamera o di rimuoverla, spegnere la videocamera. Per i dettagli, consultare il manuale della videocamera o le informazioni di aggiornamento firmware.
- Il terminale USB può essere utilizzato solo per il collegamento alle nostre videocamere compatibili. Non collegare ad altri dispositivi USB.

**◆Risoluzione dei problemi**

- La videocamera non riconosce quest’unità.
⇒Assicurarsi che sia correttamente inserita nella videocamera.

**◆Contenuto di questo manuale**

- Tutti i diritti riservati da JVCKENWOOD Corporation. La duplicazione non autorizzata o la ristampa del presente manuale, in tutto o in parte, è severamente vietata.
- Al fine di migliorare il prodotto, i design illustrati, le specifiche ed altre informazioni contenute in questo manuale sono soggetti a cambiamenti senza preavviso.
- Gli altri nomi di prodotti e aziende compresi nel presente manuale di istruzioni sono marchi e/o marchi registrati delle rispettive società. Nel presente manuale sono stati omessi marchi quali ™ e ©.

<b>Gentile Cliente,</b> <div>Questa apparecchiatura è conforme alle direttive e alle norme europee relative alla compatibilità elettromagnetica e alla sicurezza elettrica. Il rappresentante europeo di JVCKENWOOD Corporation è: JVCKENWOOD Deutschland GmbH Konrad-Adenauer-Allee 1-11, 61118 Bad Vilbel, GERMANIA</div>
---

Благодарим Вас за приобретение этого изделия.
Перед началом работы, пожалуйста, прочитайте „ИНСТРУКЦИЯ ПО ЭКСПЛУАТАЦИИ“ по эксплуатации для данного изделия и видеокамеры.
Это адаптер кодирования H.265/HEVC, который можно устанавливать в наши совместимые камеры и использовать для распределения потоковой трансляции в HD-качестве.
Если микропрограмма камеры несовместима с данным устройством, необходимо обновить микропрограмму камеры.
См. на нашем сайте.

**◆Техника безопасности**

- Не допускайте ударной нагрузки на это изделие, так как они являются высокоточными приборами.
- Будьте осторожны при извлечении этого изделия из камеры, так как сразу после использования изделие имеет высокую температуру.

**◆Меры предосторожности при работе**

- Мы не несем ответственности за любые прямые или косвенные убытки или потерю данных, которые произошли во время использования этого изделия.
- Это изделие не предназначено для использования в оборудовани и устройствах, которые требуют высокой надежности и связаны с человеческими жизнями, таких как медицинское, ядерное и космическое оборудование.
- Это изделие может работать со сбоями вблизи радиоприемников, телевизоров и аудиооборудования.
- Перед установкой данного устройства в камеру или извлечением его из камеры выключите камеру. Для получения дополнительной информации ознакомьтесь с руководством по эксплуатации камеры или информацией об обновлении микропрограммы.
- Разъем USB можно использовать только для подключения к нашим совместимым камерам. Не подключайте к другим устройствам USB.

**◆Поиск и устранение неисправностей**

- Камера не распознает это устройство.
⇒Убедитесь в том, что оно правильно вставлено в камеру.

**◆Содержание данной инструкции**

- Все права защищены корпорацией JVCKENWOOD Corporation. Несанкционированное копирование или перепечатка данного руководства, целиком или частично, строго запрещена.
- Внешний вид, технические характеристики и другая информация, описанные в данной инструкции, могут изменяться в целях улучшения без предварительного уведомления.
- Названия товаров других компаний, упоминаемые в данном руководстве, являются торговыми марками или зарегистрированными торговыми марками соответствующих компаний. Символы ™ и © в данном руководстве не используются.

<b>Уважаемый клиент,</b> <div>Данное устройство соответствует действительным Европейским директивам и стандартам по электромагнитной совместимости и электрической безопасности. Представительство компании JVCKENWOOD Corporation в Европе: JVCKENWOOD Deutschland GmbH Konrad-Adenauer-Allee 1-11, 61118 Bad Vilbel, ГЕРМАНИЯ</div>
---

Item	Description
Power	DC 5 V - 17 V
Power consumption	3.5 W (Max)
Dimensions	88 mm (W) × 8.4 mm (H) × 39.8 mm (D)
Mass	Approx. 40 g
Allowable operating temperature	0 °C to 40 °C (32 °F to 104 °F)
Allowable operating humidity	30 %RH to 80 %RH
Allowable storage temperature	-20 °C to 50 °C
[USB] terminal	USB Type-C
Accessories	Instruction manual, warranty card: KA-EN200EC, KA-EN200G (for U.S.A.)

## 关于环保使用期限



环保使用期限

- 此图标表示了中华人民共和国的法律所规定的环保使用期限。只要用户在使用本产品时遵守注意事项中的各项规定，从制造日期开始到此图标标出的期限为止（环保使用期限）既不会污染环境也不会产生对人体有害的物质。

#### 关于产品中的有害物质

部件名称	有害物质					
	铅 (Pb)	汞 (Hg)	镉 (Cd)	六价铬 (Cr (VI))	多溴联苯 (PBB)	多溴二苯醚 (PBDE)
线路板组件	×	○	○	×	○	○
机箱	×	○	○	×	○	○
其他附件	×	○	○	×	○	○

本表格依据 SJ/T11364 的规定编制。
○：表示该有害物质在该部件所有均质材料中的含量均在 GB/T26572 规定的限量要求以下。
×：表示该有害物质至少在该部件的某一均质材料中的含量超出 GB/T26572 规定的限量要求。

## 软件使用许可合同

J V C 建伍株式会社（以下简称“许可方”）拥有本产品中的组装软件（以下简称“许可软件”）的著作权或再使用许可权。本合同就用户使用本“许可软件”的条件作出规定。用户必须在同意本软件使用许可合同的条件下使用该“许可软件”。当用户（以下简称“使用方”）开始使用安装了“许可软件”的本产品时，即视本合同生效。

### 第一条（总则）

许可方同意向使用方提供限于日本国内非独占且不可转让的本许可软件使用权（第三条第1项规定的例外除外）。

### 第二条（使用权）

- 本合同中产生的使用权是指在本产品中使用许可软件的权利。
- 使用方不得复制、复印、修改、追加、更改翻译或者出租本许可软件以及部分或全部的有关资料。
- 本许可软件仅限于个人使用范围。无论是否盈利或其他任何目的，任何人都无权对本许可软件进行发行、许可使用或再许可使用权。
- 使用方必须按照本许可软件的使用说明书或帮助文件中记载的使用方法使用本许可软件，不得利用全部或部分的本许可软件来使用或复制违反著作权法等法律规定的数据。

### 第三条（许可条件）

- 使用方在转让本产品时，可以同时将内在的本许可软件（包括相关资料，更新版，升级版）的使用权进行转移。但是，作为转移条件，使用方不能保留原版及任何复制品和相关资料，以及让转让接受方遵守本软件使用许可合同的规定。
- 使用方无权对本许可软件进行逆向工程、反汇编、逆编译程序等编码分析工作。

### 第四条（许可软件的权利）

- 本许可软件以及其相关资料的著作权等所有的权利归属于许可方或向许可方提供本许可软件的使用权和再使用权的原权利方（以下简称“原权利方”）。除了本软件使用合同所规定的许可软件以及相关资料的使用权，使用方不拥有任何其他权利。
- 使用方在使用本许可软件时，必须遵守有关的著作权及知识产权的法律。

### 第五条（许可方的责任限制）

- 对于使用方在行使本合同规定的使用权中给使用方或第三方造成的损害，许可方以及原权利方不承担任何责任。但如存在有关法律时除
- 许可方不保证本“许可软件”的产品性质、兼容性以及是否符合特定的目的。

### 第六条（对于第三方的责任）

使用方在使用本许可软件中，因著作权、专利权以及其他知识产权侵害而与第三方发生纠纷时，使用方自费进行解决，不给许可方以及原权利方造成不良影响。

### 第七条（保密）

对于本合同提供的许可软件、其他有关资料等信息及本合同中未公开的内容，使用方需保守秘密，没有许可方的同意不得向第三方公开或泄露。

### 第八条（合同的终止）

当使用方发生以下情况，许可方可以立即终止本合同，并有权向使用方要求因此而造成的损害赔偿。
（1）违反了本合同的规定
（2）受查封、诉前财产保全、先予执行以及其他强制执行申请。

### 第九条（许可软件的废弃）

根据上述规定当本合同被终止时，使用方需在合同终止日起2周内对许可软件、有关资料以及其他复制品进行废弃处理。

### 第十条（出口限制）

- 使用方了解本许可软件为日本以及美国的出口限制对象。
- 使用方同意本软件服从一切有关国际法以及国内法（包括美国的出口管理规定、美国、日本以及其他政府机关规定的终端用户、终端用户的使用和有关于出口对象国的规定）。
- 如果用户为美利坚合众国的机构（“政府”），则用户承认许可方的陈述，即：本授权软件是联邦并购法规（FAR）2.101部分（g）中所定义的“商业项目”，其包含未发表的“商用计算机软件”，意为FAR法规12.212部分中所使用的项目。本软件仅为用户授予使用权限，该权限与授权人依据本协议的条款授予所有商用最终用户的权限相同。

### 第十一条（其他）

- 即使本合同的部分内容因法律规定而无效，不影响其他内容的有效性。
- 对于本合同没有予以规定的内容或在解释本合同中存在争议时，许可方和使用方应诚意协商解决。
- 许可方和使用方在基于日本法律履行本合同过程中因本合同的权利和义务而产生争议时，双方同意由东京地方法庭作为第一审的专属合意管辖法庭。

## Software License Agreement

The software embedded in the Product (hereinafter the “Licensed Software”) provided by JVCKENWOOD Corporation (hereinafter the “Licensor”) is copyrighted to or sublicensable by the Licensor, and this Agreement provides for the terms and conditions which Users shall follow in order to use the Licensed Software. The User shall use the Licensed Software by agreeing with the terms of this Software License Agreement. This Agreement shall be deemed completed at the time the User (hereinafter the “User”) initially used the Product in which the “Licensed Software” is embedded.

#### Article 1 General Provision

The Licensor shall grant to the User a non-exclusive and non-transferable (other than the exceptional case referred to in Article 3, Paragraph 1) licensed to use the Licensed Software within the country of the User (the country where the User bought the Product (hereinafter the “Country”).

#### Article 2 License

- The license granted under this Agreement shall be the right to use the Licensed Software in the Product.
- The User shall not duplicate, copy, modify, add, translate or otherwise alter, or lease the Licensed Software and any related documents, whether in whole or in part.
- The use of the Licensed Software shall be limited to personal purpose, and the Licensed Software shall not be distributed, licensed or sub-licensed whether it is for commercial purpose or not.
- The User shall use the Licensed Software according to the directions described in the operation manual or help file, and is prohibited to use or duplicate any data in a manner violating the Copyright Law or any other laws and regulations by applying whole or a part of the Licensed Software.

#### Article 3 Conditions for Grant of License

- When the User transfers the Product, it may also transfer the license to use the Licensed Software embedded in the Product (including any related materials, updates and upgrades) on condition that no original, copies or related materials continue in the possession of the User, and that the User shall cause the transferee to comply with this Software License Agreement.
- The User shall not carry out reverse engineering, disassembling, decompiling or any other code analysis works in connection with the Licensed Software.

#### Article 4 Right pertaining to the Licensed Software

- Any and all copyrights and other rights pertaining to the Licensed Software and related documents shall belong to the Licensor or the original holder of the right who granted to the Licensor the license or sublicense for the Licensed Software (hereinafter the “Original Rightholder”), and the User shall not be entitled to any right other than the license granted hereunder, in respect of the Licensed Software and any related documents.
- The User shall, whenever the User uses the Licensed Software, comply with any laws relating to the copyright and other intellectual property rights.

#### Article 5 Indemnification of Licensor

- Neither the Licensor nor the Original Rightholder shall be liable for any damage incurred by the User or any third party due to the exercise of the license granted to the User under this Agreement, unless otherwise restricted by law.
- The Licensor will offer no guarantee for the merchantability, convertibility and consistency with certain objective of the Licensed Software.

#### Article 6 Liability to Third Party

If any dispute has arisen with any third party due to an infringement upon a copyright, patent or any other intellectual property right that was caused by the User’s use of the Licensed Software, the User shall settle such dispute at the User’s own cost and hold the Licensor and the Original Rightholder harmless from any inconvenience it may cause.

#### Article 7 Confidentiality

The User shall keep the confidentiality of such portion of the Licensed Software, related documents thereof or any other information to be granted under this Agreement, as well as the conditions of this Agreement as has not yet entered the public domain, and shall not disclose or divulge the same to any third party without approval of the Licensor.

#### Article 8 Termination

In case the User falls under any of the events described in the following items, the Licensor may immediately terminate this Agreement or claim that the User compensates for the damage incurred by the Licensor due to such event:

(1) when the User violated any provision of this Agreement; or
(2) when a petition has been filed against the User for an attachment, provisional attachment, provisional disposition or any other compulsory execution.

#### Article 9 Destruction of the Licensed Software

If this Agreement is terminated pursuant to the provision of Article 8, the User shall destroy the Licensed Software, any related documents and copies thereof within two (2) weeks from such date of termination.

#### Article 10 Export Restriction

- The User shall understand that the Licensed Software shall be subject to the export restrictions adopted by the country of User and any other countries.
- The User shall agree that the software will be subject to any and all applicable international and domestic laws including the export control regulation of the country of User and any other countries, and any restrictions concerning the end-users, the use by end-users and importing countries to be provided by the country of User and any other countries, and any other governmental authorities.
- If the User is an agency of the United States of America (the “Government”), the User acknowledge Licensor’s representation that the Licensed Software is a “Commercial Item” as defined in Federal Acquisition Regulation (FAR) part 2.101(g) consisting unpublished “Commercial Computer Software” as those items are used at FAR part 12.212 and is only license the User with the same use right Licensor grants all commercial end users pursuant to the terms of this Agreement.

#### Article 11 Miscellaneous

- In the event any part of this Agreement is invalidated by operation of law, the residual provisions shall continue in force.
- Matters not stipulated in this Agreement or any ambiguity or question raised in the construction of this Agreement shall be provided or settled upon good-faith consultation between the Licensor and the User.
- The Licensor and the User hereby agree that this Agreement is governed by the laws of Japan, and any dispute arising from, and relating to the rights and obligations under, this Agreement shall be submitted to the exclusive jurisdiction of the Tokyo District Court for its first instance.

© 2020 JVCKENWOOD Corporation

B5A-3431-10