

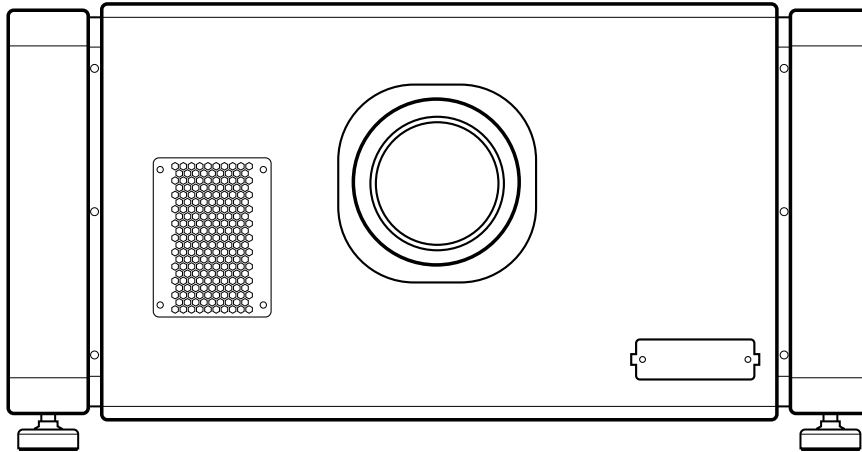

D-LIA[®] PROJECTOR

DLA-SH7NL

INSTRUCTIONS



(Lens is optional)

Thank you for purchasing this JVC product.

Please study this instruction manual carefully before starting to operate the unit, in order to use the unit correctly. We take no responsibility for any problems resulting from misuse of this unit by operating this equipment other than instructed in this manual.

For Customer use :

Enter below the serial No. which is located on the bottom side of the cabinet. Retain this information for future reference.

Model No. DLA-SH7NL

Serial No. _____

Getting Started

Connection and Installation

Network Settings

Operation and Settings

Others

Safety Precautions

IMPORTANT INFORMATION

This product has a High Intensity Discharge (HID) lamp that contains mercury.

Disposal of these materials may be regulated in your community due to environmental considerations. For disposal or recycling information, please contact your local authorities or for USA, the Electronic Industries Alliance: <http://www.eiae.org>.

WARNING:

TO PREVENT FIRE OR SHOCK HAZARDS, DO NOT EXPOSE THIS APPLIANCE TO RAIN OR MOISTURE.

WARNING:

THIS APPARATUS MUST BE EARTHED.

CAUTION:

To reduce the risk of electric shock, do not remove cover. Refer servicing to qualified service personnel.

This projector is equipped with a 3-blade grounding type plug to satisfy FCC rule. If you are unable to insert the plug into the outlet, contact your electrician.

FCC INFORMATION (U.S.A. only)

CAUTION:

Changes or modification not approved by JVC could void the user's authority to operate the equipment.

NOTE:

This equipment has been tested and found to comply with the limits for a Class A digital device, pursuant to Part 15 of the FCC Rules. These limits are designed to provide reasonable protection against harmful interference when the equipment is operated in a commercial environment. This equipment generates, uses, and can radiate radio frequency energy and, if not installed and used in accordance with the instruction manual, may cause harmful interference to radio communications. Operation of this equipment in a residential area is likely to cause harmful interference in which case the user will be required to correct the interference at his own expense.

MACHINE NOISE INFORMATION (Germany only)

Changes Machine Noise Information Ordinance 3. GSGV, January 18, 1991: The sound pressure level at the operator position is equal or less than 70 dB (A) according to ISO 7779.

About the installation place

Do not install the projector in a place that cannot support its weight securely.

If the installation place is not sturdy enough, the projector could fall or overturn, possibly causing personal injury.

IMPORTANT SAFEGUARDS

Electrical energy can perform many useful functions. This unit has been engineered and manufactured to assure your personal safety. But IMPROPER USE CAN RESULT IN POTENTIAL ELECTRICAL SHOCK OR FIRE HAZARD. In order not to defeat the safeguards incorporated into this product, observe the following basic rules for its installation, use and service. Please read these Important Safeguards carefully before use.

- All the safety and operating instructions should be read before the product is operated.
- The safety and operating instructions should be retained for future reference.
- All warnings on the product and in the operating instructions should be adhered to.
- All operating instructions should be followed.
- Place the projector near a wall outlet where the plug can be easily unplugged.
- Unplug this product from the wall outlet before cleaning. Do not use liquid cleaners or aerosol cleaners. Use a damp cloth for cleaning.
- Do not use attachments not recommended by the product manufacturer as they may be hazardous.
- Do not use this product near water. Do not use immediately after moving from a low temperature to high temperature, as this causes condensation, which may result in fire, electric shock, or other hazards.
- Do not place this product on an unstable cart, stand, or table. The product may fall, causing serious injury to a child or adult, and serious damage to the product. The product should be mounted according to the manufacturer's instructions, and should use a mount recommended by the manufacturer.
- When the product is used on a cart, care should be taken to avoid quick stops, excessive force, and uneven surfaces which may cause the product and cart to overturn, damaging equipment or causing possible injury to the operator.

PORTABLE CART WARNING (symbol provided by RETAC)



S3126A

- Slots and openings in the cabinet are provided for ventilation. These ensure reliable operation of the product and protect it from overheating. These openings must not be blocked or covered. (The openings should never be blocked by placing the product on bed, sofa, rug, or similar surface. It should not be placed in a built-in installation such as a bookcase or rack unless proper ventilation is provided and the manufacturer's instructions have been adhered to.) For proper ventilation, separate the product from other equipment, which may prevent ventilation and keep a distance (see Page 14).
- This product should be operated only with the type of power source indicated on the label. If you are not sure of the type of power supply to your home, consult your product dealer or local power company.
- This product is equipped with a three-wire plug. This plug will fit only into a grounded power outlet. If you are unable to insert the plug into the outlet, contact your electrician to install the proper outlet. Do not defeat the safety purpose of the grounded plug.
- The lens for this product is optional. Do not attach the power cord when the lens is not attached. Turning on the power when no lens is attached may result in fire, electric shock, or other hazards.
- Power-supply cords should be routed so that they are not likely to be walked on or pinched by items placed upon or against them. Pay particular attention to cords at doors, plugs, receptacles, and the point where they exit from the product.
- For added protection of this product during a lightning storm, or when it is left unattended and unused for long periods of time, unplug it from the wall outlet and disconnect the cable system. This will prevent damage to the product due to lightning and power line surges.
- Do not overload wall outlets, extension cords, or convenience receptacles on other equipment as this can result in a risk of fire or electric shock.
- Never push objects of any kind into this product through openings as they may touch dangerous voltage points or short out parts that could result in a fire or electric shock. Never spill liquid of any kind on the product.
- Do not attempt to service this product yourself as opening or removing covers may expose you to dangerous voltages and other hazards. Refer all service to qualified service personnel.
- Unplug this product from the wall outlet and refer service to qualified service personnel under the following conditions:
 - a) When the power supply cord or plug is damaged.
 - b) If liquid has been spilled, or objects have fallen on the product.
 - c) If the product has been exposed to rain or water.
 - d) If the product does not operate normally by following the operating instructions. Adjust only those controls that are covered by the Operation Manual, as an improper adjustment of controls may result in damage and will often require extensive work by a qualified technician to restore the product to normal operation.
 - e) If the product has been dropped or damaged in any way.
 - f) When the product exhibits a distinct change in performance - this indicates a need for service.
- When replacement parts are required, be sure the service technician has used replacement parts specified by the manufacturer or with same characteristics as the original part. Unauthorized substitutions may result in fire, electric shock, or other hazards.
- Upon completion of any service or repairs to this product, ask the service technician to perform safety checks to determine that the product is in proper operating condition.
- The product should be placed more than one foot away from heat sources such as radiators, heat registers, stoves, and other products (including amplifiers) that produce heat.
- When connecting other products such as VCR's, and DVD players, you should turn off the power of this product for protection against electric shock.
- Do not place combustibles behind the cooling fan. For example, cloth, paper, matches, aerosol cans or gas lighters that present special hazards when over heated.
- Do not look into the projection lens while the illumination lamp is turned on. Exposure of your eyes to the strong light can result in impaired eyesight.
- Do not look into the inside of this unit through vents (ventilation holes), etc. Do not look at the illumination lamp directly by opening the cabinet while the illumination lamp is turned on. The illumination lamp also contains ultraviolet rays and the light is so powerful that your eyesight can be impaired.
- Do not drop, hit, or damage the light-source lamp (lamp unit) in any way. It may cause the light-source lamp to break and lead to injuries. Do not use a damaged light source lamp. If the light-source lamp is broken, ask your dealer to repair it. Fragments from a broken light-source lamp may cause injuries.
- The light-source lamp used in this projector is a high pressure lamp. Be careful when disposing of the lightsource lamp. If anything is unclear, please consult your dealer.
- Do not ceiling-mount the projector to a place which tends to vibrate; otherwise, the attaching fixture of the projector could be broken by the vibration, possibly causing it to fall or overturn, which could lead to personal injury.
- Use only the accessory cord designed for this product to prevent shock.

***DO NOT allow any unqualified person to install the unit.**
 Be sure to ask your dealer to install the unit (e.g. attaching it to the ceiling) since special technical knowledge and skills are required for installation. If installation is performed by an unqualified person, it may cause personal injury or electrical shock.

Safety Precautions (Cont'd)

POWER CONNECTION

For USA and Canada only
Use only the following power cord.

Power cord

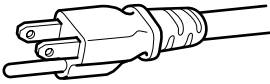

The power supply voltage rating of this product is AC110V – AC240V. Use only the power cord designated by our dealer to ensure Safety and EMC.

Ensure that the power cable used for the projector is the correct type for the AC outlet in your country. Consult your product dealer.

Power cord

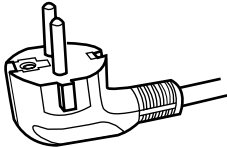

For European continent countries

WARNING:
Do not cut off the main plug from this equipment.

If the plug fitted is not suitable for the power points in your home or the cable is too short to reach a power point, then obtain an appropriate safety approved extension lead or adapter or consult your dealer. If nonetheless the mains plug is cut off, dispose of the plug immediately, to avoid a possible shock hazard by inadvertent connection to the main supply. If a new main plug has to be fitted, then follow the instruction given below.

WARNING:
THIS APPARATUS MUST BE EARTHED.

IMPORTANT:
The wires in the mains lead on this product are colored in accordance with the following cord:
Green-and-yellow : Earth
Blue : Neutral
Brown : Live

As these colors may not correspond with the colored making identifying the terminals in your plug, proceed as follows:
The wire which is colored green-and-yellow must be connected to the terminal which is marked ⊕ with the letter E or the safety earth or colored green or green-and-yellow.
The wire which is colored blue must be connected to the terminal which is marked with the letter N or colored black.
The wire which is colored brown must be connected to the terminal which is marked with the letter L or colored red.

EMC Supplement

- This equipment is in conformity with the provisions and protection requirements of the corresponding European Directives.

This equipment is designed for professional projector appliances and can be used in the following environments.

- Controlled EMC environment (for example purpose built broadcasting or recording studio), and the rural outdoors environment (far away from railways, transmitters, overhead power lines, etc).

In order to keep the best performance and furthermore for electromagnetic compatibility we recommend to use the cables not exceeding the following length:

Cables		Length
Power cord	Power supply cord	3.3 m
DVI (X4) Cable	Shielded cable	5.0 m
USB Cable	Shielded cable	2.0 m
LAN Cable	Shielded cable	2.0 m
RS-232C Cable	Shielded cable	1.6 m

- The inrush current of this apparatus is 11.945 amperes.

WARNING

This equipment is compliant with Class A of CISPR 32.

In residential environment this equipment may cause radio interference.

Dear Customer,

This apparatus is in conformance with the valid European directives and standards regarding electromagnetic compatibility and electrical safety.

European representative of JVC KENWOOD Corporation is:

JVCKENWOOD Deutschland GmbH

Konrad-Adenauer-Allee 1-11

61118 Bad Vilbel

GERMANY

ENGLISH

Information for Users on Disposal of Old Equipment and Batteries

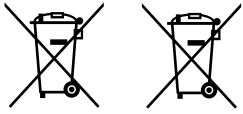

Products

Battery

[European Union only]

These symbols indicate that equipment with these symbols should not be disposed of as general household waste. If you want to dispose of the product or battery, please consider the collection systems or facilities for appropriate recycling.

Notice: The sign Pb below the symbol for batteries indicates that this battery contains lead.

FRANÇAIS

Informations relatives à l'élimination des appareils et des piles usagés, à l'intention des utilisateurs

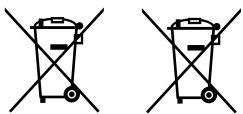

Produits

Pile

[Union européenne seulement]

Si ces symboles figurent sur les produits, cela signifie qu'ils ne doivent pas être jetés comme déchets ménagers. Si vous voulez jeter ce produit ou cette pile, veuillez considérer le système de collecte des déchets ou les centres de recyclage appropriés.

Notification: La symbole Pb en dessous du symbole des piles indique que cette pile contient du plomb.

ESPAÑOL / CASTELLANO

Información para los usuarios sobre la eliminación de baterías/pilas usadas

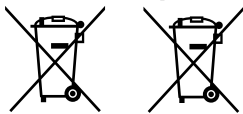

Productos

Baterías/pilas

[Sólo Unión Europea]

Estos símbolos indican que el equipo con estos símbolos no debe desecharse con la basura doméstica. Si desea desechar el producto o batería/pila, acuda a los sistemas o centros de recogida para que los reciclen debidamente.

Atención: La indicación Pb debajo del símbolo de batería/pila indica que ésta contiene plomo.

Benutzerinformationen zur Entsorgung alter Geräte und Batterien

Produkte



Batterie

[Nur Europäische Union]

Diese Symbole zeigen an, dass derartig gekennzeichnete Geräte nicht als normaler Haushaltsabfall entsorgt werden dürfen. Wenden Sie sich zur Entsorgung des Produkts oder der Batterie an die hierfür vorgesehenen Sammelstellen oder Einrichtungen, damit eine fachgerechte Wiederverwertung möglich ist.

Hinweis: Das Zeichen Pb unterhalb des Batteriesymbols gibt an, dass diese Batterie Blei enthält.

Informazioni per gli utenti sullo smaltimento delle apparecchiature e batterie obsolete

Prodotti



Batteria

[Solo per l'Unione Europea]

Questi simboli indicano che le apparecchiature a cui sono relativi non devono essere smaltite tra i rifiuti domestici generici. Se si desidera smaltire questo prodotto o questa batteria, prendere in considerazione i sistemi o le strutture di raccolta appropriati per il riciclaggio corretto.

Nota: Il simbolo Pb sotto il simbolo delle batterie indica che questa batteria contiene piombo.

Informatie voor gebruikers over het verwijderen van oude apparatuur en batterijen

Producten



Batterij

[Alleen Europese Unie]

Deze symbolen geven aan dat apparatuur met dit symbool niet mag worden weggegooid als algemeen huishoudelijk afval. Als u het product of de batterij wilt weggooien, kunt u inzamelsystemen of faciliteiten voor een geschikte recycling gebruiken.

Opmerking: Het teken Pb onder het batterijsymbool geeft aan dat deze batterij lood bevat.

Memo :

Memo :

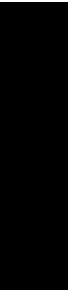

Contents

Getting Started

Safety Precautions 2
 Contents 10
 Accessories 10
 Precautions During Use 11
 Names and Functions of Parts 12

Connection and Installation

Installation 14
 Optional Projection Lens 14
 Minimum Space Required 14
 Projector Installation Angle 15
 Installing the Projector and Screen 15
 Screen Size and Projection Distance 18
 Connecting Video Signals of the Computer 20
 Connection During Single-Screen Mode Display 20
 Connection During Two-Screen/Four-Screen Mode Display 22

Network Settings

Connection Using a LAN Cable 24
 Connection Example 24
 Specifications of PC for Controlling this Projector 24
 Turning On the Main Power 25
 IP Address Settings 26
 Assigning a static IP address 26
 Assigning IP Address from the DHCP Server 29
 Using the Mail Delivery Feature 29
 Connection Example (When DHCP Server is Used) 29

Operation and Settings

Projecting Image 30
 Useful Features During Projection 31
 Displaying the Menu 32
 User Settings Menu 33
 User Settings Menu Structure 33
 (1) Main Menu 34
 (2) Image Menu 37
 (3) Setting Menu 38
 (4) Convergence Menu 39
 (5) Lens Menu 40
 (6) Option Menu 41
 Administrator Settings Menu 43
 Administrator Settings Menu Structure 43
 (7) Admin.Network Menu 44
 (8) Admin.E-mail Menu 46
 (9) Admin.Option Menu 48
 (10) Admin.Signal Menu 49

Others

Troubleshooting 51
 What to do when these messages are displayed 53
 Warnings Using Indicators 54
 Warning Status 55
 RS-232C Interface 56
 Communication Specifications 56
 Command Format 56
 Maintenance 58
 Cleaning and Replacing the Filter 58
 Routine Servicing 59
 Replacement of Light Source Lamp 59
 Specifications 60
 Dimensional Outline Drawing 62
 GNU GENERAL PUBLIC LICENSE
 Version 2, June 1991 63

Accessories

- Power Cord
 For the US market (3.3 m x 1)

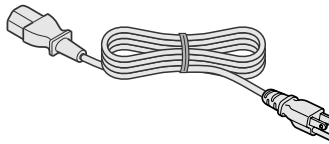

- For the EU market (3.3 m x 1)

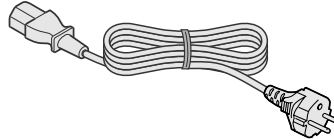

- Plug Holder x1
- Other items include the instruction manual, warranty, and other printed materials.

How to Read this Manual

■ Symbols used in this manual

CAUTION: Describes precautions to note when operating this product.

NOTE : Describes reference information, such as functions and restrictions during use.

 : Indicates the page or section to refer to.

■ Content of this manual

- Personal computers or computers are expressed as computers or PCs in this manual.
- Contents of this manual are the copyright of JVC. All rights reserved. Unauthorized reproduction and duplication of this manual, in whole or in part, without the permission of JVC is strictly prohibited.
- The names of other companies' products that appear in this manual are the trademark or registered trademark of the respective companies. Symbols such as TM, ®, and © are omitted in this manual.
- Designs, specifications, and other details described in this manual may be modified for improvement without prior notice.

Precautions During Use

Burning-in of D-ILA Device

■ **Do not allow the same still picture to be projected for a long time or an abnormally bright video image to be projected**

Do not project still images with a high brightness or high contrast on the screen for a long time. This video image could be burnt into the D-ILA device.

Pay special attention when projecting video games and computer program images.

Motion images such as normal video playback images do not pose the burning-in problem.

Viewing Conditions (Brightness of Room)

■ **Brightness of the room**

Avoid direct exposure of screen to direct sunlight and lights such as by using a curtain. Images can be well projected by darkening the brightness of the room.

■ **Do not view screen for prolonged hours**

Looking at the screen continually for a prolonged time is tiring to the eyes. Allow your eyes to rest at intervals.

■ **Do not use this unit when image flickers**

Image may flicker due to installation conditions and environment. This may cause your eyesight to deteriorate.

Environment of Use

■ **Do not use this projector in rooms with cigarette smoke or oily smoke**

Do not use this projector in rooms with cigarette smoke or oily smoke. This may cause the unit to malfunction.

■ **When mounting this projector to the ceiling**

Check the temperature around the projector unit. When a heater is in use, the ceiling may reach a temperature higher than anticipated, hence leading to malfunction of the unit.

Maintenance Procedures

■ **Clean dirt on the cabinet**

Do this with a soft cloth. In case of heavy soiling, soak a cloth in neutral detergent diluted with water, wring dry and wipe, followed by wiping again using a dry cloth.

■ **Pay attention to the following to prevent the cabinet from deteriorating in condition, getting damaged, or the paint from coming off.**

- Do not wipe with a stiff cloth
- Do not wipe with force
- Do not wipe with thinner or benzene
- Do not spray volatile chemicals like insecticide
- Do not allow prolonged contact with rubber or plastic products

■ **Clean dirt on the lens**

Do this using commercial blowers or lens cleaning papers (for cleaning glasses and cameras). Do not use fluid-type cleaning agents. This may lead to peeling of the surface coating film. Lens surface is fragile. Avoid rubbing it hard or knocking it.

Gauging replacement time of components

This product comes with replacement components required for maintaining the functions of this product, such as optical components, cooling fan and filters. The timing for replacing components varies considerably according to the frequency and environment of use. For details on replacement of components (except filters), please consult your authorized dealer.

Names and Functions of Parts

Front/Right/Rear Side

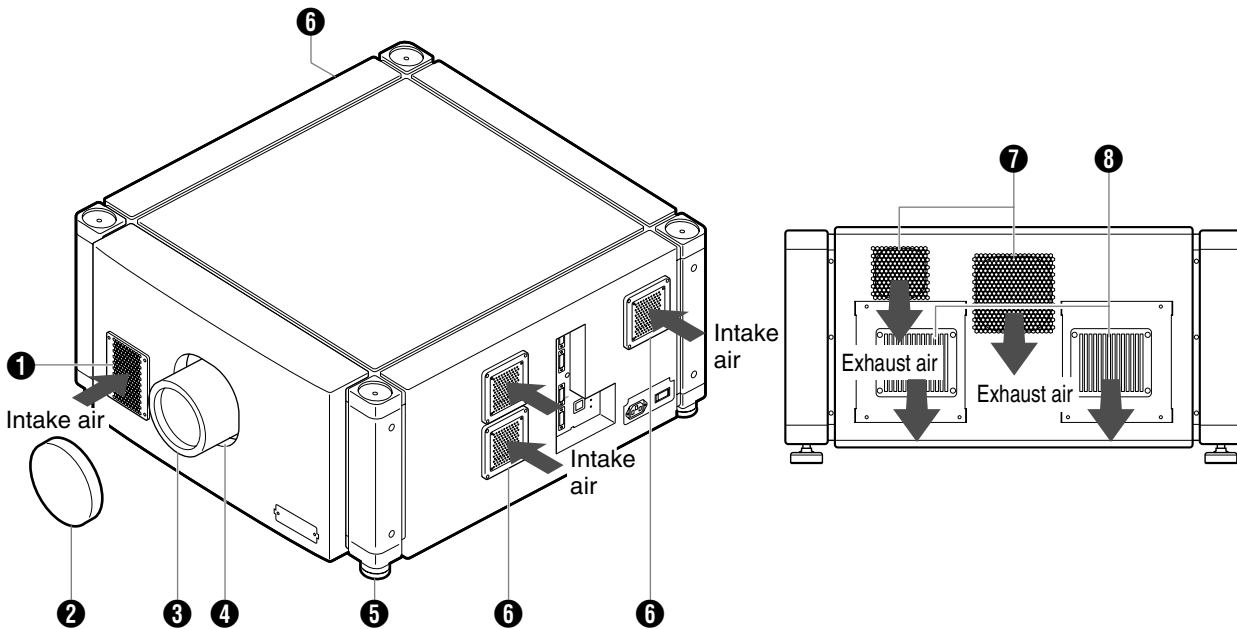

1 Air Inlet/Filter

The air inlets absorb air to cool the interior of the projector. A filter is mounted inside the projector to remove dirt in the air that enters through the inlets. Clean the filter regularly. (☞ Page 58)

CAUTION:

- Do not block the air inlets with papers, cloth, or soft cushions. Doing so may cause heat to trap inside the projector and result in fire or malfunction.

2 Lens Cap (included with the optional lens)

Fit the cap on the lens when this projector is not in use to prevent the lens from becoming dirty.

CAUTION:

- Do not project images with the lens cap attached. The lens cap may be deformed due to the heat, or the projector may malfunction.

3 Projection Lens (optional)

Zoom lens or short focal length lens is optional. (☞ Page 60)
Remove the lens cap before projection.

4 Lens Mounting Bracket

Mount the optional projection lens.

5 Adjustable Feet (x4)

Adjust the feet until the projector is level. The adjustable range is 20 mm for each. (☞ Page 15)

6 Air Inlet/Filter (Right Side: x3, Left Side: x1)

The air inlets absorb air to cool the interior of the projector. A filter is mounted inside the projector to remove dirt in the air that enters through the inlets. Clean the filter regularly. (☞ Page 58)

7 Vent Hole

Warm air exits from the hole after cooling the projector.

CAUTION:

- Do not block the vent holes with papers, cloth, or soft cushions. Doing so may cause heat to trap inside the projector and result in fire or malfunction.

8 Vent Hole

Warm air exits from the hole after cooling the lamp.

Right Side

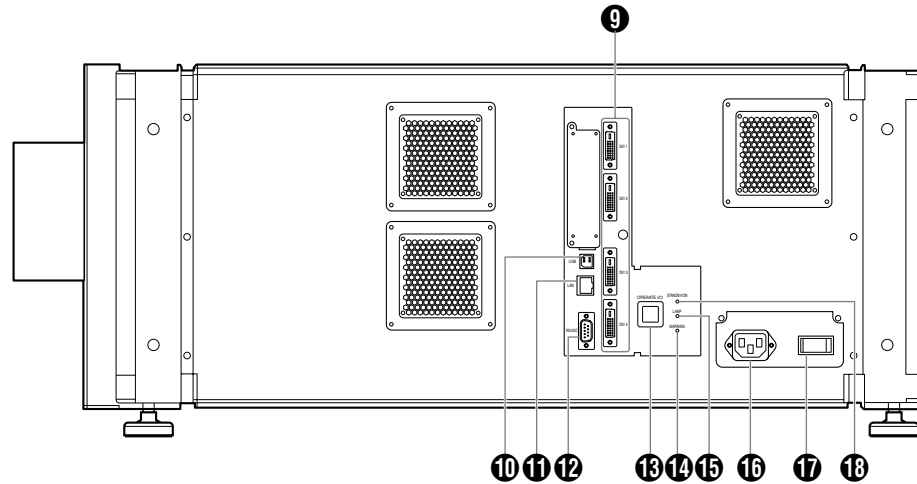

9 [DVI 1 to 4] Terminal

This is an input terminal for video signals. Connect it to the video output terminal of the computer.
(☞ Page 21, 23)

10 [USB] Terminal

Enables control of this projector by connecting it to a computer.

11 [LAN] Terminal

Enables control of this projector using a computer that is connected to the network.

12 [RS-232C] Terminal

This is the RS-232C interface-specific terminal. This projector can be controlled by connecting it to a computer using a RS-232C cable.

13 [OPERATE I/ON] Button

Pressing this button for one second or longer when in the standby mode (main power supply is ON) turns on the power of the projector unit. Pressing it for one second or longer when the power is ON switches the projector to the standby mode.

14 [WARNING] Indicator

This indicator lights up in red when abnormality occurs on this projector. For details, refer to “Warnings Using Indicators”. (☞ Page 54)

15 [LAMP] Indicator

This indicator lights up in yellow when the lamp time exceeds 1900 hours.

NOTE:

- For details on indicator displays during warnings, refer to “Warnings Using Indicators”. (☞ Page 54)
- A lamp life message appears when the lamp time has exceeded 2000 hours.
(☞ Page 53)

16 AC Power Input Terminal

Connect the supplied cord to this terminal.



17 Main Power Supply Switch

Use this to turn ON/OFF the main power supply of the projector unit.

18 [STANDBY/ON] Indicator

- Lit (Red) : When in the standby mode.
- Lit (Green) : When power is supplied.
- Blinking (Red) : When cooling down (cool down mode).
(☞ Page 31)
- Blinking (Green) : When the projected image is temporarily hidden. (☞ Page 31)

NOTE:

- For details on indicator displays during warnings, refer to “Warnings Using Indicators”. (☞ Page 54)
- A stand-BY condition is indicated by the symbol .
- Power ON condition is indicated by the symbol .
- Power OFF condition is indicated by the symbol .

Installation

Please read the following carefully when installing this unit.

Optional Projection Lens

Mount the optional projection lens (☞ Page 60). For details on mounting the lens, please consult your authorized dealer.

Minimum Space Required

Do not use a cover that may enclose this unit or block the air inlets/vent holes. Allow sufficient space around this unit. When this unit is enclosed in a space with dimensions as indicated below, ventilate accordingly so that the internal and external temperatures are the same.

■ When using one set of projector

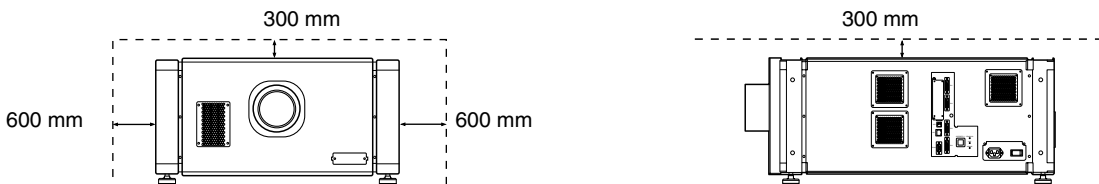

■ When using two sets of projectors side by side

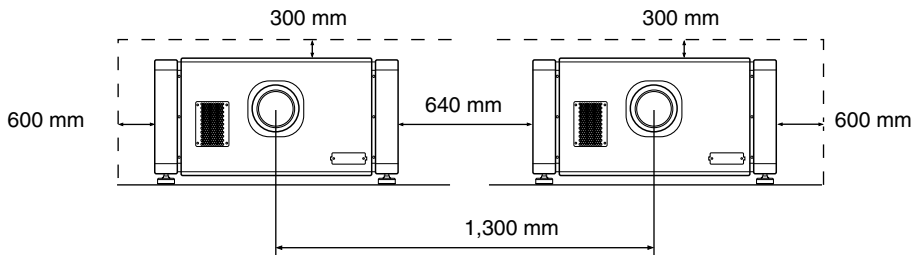

■ When the projector is suspended

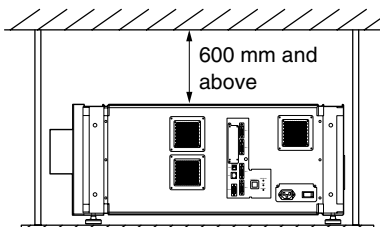

NOTE:

- To prevent the projector from falling or toppling, it is recommended that the holder be fastened to the unit using bolts.
- To mount the projector to the ceiling, mount a special shelf to the ceiling, followed by installing the unit on the shelf. For safety and maintenance purposes, equipment that eases adjustment to a suitable height for maintenance is required.

CAUTION:

- Special expertise and techniques are required for mounting this unit. Be sure to ask your dealer or a specialist to perform mounting.

Projector Installation Angle

You can install this projector between $\pm 90^\circ$. Images will be properly displayed if the horizontal angle is between the range of $\pm 5^\circ$.

However, you have to configure using [Installation Style] (Page 48) for certain installation orientations.

- A: Upward installation (+45° to +90°)
- B: Horizontal installation (-45° to +45°)
- C: Downward installation (-45° to -90°)

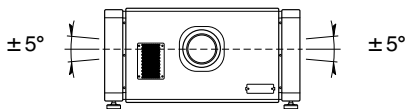
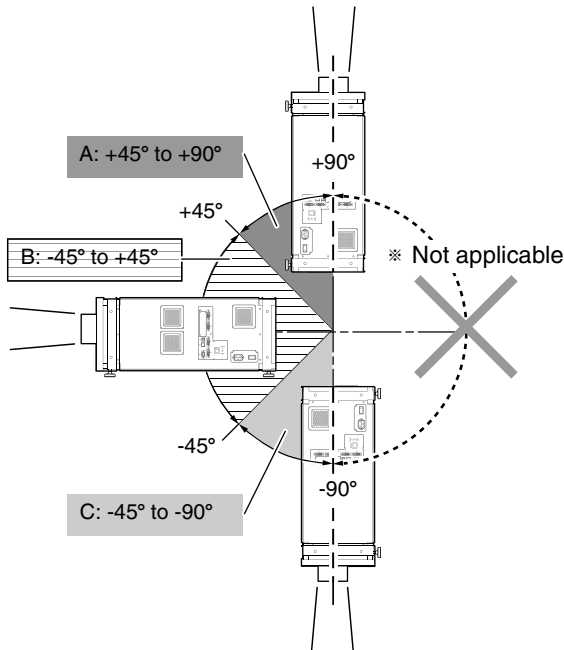

CAUTION:

- To ceiling-mount this unit, special expertise and skills are necessary. Make sure to request the authorized dealer or specialized work contractors for installation.
- The projector cannot be installed upside down.

Adjusting the Inclination

Adjust the horizontal angle of the projector. Lift the projector and turn the nut of the adjustable foot with a spanner in the direction indicated by the arrow to extend or retract the foot. The adjustable range is 20 mm.

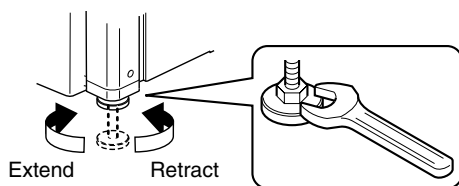

Installing the Projector and Screen

It is recommended that this projector be installed at right angle to the screen.

When a zoom lens (optional) is in use, you can make use of the lens shift feature of this projector to shift the projection screen vertically between 0% to $\pm 50\%$, and horizontally between 0% to $\pm 25\%$.

When a short focal length lens (optional) is in use, you can shift the projection screen position vertically between 0% to $\pm 15\%$, and horizontally between 0% to $\pm 5\%$. Below are some examples on the layout when a zoom lens is used.

When shift amount in the upward direction is +50 %

Install the projector such that the lower end of the projection screen is at the same height as the center of the lens.

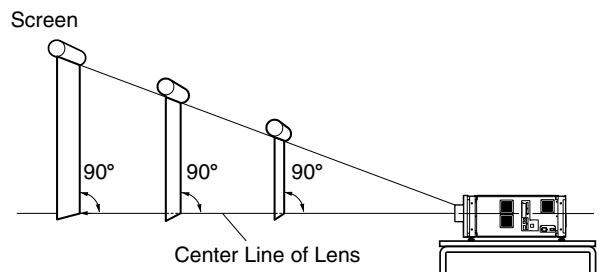

When shift amount in the upward/downward direction is 0 %

Install the projector such that the center of the projection screen is at the same height as the center of the lens.

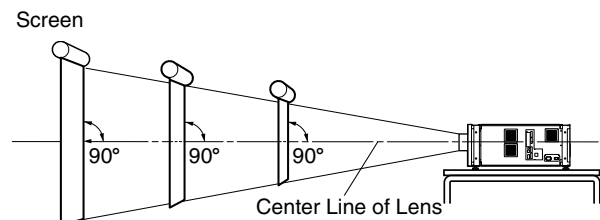

When shift amount in the downward direction is -50 %

Install the projector such that the upper end of the projection screen is at the same height as the center of the lens.

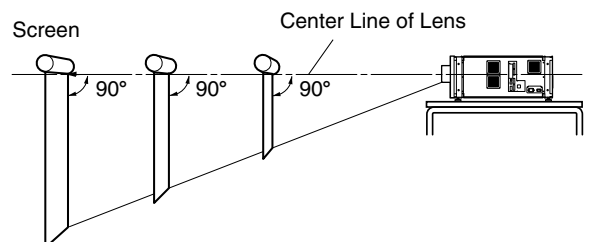

Installing the Projector and Screen (Cont'd)

■ When shift amount in the right direction is +25 %

Install the projector such that the center of the lens is aligned with the 1/4 position from the left edge of the screen.

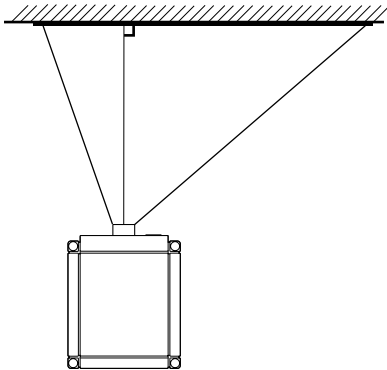

■ When shift amount in the left/right direction is 0 %

Install the projector such that the center of the lens is aligned with the center of the screen.

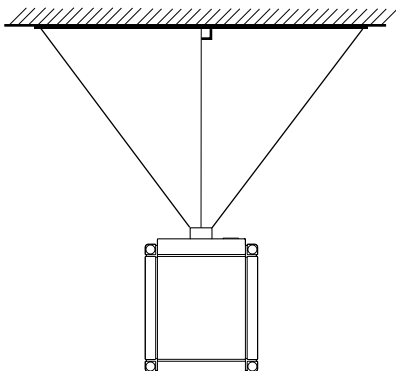

■ When shift amount in the left direction is -25 %

Install the projector such that the center of the lens is aligned with the 1/4 position from the right edge of the screen.

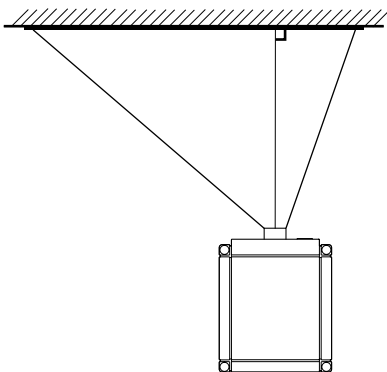

■ Movable Range of Projected Image

- GL-MS4015SZG Zoom lens
- GL-MS4016SZG Zoom lens
- GL-MS4021SZG Zoom lens

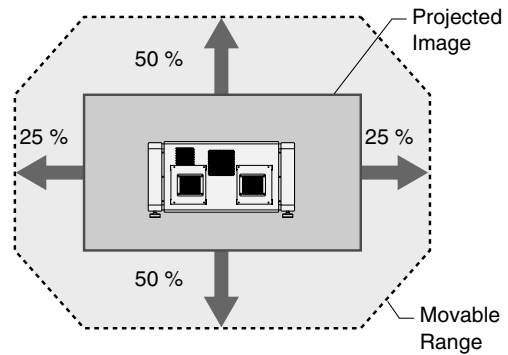

● GL-MS4011SG Short focal length lens

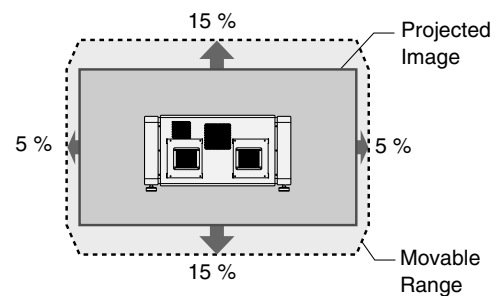

NOTE:

- When using the lens shift feature, do not exceed the range (shift amount) as shown above. If the shift amount exceeds the range as shown, shadows will appear on the projected image.

Lens Fixation Mechanism

A screw for securing the lens mechanism is attached in the factory shipment to prevent damage of the equipment during transportation. If the lens does not move horizontally or vertically when you operate "Shift" in the Lens menu, this could be because the screw has not been removed. When this occurs, please consult your authorized dealer.

■ **Overlaying projected images (when zoom lens is in use)**

● **Projecting images by stacking projectors**

The lens shift feature enables you to use up to three stacked projectors at the same time. Stacking the projectors enhances the brightness level, and helps to project images that are sufficiently bright even when the venue is relatively big or bright.

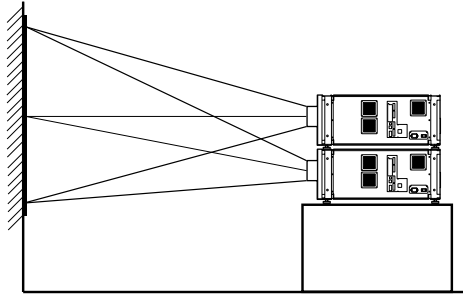

CAUTION: _____

- When the projectors are stacked together during use, ensure that the installation site is sufficiently strong and there is proper air cooling around the projectors. Take the necessary measures to prevent the projectors from toppling or falling off so as to ensure safety during emergency situations, such as earthquakes, and to prevent accidents from occurring. For details, please consult your authorized dealer.

● **Projecting images by arranging projectors side by side**

The lens shift feature enables you to use up to two projectors that are arranged side by side. Arranging two projectors side by side enhances the brightness level, and helps to project images that are sufficiently bright even when the venue is relatively big or bright.

When projecting images by arranging the projectors side by side, adjust the shift amount of both projectors accordingly to superimpose the images.

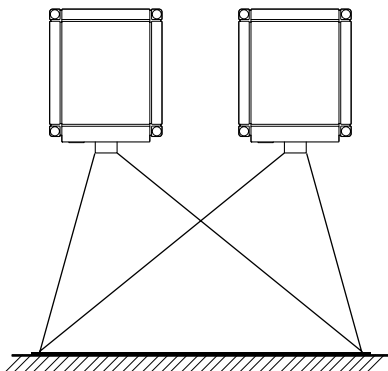

CAUTION: _____

- When using the projectors by arranging them side by side, ensure that the installation site is sufficiently strong and there is proper air cooling around the projectors. For details, please consult your authorized dealer.

■ **When light passes through the glass of projection booth**

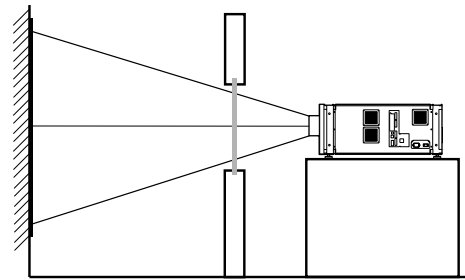

NOTE: _____

- When light passes through the glass, the quantity of light decreases. Make sure that the glass of the projection booth is not more than one piece.
- Do not use glass if possible.
- When projecting light on an inclined glass surface, adjust the glass angle as well as installation angle of this unit accordingly to prevent impact on the image due to diffuse reflection.

Installing the Projector and Screen (Cont'd)

Screen Size and Projection Distance

Adjust the distance from the lens to the screen to achieve your desired screen size.

■ GL-MS4015SZG/GL-MS4016SZG/GL-MS4021SZG Zoom lens

Projection Screen Size (Diagonal Length)	Image Width	Projection distance					
		GL-MS4015SZG		GL-MS4016SZG		GL-MS4021SZG	
		Tele End	Wide End	Tele End	Wide End	Tele End	Wide End
50" (Approx. 1.27 m)	1.10 m	—	—	1.97 m	1.58 m	—	—
60" (Approx. 1.53 m)	1.31 m	—	—	2.37 m	1.92 m	—	—
70" (Approx. 1.79 m)	1.54 m	—	—	2.78 m	2.25 m	—	—
80" (Approx. 2.03 m)	1.75 m	3.19 m	2.58 m	3.19 m	2.58 m	6.38 m	3.72 m
90" (Approx. 2.29 m)	1.97 m	3.60 m	2.91 m	3.60 m	2.91 m	7.19 m	4.24 m
100" (Approx. 2.54 m)	2.19 m	4.01 m	3.25 m	4.01 m	3.25 m	8.01 m	4.71 m
110" (Approx. 2.79 m)	2.41 m	4.42 m	3.58 m	4.42 m	3.58 m	8.82 m	5.17 m
120" (Approx. 3.05 m)	2.63 m	4.83 m	3.91 m	4.83 m	3.91 m	9.63 m	5.64 m
130" (Approx. 3.30 m)	2.85 m	5.24 m	4.25 m	5.24 m	4.25 m	10.44 m	6.11 m
140" (Approx. 3.56 m)	3.07 m	5.65 m	4.58 m	5.65 m	4.58 m	11.25 m	6.57 m
150" (Approx. 3.81 m)	3.29 m	6.06 m	4.91 m	6.06 m	4.91 m	12.06 m	7.04 m
160" (Approx. 4.06 m)	3.51 m	6.46 m	5.25 m	6.46 m	5.25 m	12.87 m	7.50 m
170" (Approx. 4.32 m)	3.73 m	6.87 m	5.58 m	6.87 m	5.58 m	13.68 m	7.97 m
180" (Approx. 4.57 m)	3.94 m	7.28 m	5.91 m	—	5.91 m	14.49 m	8.44 m
190" (Approx. 4.83 m)	4.16 m	7.69 m	6.24 m	—	6.24 m	15.30 m	8.90 m
200" (Approx. 5.08 m)	4.38 m	8.10 m	6.58 m	—	6.58 m	16.12 m	9.44 m
210" (Approx. 5.33 m)	4.60 m	8.51 m	6.91 m	—	6.91 m	16.93 m	9.83 m
220" (Approx. 5.59 m)	4.82 m	8.92 m	7.24 m	—	—	17.74 m	10.30 m
230" (Approx. 5.84 m)	5.04 m	9.33 m	7.58 m	—	—	18.55 m	10.77 m
240" (Approx. 6.10 m)	5.26 m	9.74 m	7.91 m	—	—	19.36 m	11.23 m
250" (Approx. 6.35 m)	5.48 m	10.15 m	8.24 m	—	—	20.17 m	11.70 m
260" (Approx. 6.60 m)	5.70 m	10.55 m	8.58 m	—	—	20.98 m	12.16 m
270" (Approx. 6.86 m)	5.92 m	10.96 m	8.91 m	—	—	21.79 m	12.63 m
280" (Approx. 7.11 m)	6.14 m	11.37 m	9.24 m	—	—	22.60 m	13.10 m
290" (Approx. 7.37 m)	6.36 m	11.78 m	9.57 m	—	—	23.41 m	13.56 m
300" (Approx. 7.62 m)	6.57 m	12.19 m	9.91 m	—	—	24.23 m	14.03 m

NOTE:

- The distance indicated in the table is an estimated value when an image with a resolution of 4096 × 2400 is projected. Please use them as reference during installation.

■ GL-MS4011SG Short focal length lens

Projection Screen Size (Diagonal Length)	Image Width	Projection distance
50" (Approx. 1.27 m)	1.10 m	1.16 m
60" (Approx. 1.52 m)	1.31 m	1.41 m
70" (Approx. 1.78 m)	1.53 m	1.66 m
80" (Approx. 2.03 m)	1.75 m	1.91 m
90" (Approx. 2.29 m)	1.97 m	2.16 m
100" (Approx. 2.54 m)	2.19 m	2.41 m
110" (Approx. 2.79 m)	2.41 m	2.66 m
120" (Approx. 3.05 m)	2.63 m	2.91 m
130" (Approx. 3.30 m)	2.85 m	3.17 m
140" (Approx. 3.56 m)	3.07 m	3.42 m
150" (Approx. 3.81 m)	3.29 m	3.67 m
160" (Approx. 4.06 m)	3.51 m	3.92 m
170" (Approx. 4.32 m)	3.73 m	4.17 m
180" (Approx. 4.57 m)	3.94 m	4.42 m
190" (Approx. 4.83 m)	4.16 m	4.67 m
200" (Approx. 5.08 m)	4.38 m	4.92 m
210" (Approx. 5.33 m)	4.60 m	5.17 m
220" (Approx. 5.59 m)	4.82 m	5.43 m
230" (Approx. 5.84 m)	5.04 m	5.68 m
240" (Approx. 6.10 m)	5.26 m	5.93 m
250" (Approx. 6.35 m)	5.48 m	6.18 m

NOTE:

- The distance indicated in the table is an estimated value when an image with a resolution of 4096 × 2400 is projected. Please use them as reference during installation.

Connecting Video Signals of the Computer

Connection During Single-Screen Mode Display

The single-screen mode displays signals (up to four signals) from a computer as a single video image. To select to the single-screen mode, set “Display Mode” in the Setting menu to “Single”. (☞ Page 38)

■ Possible Input Signals and Projected Image

Computer			Projector Terminal for Connection	Output Status		Displayed Projector Image
Resolution	Channel	Link Status				
4096 × 2400	2ch	Dual	DVI 1, DVI 3	2 Stripes	2048 × 2400	4096 × 2400
	4ch	Single	DVI 1 to DVI 4	Cross	2048 × 1200	
				4 Stripes	1024 × 2400	
4096 × 2160	2ch	Dual	DVI 1, DVI 3	2 Stripes	2048 × 2160	4096 × 2160
	4ch	Single	DVI 1 to DVI 4	Cross	2040 × 1080	
				4 Stripes	1024 × 2160	
3840 × 2400	2ch	Dual	DVI 1, DVI 3	2 Stripes	1920 × 2400	3840 × 2400
	4ch	Single	DVI 1 to DVI 4	Cross	1920 × 1200	
				4 Stripes	960 × 2400	
3840 × 2160	2ch	Dual	DVI 1, DVI 3	2 Stripes	1920 × 2160	3840 × 2160
	4ch	Single	DVI 1 to DVI 4	Cross	1920 × 1080	
				4 Stripes	960 × 2160	
2048 × 1200	1ch	Single	DVI 1	Normal	2048 × 1200	4096 × 2400
2048 × 1080	1ch	Single	DVI 1	Normal	2048 × 1080	4096 × 2160
1920 × 1200	1ch	Single	DVI 1	Normal	1920 × 1200	3840 × 2400
1920 × 1080	1ch	Single	DVI 1	Normal	1920 × 1080	3840 × 2160
1600 × 1200	1ch	Single	DVI 1	Normal	1600 × 1200	3200 × 2400
1280 × 1024	1ch	Single	DVI 1	Normal	1280 × 1024	2560 × 2048
1024 × 768	1ch	Single	DVI 1	Normal	1024 × 768	2048 × 1536
800 × 600	1ch	Single	DVI 1	Normal	800 × 600	1600 × 1200
640 × 480	1ch	Single	DVI 1	Normal	640 × 480	1280 × 960

NOTE:

- This projector converts the frame rate to 60 Hz regardless of the synchronizing signal frequency at the computer's end.
- If the resolution of the PC is 2048 × 1200 or lower, images are displayed upon doubling the number of the vertical and horizontal pixels.

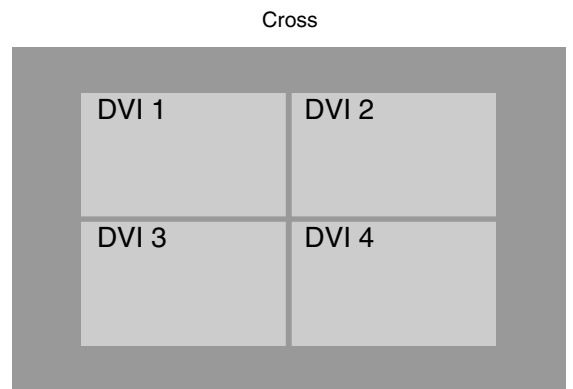
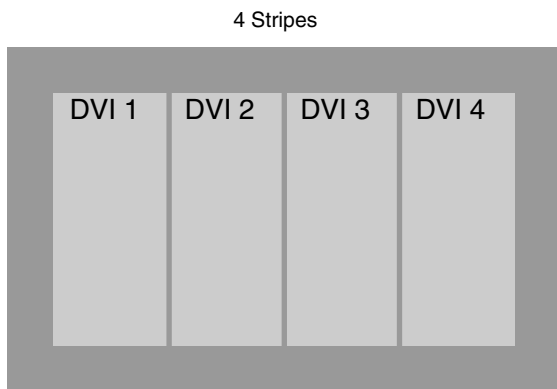
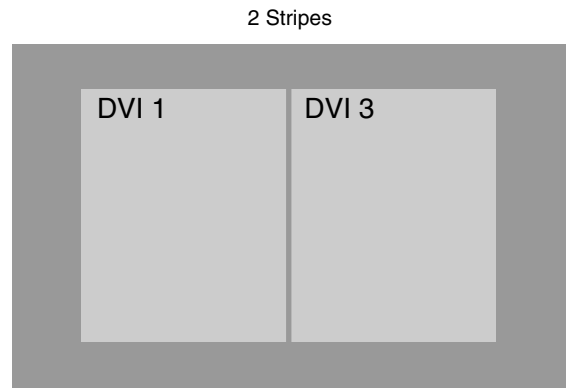
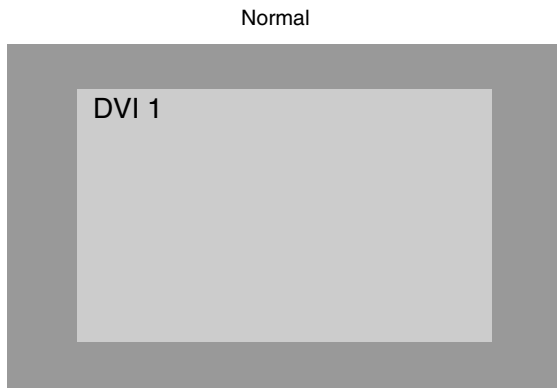

■ Connection During Single-Screen Mode Display

Below is the connection example for four-channel signals from the computer.

For two-channel signals from the computer, connect to the [DVI 1] and [DVI 3] terminals of this projector.

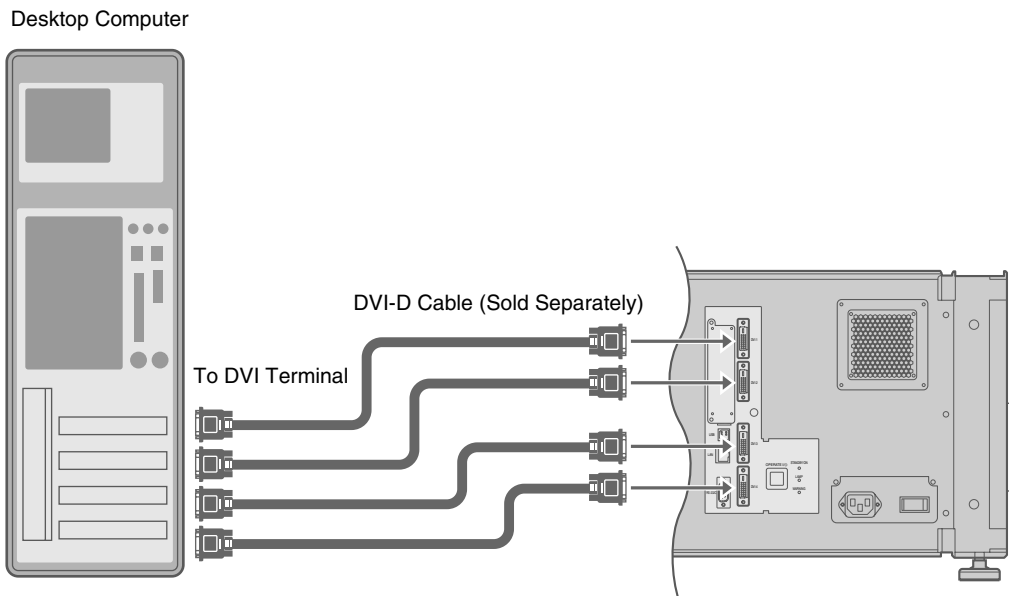

NOTE:

- Depending on your DVI-D cable, the signal may attenuate and the image become unstable.
- Use of DVI-D cables compliant with the DDWG standard is recommended.

Connecting Video Signals of the Computer (Cont'd)

Connection During Two-Screen/ Four-Screen Mode Display

The two-screen/four-screen mode enables simultaneous display of signals from two or four computers. To select the two-screen mode, set "Display Mode" in the Setting menu to "Double". To select the four-screen mode, set "Display Mode" to "Cross". (Page 38)

Possible Input Signals and Projected Image

Computer 1, Computer 2			Output Status	
Resolution	Channel	Link Status		
2048 × 1200	1ch	Single	Normal	2048 × 1200
2048 × 1080	1ch	Single	Normal	2048 × 1080
1920 × 1200	1ch	Single	Normal	1920 × 1200
1920 × 1080	1ch	Single	Normal	1920 × 1080
1600 × 1200	1ch	Single	Normal	1600 × 1200
1280 × 1024	1ch	Single	Normal	1280 × 1024
1024 × 768	1ch	Single	Normal	1024 × 768
800 × 600	1ch	Single	Normal	800 × 600
640 × 480	1ch	Single	Normal	640 × 480

NOTE:

- This projector converts the frame rate to 60 Hz regardless of the synchronizing signal frequency at the computer's end.
- The respective signals are displayed at the center of the split screen.
- When in the two-screen mode, the screen appears blue (or black depending on the setting) when there is no input.

Two-Screen Mode
(Example) DVI 1: 1920 × 1080,
DVI 3: 1920 × 1080

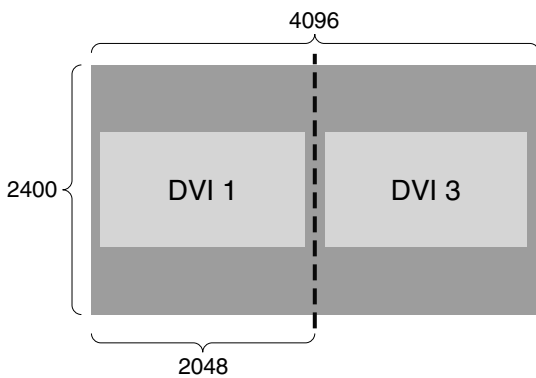

Four-Screen Mode
(Example) DVI 1: 2048 × 1200, DVI 2: 1920 × 1080,
DVI 3: 1024 × 768, DVI 4: 1600 × 1200

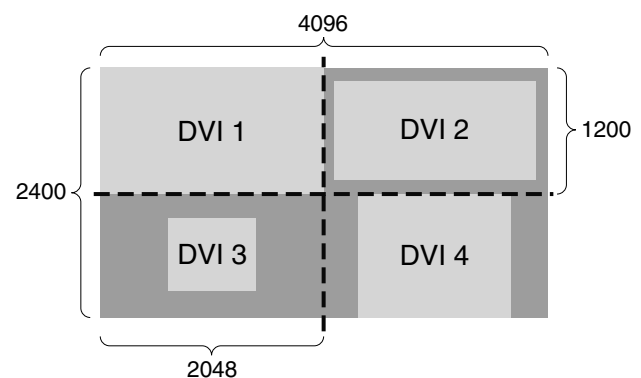

■ Connection Example During Two-Screen Mode

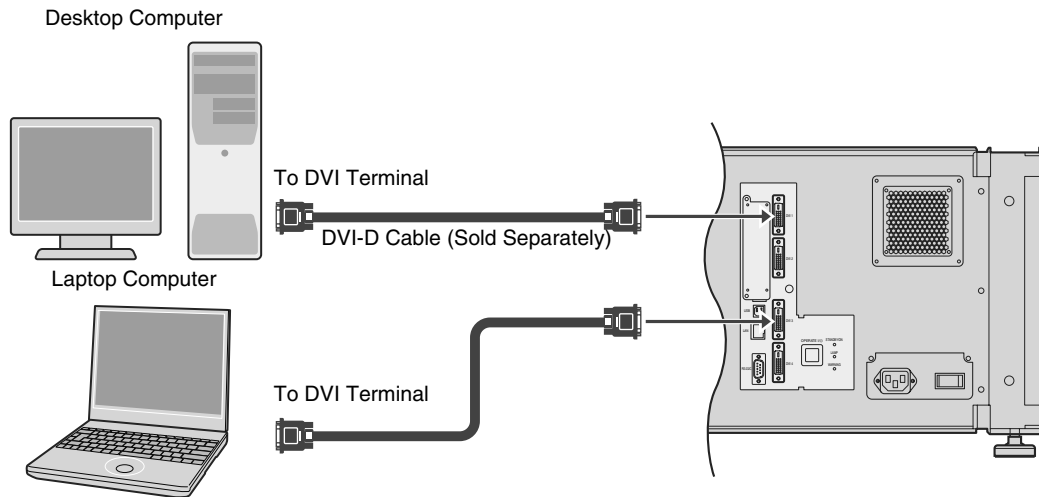

■ Connection Example During Four-Screen Mode

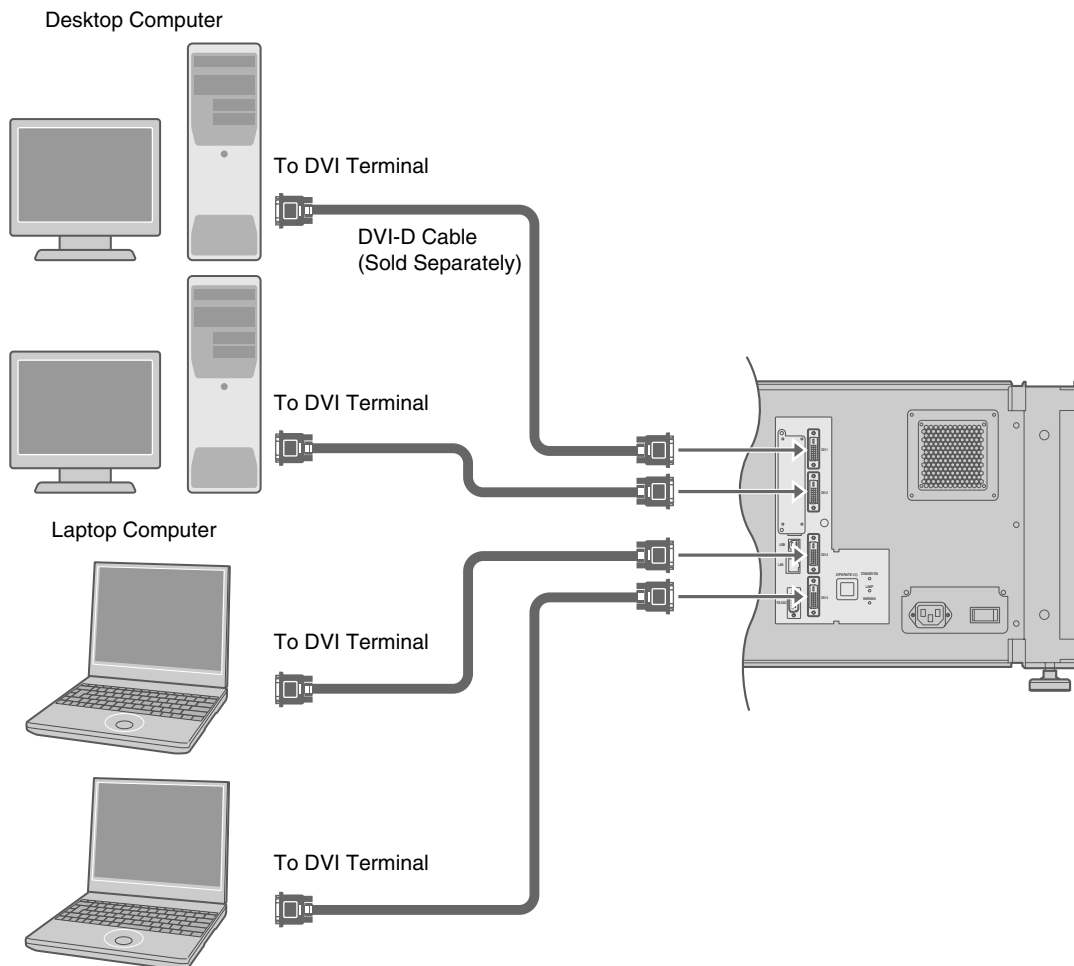

NOTE:

- Depending on your DVI-D cable, the signal may attenuate and the image become unstable.
 - Use of DVI-D cables compliant with the DDWG standard is recommended.
-

Connection Using a LAN Cable

Connect this projector, the computer for controlling this projector, and the switching hub using LAN cables, followed by configuring the network.

Connection Example

■ When assigning a static IP address

You can acquire the IP address from the controlling computer simply by configuring a network that consists of this projector, the controlling computer, and switching hub. Please refer to technical books on networks for details.

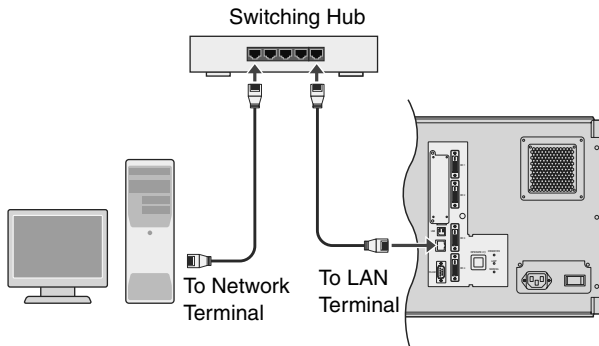

NOTE:

- Make use of Cat. 5 (equivalent or higher) straight 100Base-TX LAN cables.

CAUTION:

- When connecting this projector and the controlling computer for this projector using other network, be sure to consult the network administrator of the network in use or refer to technical books on networks.

■ When assigning IP address from the DHCP server

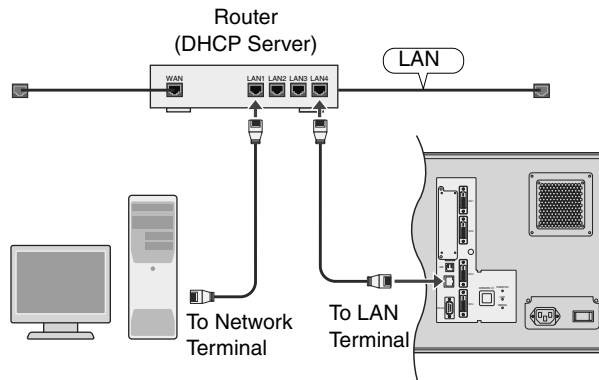

NOTE:

- Make use of Cat. 5 (equivalent or higher) 100Base-TX LAN cables.

Specifications of PC for Controlling this Projector

OS	Windows XP Professional SP2 / Windows XP Home Edition SP2 / Windows 7 Ultimate / Windows 7 Professional / Windows 7 Home Premium
CPU	Pentium3 1 GHz or higher
Memory	256 MB and above

NOTE:

- Make use of Internet Explorer Ver. 6.0 or later.
- Windows® is either registered trademark or trademark of Microsoft Corporation in the United States and/or other countries.

CAUTION:

- The PC specifications above are reference values for the application software to run smoothly, and are not intended to guarantee their operation. Note that the applications may not run smoothly depending on the condition of use of the respective users even when the system requirements are satisfied.

Turning On the Main Power

- 1 Check to ensure that this projector, computer, and switching hub are properly connected
- 2 Connect the power cord to the power input terminal of this projector

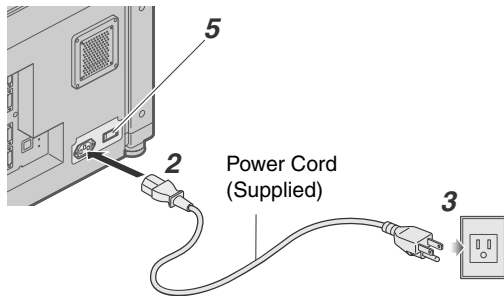

CAUTION:

- Do not connect the power cord when a lens (optional) is not attached.

You can secure the power cord to this projector.

- ① Attach the plug holder to the power cord.
- ② Insert the plug holder into the projector until the upper and lower securing levers are locked.

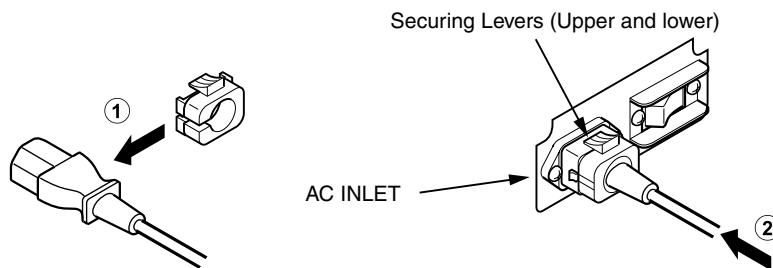

- 3 Insert plug into the power outlet on the wall
- 4 Remove the lens cap
- 5 Turn on the main power of the projector to set to [I]

- The [STANDBY/ON], [LAMP], and [WARNING] indicators light up for about 45 seconds, after which the [STANDBY/ON] indicator turns red.

NOTE:

- The default IP address of all DLA-SH7NL is "192.168.0.2". If multiple units of DLA-SH7NL are used on the same network, do not turn on the main power of more than one projector unit at the same time. Doing so will result in duplication of the IP address, and thereby preventing proper access.
- When using multiple units of DLA-SH7NL, turn on the main power of the second unit and configure accordingly only after configuration of the first unit is complete. Configure subsequent units using the same procedure.
- When duplication occurs in the IP address, make sure that only one unit of DLA-SH7NL is connected on the same network (turn off the main power of the other DLA-SH7NL units). Allow a time interval of at least 10 minutes before accessing. If access fails, turn off the power of all network equipments on the same network, followed by turning them on again.

IP Address Settings

Set the IP address for this projector. There are 2 methods to set the IP address.

- Assigning a static IP address
- Assigning an IP address from the DHCP Server

Assigning a static IP address

The “IP Address Setting” of this projector is set to “STATIC IP” (the DHCP client function is OFF) by default. Upon turning on the power, this projector starts running with the following IP address.

IP Address : 192.168.0.2
Subnet Mask : 255.255.255.0
Default Gateway : 192.168.0.254

IP address setting at the computer

Set the computer to an IP address that enables communication with this projector.

- 1 Click “Start” and select “Control Panel”
- 2 Double click “Network Connections”
- 3 Right-click on “Local Area” and select “Properties”
 - Check to ensure that the “Client for Microsoft Networks” and “Internet Protocol(TCP/IP)” check boxes are selected.
- 4 Select “Internet Protocol(TCP/IP)” and click “Properties”
- 5 Set the IP address

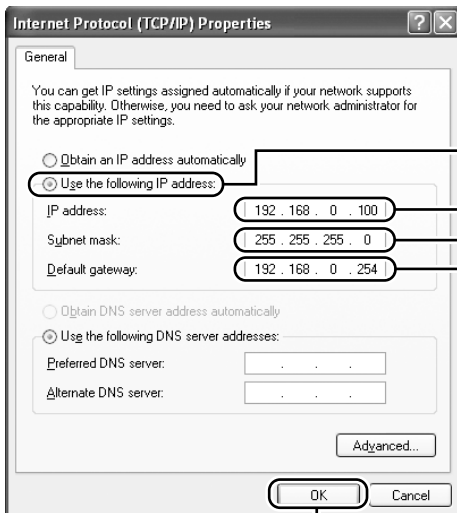

- 1 Select “Use the following IP address”
 - 2 Set “IP address”
(For example, use 192.168.0.100 when DLA-SH7NL is in its default settings)
- NOTE:**
- Make sure that you take note of the original IP address before altering.
 - When setting, ensure that a duplicate IP address is not used within the same network environment.
- 3 Set “Subnet mask”
Set to a value that is appropriate for the setting operation. Clarify with the network administrator if you have any queries. (Use 255.255.255.0 when the camera is in its default settings)
 - 4 When a “Default gateway” is present, make use of the IP address (e.g., 192.168.0.254)
 - 5 Click “OK”

- 6 Click “OK” on the “Local Area Connection Properties” screen

■ Setting (Changing) the IP address of this projector

1 Launch the Internet Explorer on the computer

2 Check if the proxy has been set in the “LAN Setting” of the Internet Explorer

- 1 Click “Tools” and select “Internet Options”
- 2 Click “Connections” and click “LAN Setting”
- 3 Check if the check for “Use a proxy server for your LAN” has been selected
 - If the check mark has been selected, deselect it.

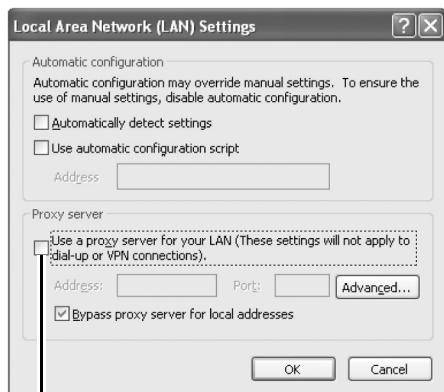

Deselect the check

3 Check if the “Active scripting” of the Internet Explorer is disabled

- 1 Click “Tools” and select “Internet Options”
- 2 Click in the order of “Security”→ “Trusted Sites”→ “Sites”
- 3 Deselect the check “Required server verification (https:) for all sites in this zone”
- 4 Enter “http://192.168.0.2” under “Add this web site to the zone” and click “Add”
- 5 Click “OK”
- 6 Select “Trusted Sites” and click “Custom Level”
- 7 Check if the check for “Active scripting” under “Scripting” has been selected
 - If the check mark has been deselected, select it.

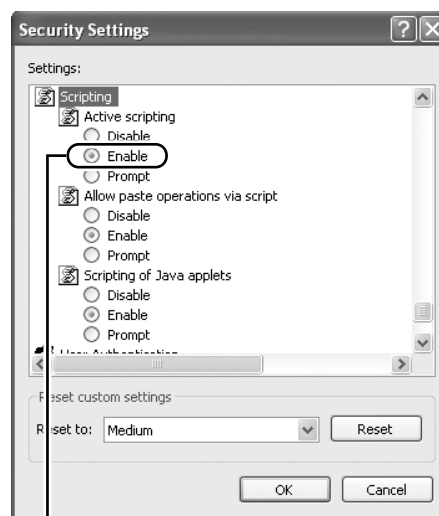

Select “Enable”

IP Address Settings (Cont'd)

Assigning a static IP address (Cont'd)

- 4** Enter "http://192.168.0.2" in the address field of the Internet Explorer, and click "Go"
- A login screen for this projector appears.

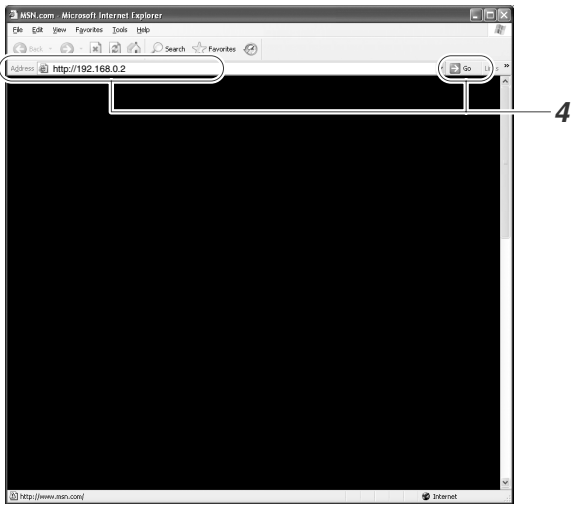

NOTE:

- When "LAN Setting" in Internet Explorer is set to "Use a proxy server for your LAN" it may not be possible to designate addresses directly. Change the proxy settings.
- If a "Security Warning" screen appears, click "OK" and continue.

5 Enter "advanced" in Login Name

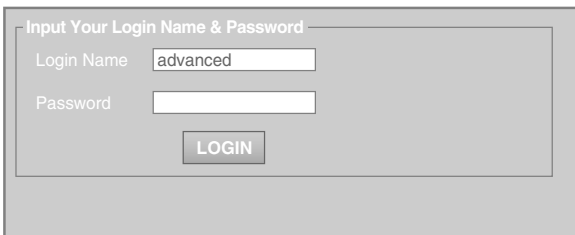

6 Click "LOGIN"

- The main menu for this projector appears.

NOTE:

- You can alter the user name and password in the "Admin.Network" menu. Specify a user name and password of not more than eight single-byte alphanumeric characters. (Page 44)
- If you have forgotten the password, please consult your authorized dealer.

7 Click "Admin.Network" in the main menu

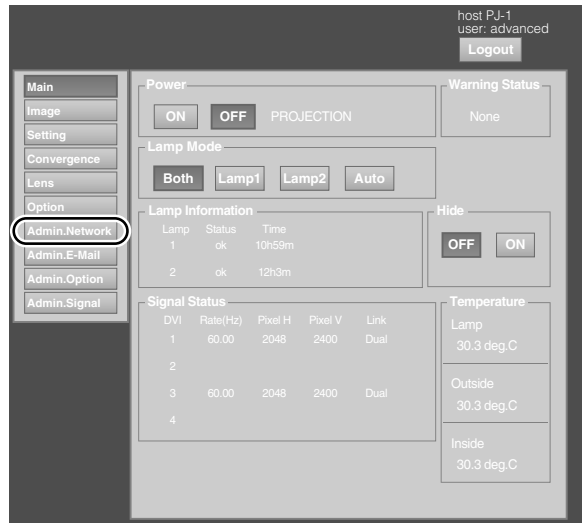

8 Set the IP address for this projector

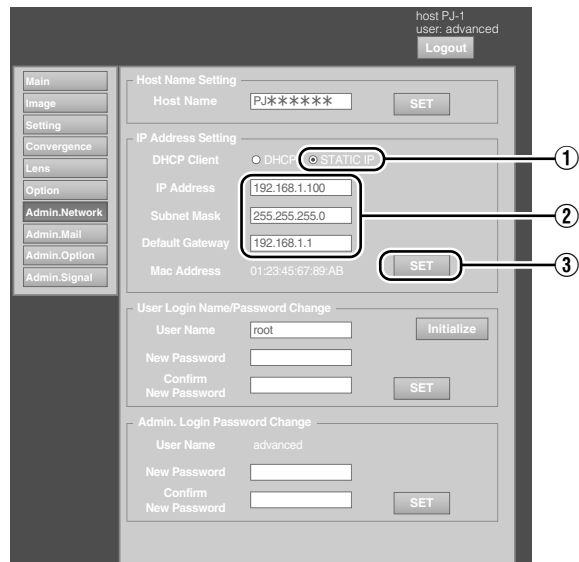

- 1 Select "STATIC IP" in "DHCP Client"
- 2 Enter the values for "IP Address", "Subnet Mask" and "Default Gateway"
- 3 Click "SET"

NOTE:

- Access from computers may not be successful as this projector's IP address has been changed. Set and change the computer's IP address when accessing this projector.

Assigning IP Address from the DHCP Server

The IP address is automatically assigned by the DHCP server.

1 After connecting, turn on the main power

- Refer to Page 24 on the details of connection.
- Refer to Page 25 on procedures to turn on the main power.

2 Set the “DHCP Client” setting of this projector to “DHCP”

- The “DHCP Client” of this projector is set to “STATIC IP” (the DHCP client function is OFF) by default. When assigning an IP address from the DHCP server, access this projector from the computer to alter the settings. For details on the setting procedures, refer to “Setting (Changing) the IP address of this projector”. (Page 27)

NOTE:

- Please consult the network administrator on the IP address assigned to this projector.
- When “DHCP Client” is set to “DHCP”, and if the projector is started up in a LAN where a DHCP server does not exist, the projector will start up using the default IP address instead.

CAUTION:

- Configure the DHCP server such that the same IP address is assigned to the “Mac Address” of this projector by the DHCP server at all times. Connection may fail if the above setting is not performed.

Connecting this projector and the computer using a USB cable

You can connect this projector and the controlling computer using a USB cable.

- You need to install a driver in order to connect the projector and computer using a USB cable.

NOTE:

- For details on the installation of the USB driver, please consult your authorized dealer.

Using the Mail Delivery Feature

This feature enables delivery of mail (error message) to the preset e-mail address when error occurs inside this projector unit.

Connection Example (When DHCP Server is Used)

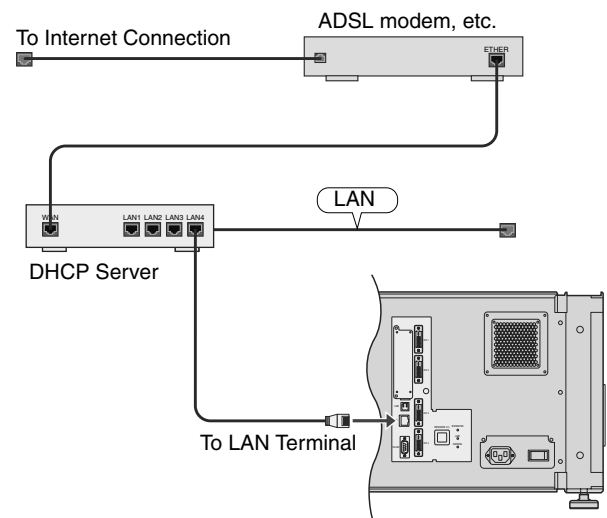

Projecting Image

If setting for this projector is not completed, refer to “User Settings Menu” (☞ Page 33) upon turning on the power and configure the settings accordingly. Once the basic settings are configured, this projector can be used by simply performing the following operation procedures.

PREPARATION: _____

- Remove the lens cap.
- Connect this projector to the computer. (☞ Page 21, 23)
- Connect the LAN cable. (☞ Page 24)

1 Set this projector to the standby mode, and display the main menu

- Refer to “Turning On the Main Power” (☞ Page 25), and steps 4 to 6 of “Assigning a static IP address” (☞ Page 28).
- The [STANDBY/ON] indicator lights up in red.

2 Click the “ON” button under the “Power” item of the main menu to project the image

- The power of this projector turns on, and formatting is done taking a few minutes. A gray image will be displayed during formatting. The projected image appears once formatting ends.
- The [STANDBY/ON] indicator lights up in green.

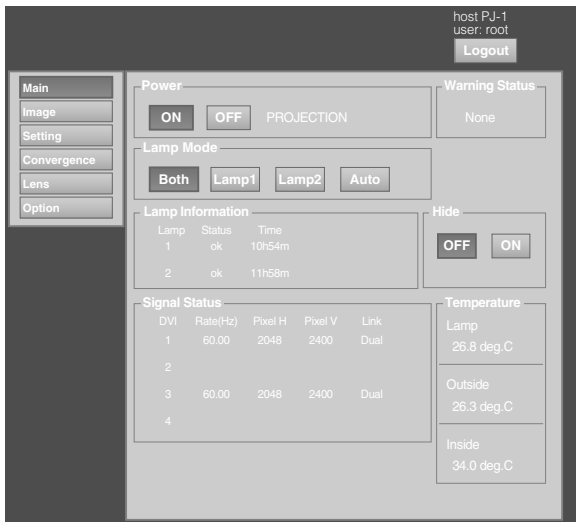

NOTE: _____

- You can also turn on the power by pressing the [OPERATE I/⏻] button on the projector unit for more than one second.
- The image may flicker for a few seconds immediately after projection starts. This is not a malfunction.
- After the lamp lights up, it takes about 1 minute or longer for the brightness of the video image on the screen to stabilize.

3 Adjust the zoom ratio (screen size) (when zoom lens is in use)

You can adjust the focus using the “Zoom” item of the Lens menu.

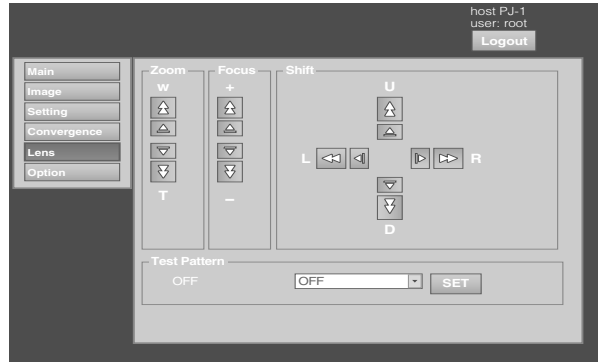

- **To enlarge the screen size:**
Press the “W” (Wide) end of “Zoom”
- **To reduce the screen size:**
Press the “T” (Tele) end of “Zoom”

NOTE: _____

- The screen size changes each time you click on the inner buttons (▲/▼). (Fine control)
The outer buttons (△/▽) change the screen size when they are depressed. (Coarse control)

4 Adjust the position of the projection screen

You can adjust the focus using the “Shift” item of the Lens menu.

- **To shift the image upward:**
Press the “U” end of “Shift”
- **To shift the image downward:**
Press the “D” end of “Shift”
- **To shift the image rightward:**
Press the “R” end of “Shift”
- **To shift the image leftward:**
Press the “L” end of “Shift”

NOTE: _____

- When a zoom lens is used, the adjustment range for lens shift is between 0 % to ±50 % in the vertical direction, and between 0 % to ±25 % in the horizontal direction (during single-screen display).
When a short focal length lens is used, the adjustment range for lens shift is between 0 % to ±15 % in the vertical direction, and between 0 % to ±5 % in the horizontal direction (during single-screen display). (☞ Page 16)
- The position changes each time you click on the inner buttons (▲/▼). (Fine control)
The image shifts when the outer buttons (△/▽) are depressed. (Coarse control)
- The lens shift feature does not function if the lens mechanism is secured. (☞ Page 16 “Lens Fixation Mechanism”)

5 Adjust the focus

You can adjust the focus using the “Focus” item of the **Lens** menu.

● To move the focus point closer:

Press the “+” (Near) end of “Focus”

● To move the focus point away:

Press the “-” (Far) end of “Focus”

NOTE:

- The focus changes each time you click on the inner buttons (▲/▼). (Fine control)
The outer buttons (△/▽) change the focus when they are depressed. (Coarse control)

6 Select a screen mode for projection

You can specify the screen mode using “Display Mode” of the Setting menu. (☞ Page 38)



NOTE:

- The projected image varies according to the mode of connection. (☞ Page 21, 23)

7 Click the “OFF” button under the “Power” item of the Main menu to end the projection

- The projector switches to the cool down mode, and the [STANDBY/ON] indicator appears blinking in red.
- A gray image will be displayed for a maximum duration of 2 minutes during the ending process only after several hours of image projection. The lamp starts cooling down thereafter.
- After exiting the cool down mode, the projector switches automatically to the standby mode, and the [STANDBY/ON] indicator lights up in red.
- You can also turn off the power by pressing the [OPERATE I/⏻] button on the projector unit for more than one second.

Cool down mode

The cool down mode is a function that cools down the lamp for an interval of about 180 seconds after projection ends (ending process). This function is to prevent deformation and damage of the internal components of the projector due to heat from the overheated lamp. It also prevents lamp breakage and shortened lamp life.

- When the projector is in the cool down mode, the [STANDBY/ON] indicator appears blinking in red.
- Do not shut down the main power supply or unplug the power cord when in the cool down mode. Also, do not block the air inlets and vent holes. Doing so may shorten the lamp life and cause a malfunction.

8 Turn the main power at the rear of the projector unit to off [O]

- The [STANDBY/ON] indicator on the projector unit goes off.

CAUTION:

- Do not turn off the main power supply switch when in the cool down mode. Doing so may shorten the lamp life and cause a malfunction.
- Upon using, attach the lens cap to prevent soiling of the lens.
- When the projector is not to be used for a long time, disconnect the power plug.

Useful Features During Projection

■ Hiding the projected image temporarily

The projected image can be hidden by clicking the “ON” button under the “Hide” item of the Main menu or Image menu.

- When the image is not displayed, pressing “OFF” under the “Hide” item to display the hidden image.

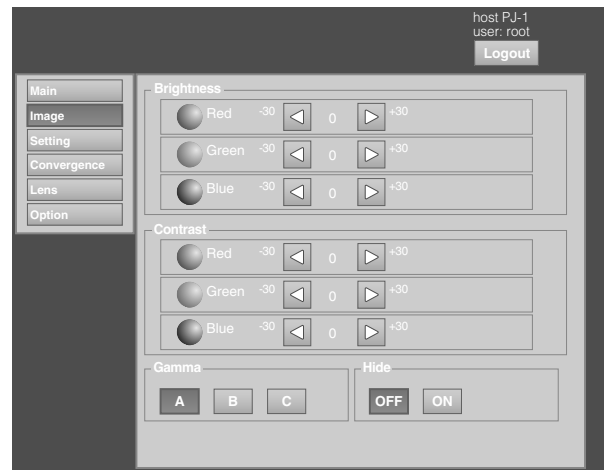

NOTE:

- When the image is hidden, the [STANDBY/ON] indicator appears blinking in green.

Displaying the Menu

1 Enter the IP address assigned in the address field of the Internet Explorer, and click “Go” (👉 Page 28)

- Example: When IP address assigned is “192.168.0.2”, enter “http://192.168.0.2”.

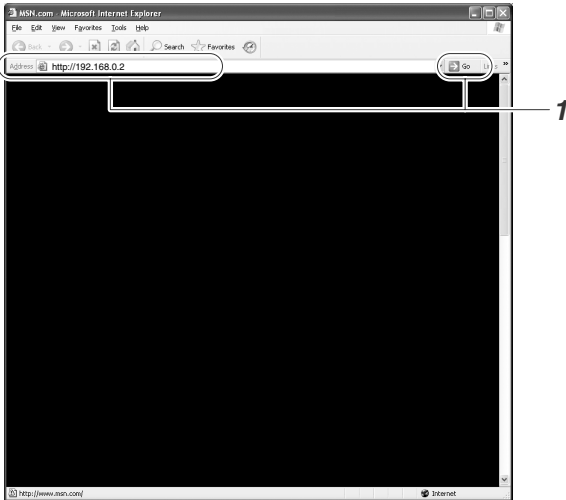

NOTE:

- When “LAN Setting” in Internet Explorer is set to “Use a proxy server for your LAN” it may not be possible to designate addresses directly. Change the proxy settings.
- If a “Security Warning” screen appears, click “OK” and continue.

2 Enter the login name and the password in the “Login Name” and “Password” fields respectively

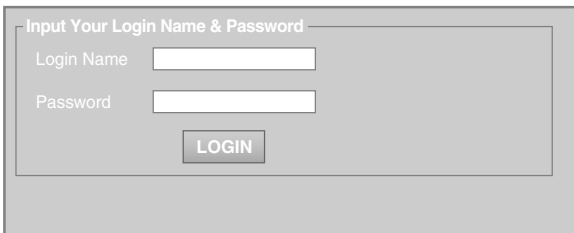
A screenshot of a web form titled "Input Your Login Name & Password". The form has a light gray background. It contains two input fields: "Login Name" and "Password". Below the "Password" field is a button labeled "LOGIN". The form is enclosed in a thin border.

NOTE:

- If you have forgotten the password, please consult your authorized dealer.

3 Click “LOGIN”

- The main menu for this projector appears.

NOTE:

- You can alter the user name and password in the “Admin.Network” menu. Specify a user name and password of not more than eight single-byte alphanumeric characters. (👉 Page 44)

User Settings Menu

After installation and connection are complete, perform the necessary adjustment and setting. Operate the menus using the computer's browser to make adjustments and configure settings.

User Settings Menu Structure

Page Menu Name	Page Display Item	Simplified Description of Item
(1) Main	Power Warning Status Lamp Mode Lamp Information Signal Status Temperature Hide	Power ON/OFF operation Error code display Illumination mode setting Lamp information display Input signal information display Projector's interior temperature display Mute operation
(2) Image	Brightness Contrast Gamma Hide	Brightness adjustment Contrast adjustment Gamma setting Mute operation
(3) Setting	Input Level Display Mode	Input level setting Display method setting
(4) Convergence	Red Blue Test Pattern	Pixel position adjustment Pixel position adjustment Test pattern setting
(5) Lens	Zoom Focus Shift Test Pattern	Zoom adjustment Focus adjustment Image position adjustment Test pattern setting
(6) Option	Flip Lamp Power Back Color Message Display Test Pattern	Image inversion setting Lamp power setting Background color setting Message display setting Test pattern setting

User Settings Menu (Cont'd)

(1) Main Menu

This menu displays the ON/OFF status of the power supply and information on signals input to the projector.

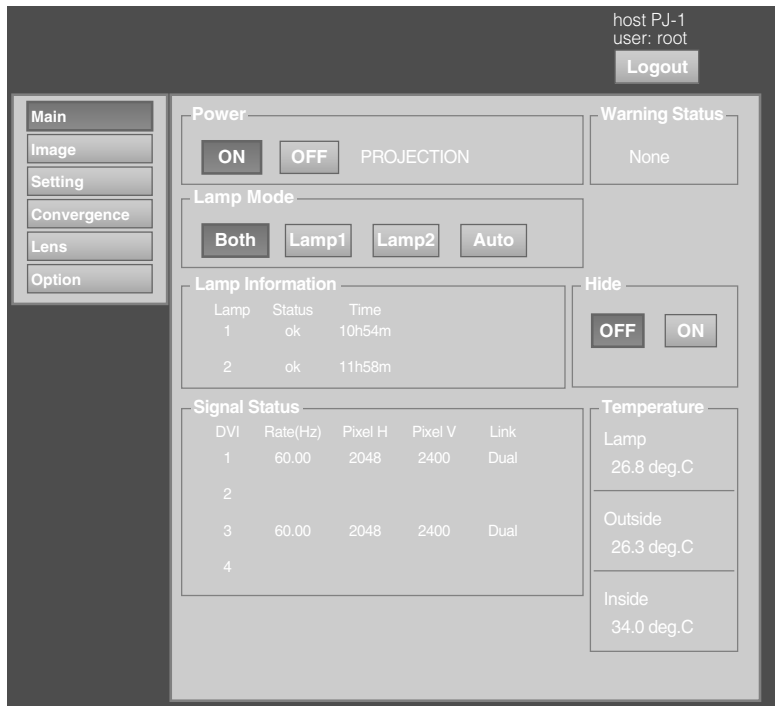

NOTE:

- When the power of this unit is off (main power is on), the “Main”, “Image”, “Setting”, “Convergence”, “Lens” and “Option” menus will be grayed out and will not be selectable.
-

● indicates the factory default.

Item	Setting Value	Description
Power	ON OFF	<p>For turning on/off the lamp selected in “Lamp Mode”.</p> <p>ON : Turns on the lamp. OFF : Turns off the lamp.</p> <p>NOTE:</p> <ul style="list-style-type: none"> The following operating modes of the projector are displayed to the right of the OFF button. <ul style="list-style-type: none"> STANDBY : Standby (OFF) PROJECTION : Lamp Illuminated (ON) FAN ENABLE : FAN Enable (OFF→ON) LAMP ENABLE : LAMP Enable (OFF→ON) DEVICE ENABLE : Elemental Device Enable (OFF→ON) COOLING : Cooling (OFF) EMERGENCY : Error Occurred (Cooling not performed) EMERGENCY COOLING : Error Occurred (Cooling performed) When in the standby mode, clicking the ON button each time switches the mode in the sequence of STANDBY→DEVICE ENABLE→LAMP ENABLE→FAN ENABLE→PROJECTION. Clicking the OFF button when the power is on switches the projector to the cooling mode. The power of the projector cannot be turned on during the cooling process (180 seconds).
Warning Status	—	<p>Displays the latest error number.</p> <p>NOTE:</p> <ul style="list-style-type: none"> For details on the error code and description, please refer to “Warning Status”. (Page 55) “None” is displayed when no error is detected.
Lamp Mode	● Both Lamp1 Lamp2 Auto	<p>For selecting the lamp to turn on during power on.</p> <p>Both : Selects both lamps. Lamp1 : Selects only Lamp 1. Lamp2 : Selects only Lamp 2. Auto : Selects only the lamp with the least lamp time. However, “Lamp1” is selected when both lamps have the same lamp time.</p> <p>NOTE:</p> <ul style="list-style-type: none"> This setting is only available in the “STANDBY”, “COOLING”, “EMERGENCY” and “EMERGENCY COOLING” operating modes.
Lamp Information	—	<p>For displaying the information on Lamp 1 and 2.</p> <p>Status</p> <p>ON : Lamp illuminated OFF : Lamp off Failed : The lamp fails to light up even though the operation of illuminating the lamp is performed.</p> <p>Time : Lamp time (in minutes)</p>

User Settings Menu (Cont'd)

(1) Main Menu (Cont'd)

● indicates the factory default.

Item	Setting Value	Description
Signal Status DVI Rate(Hz) Pixel H Pixel V Link	— — — — —	Displays information on the input signals. DVI : Displays the DVI input terminal number. Rate(Hz) : Displays the vertical frequency. Pixel H : Displays the horizontal resolution. Pixel V : Displays the vertical resolution. Link : Displays the link status of the DVI terminal. NOTE: ● This item is not displayed when there is no signal input. ● The text color of Rate (vertical frequency) turns red in the case of interlaced signal. And the text turns white in the case of progressive signal.
Temperature Lamp Outside Inside	— — —	Displays the interior temperature of the projector. Lamp : Lamp's ambient temperature Outside : External temperature Inside : Internal temperature NOTE: ● The color of the text turns red if the temperature becomes abnormal. ● The text appears white at normal temperature.
Hide	● OFF ON	Enables temporary hiding of the image. OFF : Do not hide image. ON : Hide image. NOTE: ● When the image is hidden, the "STANDBY/ON" indicator appears blinking in green.

(2) Image Menu

This menu is used for adjusting the picture quality.

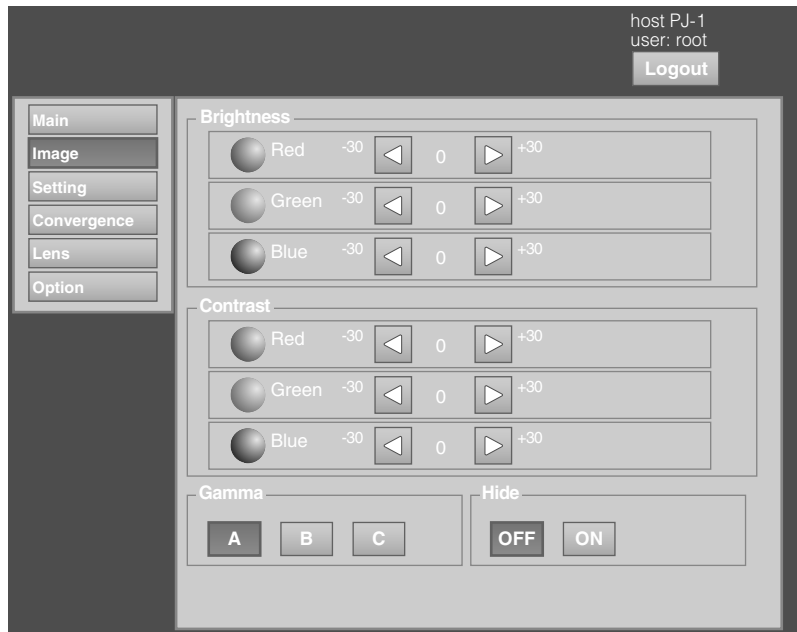

● indicates the factory default.

Item	Setting Value	Description
Brightness		
Red	-30 to +30 (Default Value: 0)	For adjusting the brightness of the red, green, and blue colors.
Green	-30 to +30 (Default Value: 0)	
Blue	-30 to +30 (Default Value: 0)	
Contrast		
Red	-30 to +30 (Default Value: 0)	For adjusting the contrast of the red, green, and blue colors.
Green	-30 to +30 (Default Value: 0)	
Blue	-30 to +30 (Default Value: 0)	
Gamma	● A B C	For specifying the tone characteristics of the image. A : Sets gamma to "2.2". B : Sets gamma to "1.8". C : Sets gamma to "2.6".
Hide	● OFF ON	Enables temporary hiding of the image. OFF: Do not hide image. ON : Hide image. NOTE: _____ ● When the image is hidden, the "STANDBY/ON" indicator appears blinking in green. _____

User Settings Menu (Cont'd)

(3) Setting Menu

This menu is used for specifying the input level of the terminal and the display mode.



● indicates the factory default.

Item	Setting Value	Description
Input Level	<ul style="list-style-type: none"> ● 0-255(PC) 16-235 	For specifying the input level of the video signals. 0-255(PC) : Set to this value under normal circumstances. (Signal level 0 to 255) 16-235 : For specifying when the signal level is between 16 and 235.
Display Mode	<ul style="list-style-type: none"> ● Single Double Cross 	For specifying the display mode of the projection screen. Single : Displays input signals on a single screen. Double : Displays two different input signals on two screens. The left screen displays images of the DVI 1 terminal, and the right screen displays images of the DVI 3 terminal. Cross : Displays four different input signals on four screens. The top left screen displays images of the DVI 1 terminal, the top right screen displays images of the DVI 2 terminal, the bottom left screen displays images of the DVI 3 terminal, while the bottom right screen displays images of the DVI 4 terminal. NOTE: <ul style="list-style-type: none"> ● Please refer to “Connecting Video Signals of the Computer” for details. (Page 20 to 23)

(4) Convergence Menu

This menu is used for correcting color shifts in the optical system.

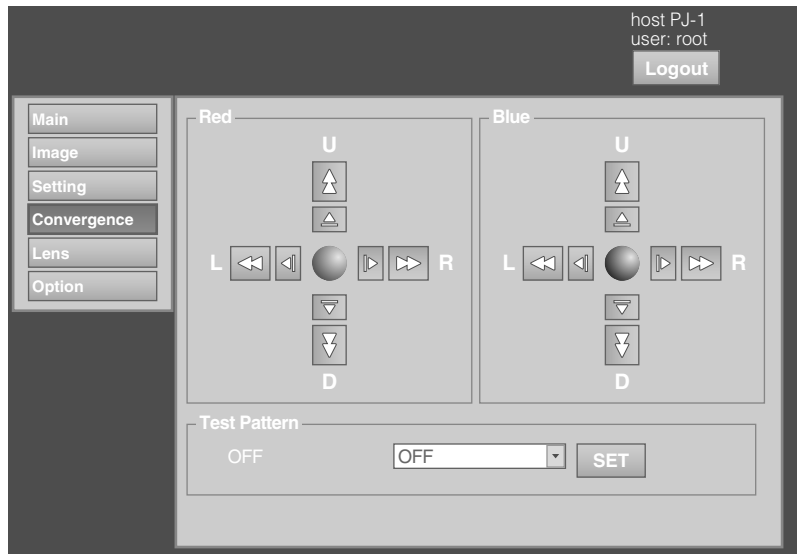

● indicates the factory default.

Item	Setting Value	Description
Red	—	For adjusting the horizontal/vertical position of red and blue colors on the image.
Blue	—	<p>NOTE:</p> <ul style="list-style-type: none"> ● The green color value is fixed. ● The outer buttons are used for adjustment in units of 1/4 pixels, and the inner buttons in units of 1/10 pixels. ● When the image is flipped horizontally or vertically, the horizontal and vertical directions are reversed. ● Use images with a clear outline (such as Color Cross Hatch patterns available in this projector) for adjustment. <p>CAUTION:</p> <ul style="list-style-type: none"> ● When the movement exceeds the limit, the color of the button turns red.
Test Pattern	<p>● OFF</p> <p>Color Bars</p> <p>Color Cross Hatch</p> <p>Cross Hatch</p> <p>Staircase</p> <p>Ramp</p> <p>Flat</p>	<p>For projecting the test pattern.</p> <p>OFF : Do not display the test pattern.</p> <p>Color Bars : Displays the color bar.</p> <p>Color Cross Hatch : Displays the color cross hatch pattern.</p> <p>Cross Hatch : Displays the cross hatch pattern.</p> <p>Staircase : Displays the staircase (white color).</p> <p>Ramp : Displays the ramp pattern (white color).</p> <p>Flat : Displays the flat pattern (white color).</p>

User Settings Menu (Cont'd)

(5) Lens Menu

This menu is used for adjusting the projection lens.

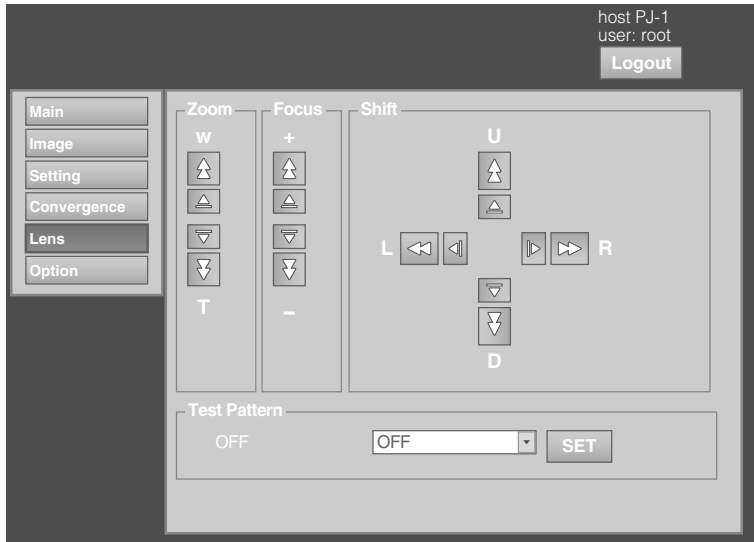

Item	Setting Value	Description
Zoom	—	For adjusting the zoom ratio (screen size). NOTE: _____ <ul style="list-style-type: none"> The zoom position changes each time the inner button is clicked. The zoom position changes when the outer button is depressed. CAUTION: _____ <ul style="list-style-type: none"> Due to backlash, the response may not be immediate.
Focus	—	For adjusting the focus position. NOTE: _____ <ul style="list-style-type: none"> The focus position changes each time the inner button is clicked. The focus position changes when the outer button is depressed. CAUTION: _____ <ul style="list-style-type: none"> Due to backlash, the response may not be immediate.
Shift	—	For adjusting the horizontal and vertical positions of the projection screen. NOTE: _____ <ul style="list-style-type: none"> The shift position changes each time the inner button is clicked. The shift position changes when the outer button is depressed. CAUTION: _____ <ul style="list-style-type: none"> When the movement exceeds the limit, the color of the button turns red. Due to backlash, the response may not be immediate.
Test Pattern	—	For projecting the test pattern. NOTE: _____ <ul style="list-style-type: none"> Same as “Test Pattern” in the Convergence Menu. (Page 39)

(6) Option Menu

This menu is used for specifying settings for the method of screen display, lamp brightness and others.

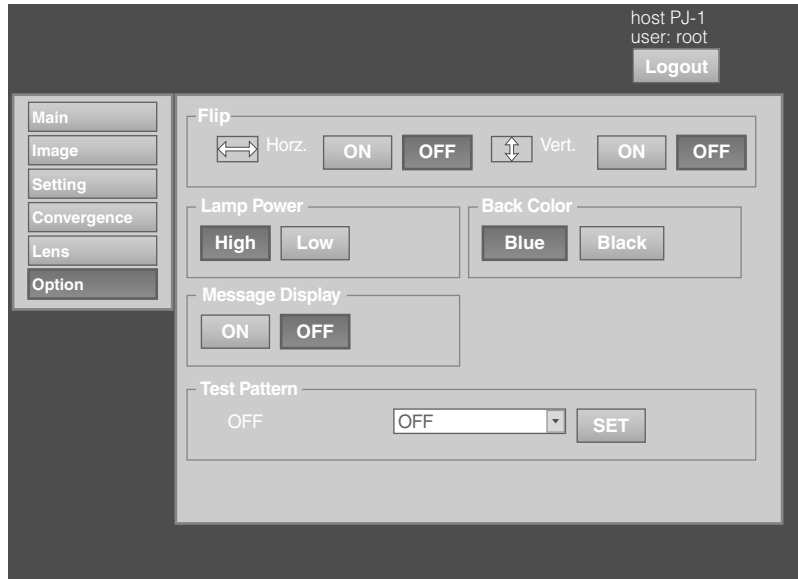

● indicates the factory default.

Item	Setting Value	Description
Flip Horz. Vert.	ON ● OFF ON ● OFF	For specifying settings if images are vertically or horizontally flipped when they are projected from the opposite side of the screen, or when mirrors are used for projection. ON : Flips image horizontally. OFF : Do not flip image horizontally. ON : Flips image vertically. OFF : Do not flip image vertically.
Lamp Power	● High Low	For switching the brightness of the lamp between Low and High.
Back Color	● Blue Black	For specifying the background color during message display or when projection fails, such as when there is no input signal. Blue : Sets the screen to blue color. Black : Sets the screen to black color.
Message Display	ON ● OFF	For specifying whether to display the message. ON : Displays message. OFF : Do not display the test pattern. CAUTION: ● When "OFF" is set, the "No Input", "Out of Range" and "Lamp Time Over" messages will not be displayed on the screen.
Test Pattern	—	For projecting the test pattern. NOTE: ● Same as "Test Pattern" in the Convergence Menu. (Page 39)

Memo :

Administrator Settings Menu

After installation and connection are complete, perform the necessary adjustment and setting. Operate the menus using the computer's browser to make adjustments and configure settings.

Administrator Settings Menu Structure

For details on page menu (1) to (6), refer to "User Settings Menu" (Page 33 to 41).

Page Menu Name	Page Display Item	Simplified Description of Item
(1) Main	Power Warning Status Lamp Mode Lamp Information Signal Status Temperature Hide	Power ON/OFF operation Error code display Illumination mode setting Lamp information display Input signal information display Projector's interior temperature display Mute operation
(2) Image	Brightness Contrast Gamma Hide	Brightness adjustment Contrast adjustment Gamma setting Mute operation
(3) Setting	Input Level Display Mode	Input level setting Display method setting
(4) Convergence	Red Blue Test Pattern	Pixel position adjustment Pixel position adjustment Test pattern setting
(5) Lens	Zoom Focus Shift Test Pattern	Zoom adjustment Focus adjustment Image position adjustment Test pattern setting
(6) Option	Flip Lamp Power Back Color Message Display Test Pattern	Image inversion setting Lamp power setting Background color setting Message display setting Test pattern setting
(7) Admin.Network	Host Name Setting IP Address Setting User Login Password Change Admin. Login Password Change	Host name setting IP address setting User login setting Administrator login setting
(8) Admin.E-mail	E-Mail Setting Test Mail	E-mail setting Test e-mail setting
(9) Admin.Option	Color Depth Frame Lock Mecha. Shutter High Altitude Lamp Time Reset	Color balance setting Frame synchronization setting Mechanical shutter setting High altitude mode setting Resetting lamp time
(10) Admin.Signal	Force Signal Display Mode Signal Status EDID	Input/output signal setting Display method setting Input signal information display EDID information rewrite

Administrator Settings Menu (Cont'd)

(7) Admin.Network Menu

For configuring the network settings.

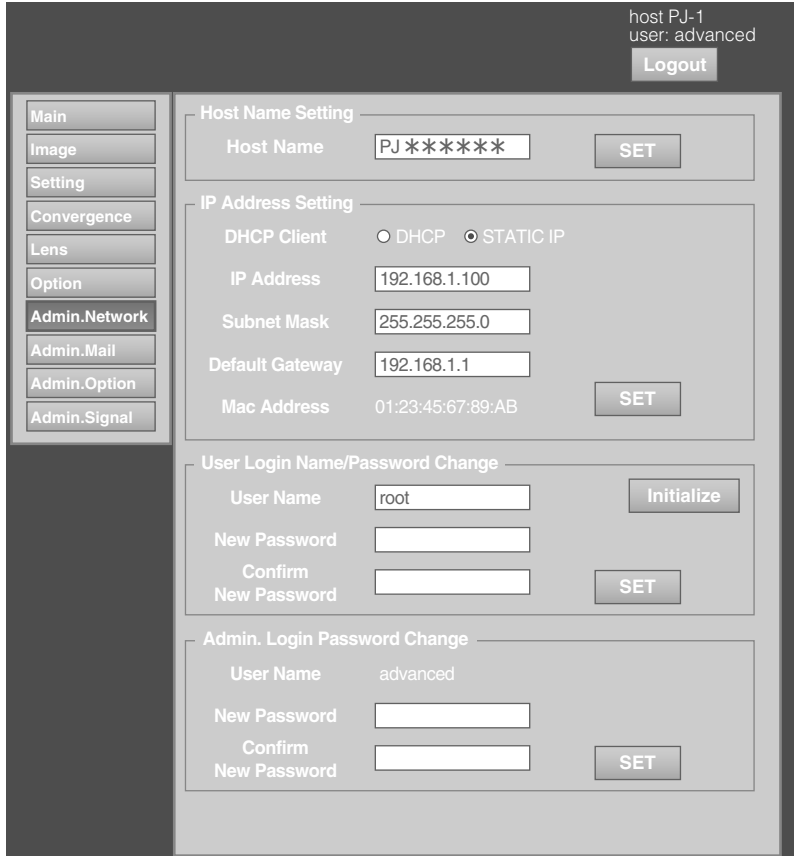

● indicates the factory default.

Item	Setting Value	Description
Host Name Setting Host Name	— (Default Value: PJ*****)	For specifying the host name. NOTE: ● You can change it to a random name. You can input up to 8 characters using single-byte alphanumeric characters and “ - ”. ● “*****” of the default value displays the lower 3 bytes of the MAC address of this projector.
IP Address Setting DHCP Client IP Address Subnet Mask Default Gateway Mac Address	DHCP ● STATIC IP (Default Value: 192.168.0.2) (Default Value: 255.255.255.0) (Default Value: 192.168.0.254) —	For configuring the network settings. DHCP : Select this to acquire the IP address from the DHCP server automatically. STATIC IP : Select this to configure the IP address manually. --- IP Address : Specify the IP address. --- Subnet Mask : Specify the subnet mask. --- Default Gateway : Specify the default gateway. Mac Address : Displays the MAC address. (Cannot be specified)

Item	Setting Value	Description
User Login Name/ Password Change User Name New Password Confirm New Password Initialize	 root — — —	For changing the login name and password. User Name : For changing the login name. New Password : For changing the login password. Confirm New Password : Re-enter the new password. (For confirmation) Initialize : For resetting the username/password. <hr/> NOTE: <ul style="list-style-type: none"> ● You can change it to a random name. You can input up to 8 characters using single-byte alphanumeric characters and “ – ”. ● If you have forgotten the password, please consult any nearby JVC servicing center.
Admin. Login Password Change User Name New Password Confirm New Password Initialize	 advanced — — —	For changing the administrator’s password. User Name : Cannot be changed. (fixed) New Password : For changing the login password. Confirm New Password : Re-enter the new password. (For confirmation) Initialize : For resetting the password. <hr/> NOTE: <ul style="list-style-type: none"> ● You can change it to a random name. You can input up to 8 characters using single-byte alphanumeric characters and “ – ”. ● If you have forgotten the password, please consult your authorized dealer.

Administrator Settings Menu (Cont'd)

(8) Admin.E-mail Menu

This menu is for configuring the mail settings, which sends out an error message to the computer of the preset address when an abnormality occurs within this projector.

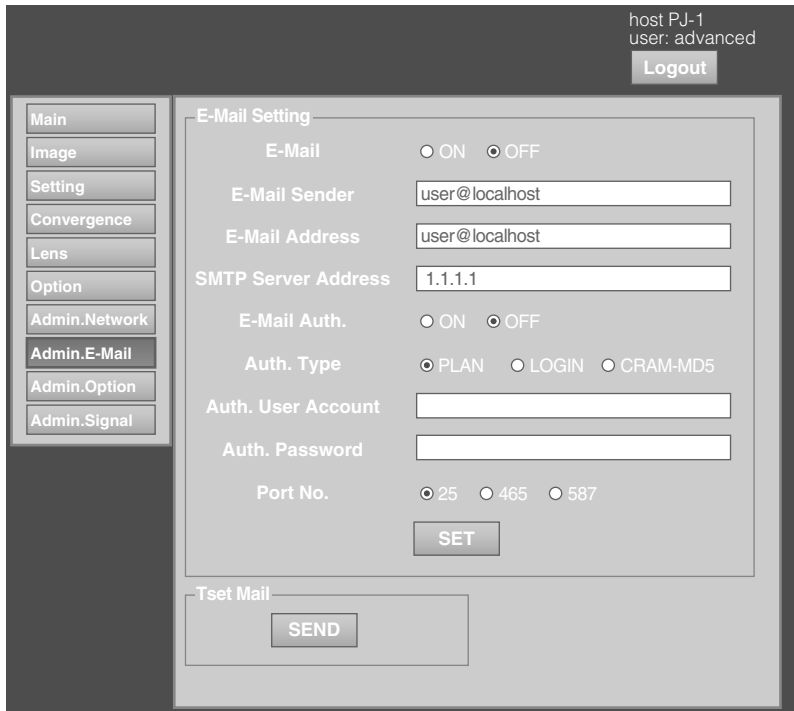

■ Error message sent from this projector

(Example) When error occurs at the DD-RB board

Sender

***** (setting value for "E-Mail Sender")

Mail title

4KPJU2 report mail

Message

Error Code	32 "Trouble with DD-RB circuit board."
System Time	106 h 57 m
Lamp1 Time	41h 59 m
Lamp2 Time	41h 31 m
Lamp Temp.	42 deg.C
Inside Temp.	40 deg.C
Outside Temp.	24 deg.C

NOTE:

- Refer to the code in the "Warning Status" for the error code. (Page 55)

● indicates the factory default.

Item	Setting Value	Description
E-Mail Setting		For configuring the e-mail feature.
E-Mail	ON ● OFF	ON : Use the mail feature. OFF : Do not use the mail feature.
E-Mail Sender	— (Default Value: lower 3 bytes of the MAC address)	For specifying the destination e-mail address of this projector.
E-Mail Address	— (Default Value: user@localhost)	For specifying the destination e-mail address. NOTE: ● Specify an address up to a maximum of 64 characters. ● Make use of single-byte alphanumeric characters and “_” “.” “_” “@”.
SMTP Server Address	— (Default Value: 1.1.1.1)	For specifying the address of the outgoing mail server (SMTP). NOTE: ● Specify an address up to a maximum of 15 characters. ● Make use of numbers and “.”.
E-Mail Auth.	ON ● OFF	ON : Enable the e-mail authentication feature. OFF : Disable the e-mail authentication feature.
Auth. Type	● PLAIN LOGIN CRAM-MD5	For configuring the e-mail authentication type. PLAIN : Set e-mail authentication to “PLAIN”. LOGIN : Set e-mail authentication to “LOGIN”. CRAM-MD5 : Set e-mail authentication to “CRAM-MD5”.
Auth. User Account	—	For configuring the account name during e-mail authentication. NOTE: ● Specify an address up to a maximum of 31 characters. ● Make use of single-byte alphanumeric characters and “-”.
Auth. Password	—	For configuring the password during e-mail authentication. NOTE: ● Specify an address up to a maximum of 31 characters. ● Make use of single-byte alphanumeric characters and “-”.
Port No.	● 25 465 587	For configuring the SMTP server port number when using the e-mail authentication feature.
Set	—	The details of the configuration will be saved.
Test Mail	—	When the “SEND” button is clicked, the test mail with the contents configured in the E-Mail Setting will be sent.

Administrator Settings Menu (Cont'd)

(9) Admin.Option Menu

This menu is used for specifying settings including image and option, and for resetting the lamp.

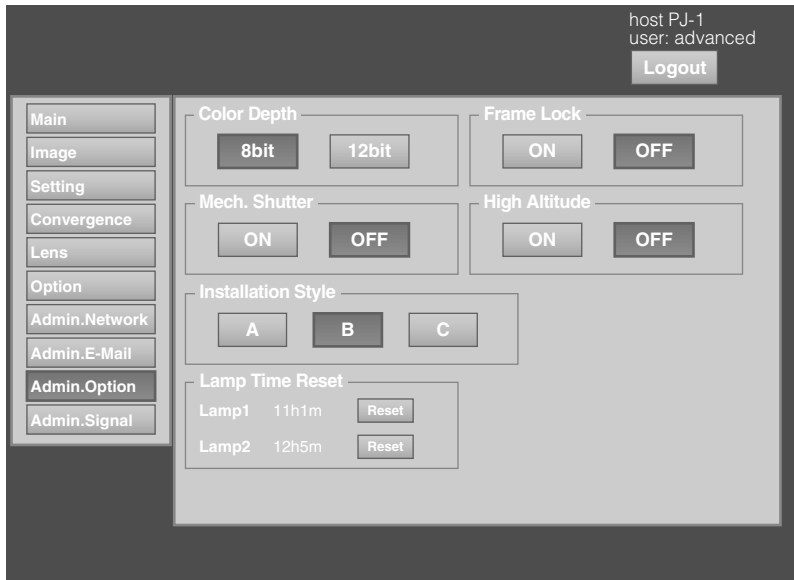

● indicates the factory default.

Item	Setting Value	Description
Color Depth	● 8bit 12bit	For configuring the color balance.
Frame Lock	● ON OFF	For configuring the frame synchronization of each DVI input.
Mech. Shutter	ON ● OFF	For configuring to ON/OFF the Mech. Shutter (model number: PK-VS4MSG, optional, sold separately). Click ON to operate the Mecha Shutter.
High Altitude	ON ● OFF	Configure to ON when using at high altitude (above 1,500 m).
Installation Style	A ● B C	For configuring the installation method (orientation mode) of the projector. A : Orientation mode A (upward installation) B : Orientation mode B (horizontal installation/normal mode) C : Orientation mode C (downward installation)
Lamp Time Reset Lamp1 Lamp2	—	For resetting the lamp time of Lamp 1 and 2.

(10) Admin.Signal Menu

This menu is for configuring settings such as display format, and for rewriting EDID.

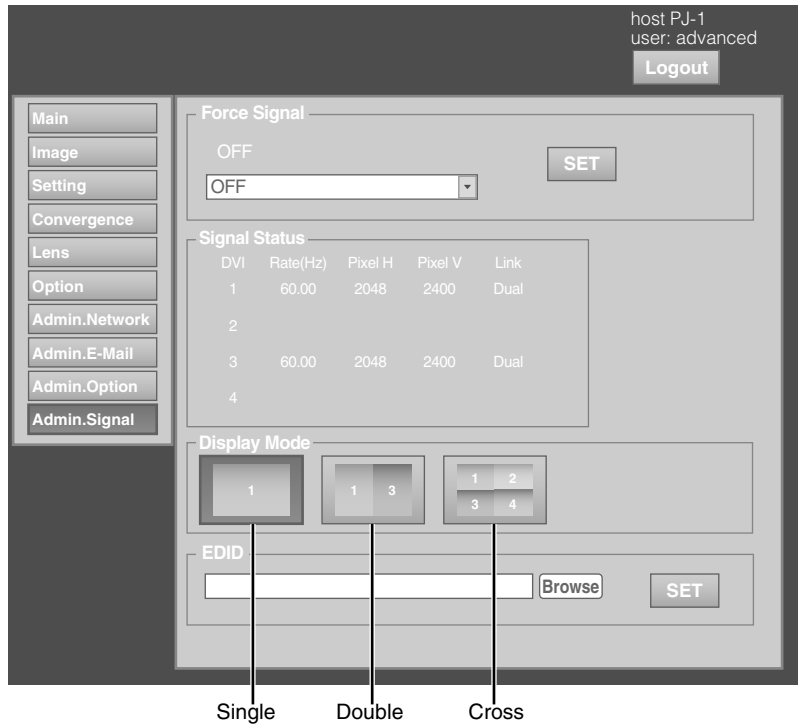

● indicates the factory default.

Item	Setting Value	Description
Force Signal	● OFF	<p>For forcibly configuring the output signal. Make use of this setting when there is no display due to configuration changes at the input source.</p> <p>NOTE:</p> <ul style="list-style-type: none"> Some portions of the image may not be displayed and the image may become noisy. <hr/> <p>OFF : Turns off the display by force.</p> <p>4096 × 2400, None, Dual : Displays a normal screen using dual link.</p> <p>4096 × 2400, None, Single : Displays a normal screen using single link.</p> <p>2048 × 2400, 2Stripe, Dual : Displays a 2 stripes screen using dual link.</p> <p>2048 × 2400, 2Stripe, Single : Displays a 2 stripes screen using single link.</p> <p>2048 × 1200, Cross, Dual : Displays a cross screen using dual link.</p> <p>2048 × 1200, Cross, Single : Displays a cross screen using single link.</p> <p>1024 × 2400, 4Stripe, Dual : Displays a 4 stripes screen using dual link.</p> <p>1024 × 2400, 4Stripe, Single : Displays a 4 stripes screen using single link.</p>
	4096 × 2400, None, Dual	
	4096 × 2400, None, Single	
	2048 × 2400, 2Stripe, Dual	
	2048 × 2400, 2Stripe, Single	
	2048 × 1200, Cross, Dual	
	2048 × 1200, Cross, Single	
	1024 × 2400, 4Stripe, Dual	
	1024 × 2400, 4Stripe, Single	

Administrator Settings Menu (Cont'd)

(10) Admin.Signal Menu (Cont'd)

● indicates the factory default.

Item	Setting Value	Description
Signal Status DVI Rate(Hz) Pixel H Pixel V Link	— — — — —	Displays information on the input signals. Same as "Signal Status" in the User Menu. DVI : Displays the DVI input terminal number. Rate(Hz) : Displays the vertical frequency. Pixel H : Displays the horizontal resolution. Pixel V : Displays the vertical resolution. Link : Displays the link status of the DVI terminal. <hr/> NOTE: ● This item is not displayed when there is no signal input. ● The text color of Rate (vertical frequency) turns red in the case of interlaced signal. And the text turns white in the case of progressive signal.
Display Mode	● Signal Double Cross	For specifying the display mode of the projection screen. Same configuration as "Display Mode" in the User Menu. Signal : Displays input signals on a single screen. Double : Displays two different input signals on two screens. The left screen displays images of the DVI1 terminal, and the right screen displays images of the DVI3 terminal. Cross : Displays four different input signals on four screens. The top left screen displays images of the DVI1 terminal, the top right screen displays images of the DVI2 terminal, the bottom left screen displays images of the DVI3 terminal, while the bottom right screen displays images of the DVI4 terminal.
EDID	—	For rewriting EDID. Click the "Browse" button and select an EDID file. Click the "SET" button to start writing. Write "OK" will be displayed for each channel. "NG (number)" is displayed when writing fails. Error Code 1: System error 7: Unable to execute due to power off 8: Unable to rewrite due to DVI cable connection <hr/> CAUTION: ● Do not turn off the power during rewrite. ● The EDID file capacity is within 256 byte. ● Rewriting to individual channel is not available. ● It is not possible to move on to other pages during rewrite. <hr/> NOTE: ● EDID: Extended Display Information Data A data to describe the specifications (resolution, model number, etc.) of the projector. The compatible transmitting device will output the optimum video signal based on this data.

Troubleshooting

Check the following points before sending this product for repair.
The following phenomena are not malfunctions.

■ **If there is no abnormality on the screen when the phenomena below appear, they are not malfunctions.**

- The top or front part as well as the rear of the projector unit is hot
- A creaking sound is heard from the projector
- Device noise is heard from the interior of the projector
- There is color bleeding on the screen

■ **When the projector fails to run properly due to external noises, perform the following operations.**

- ① Check to ensure that the power is shut down. Unplug the power cord, and insert again.
- ② Turn on the power of the projector.

■ **A sound maybe heard when the lamp burn out. However, this is not a hazard.**

■ **D-ILA devices are manufactured using extremely high-precision technology. However, some of the pixels may not lit up or remain permanently lit up.**

Symptom	Probable Cause	Corrective Action	Reference Page
Power is not supplied	● Is the power cord disconnected?	● Insert the power cord (plug) properly.	☞ Page 25
	● Is the main power supply switched turned on?	● Turn on the main power supply switch of the projector unit.	☞ Page 25
	● Is the lamp in the cool down mode?	● Turn on the power again after the cool down mode ends.	☞ Page 31
	● Is the lamp protection function triggered? (This function is triggered when the power shuts down such as during power failures.)	● Wait till the temperature of the lamp has gone down. (Turn on the main power supply switch to run the fan and cool down the lamp.) Turn on the power after about 180 seconds.	—
Image is dark	● Is the lamp near exhaustion?	● Check the “Lamp Information” setting of the Main menu. When the lamp life is near its end, please consult your authorized dealer.	☞ Page 35
Projector works when the power is turned on, but stops abruptly after a few minutes	● Are the air inlets and vent holes blocked?	● Turn off the main power supply switch, and remove the blockage. After removing, turn on the power again.	☞ Page 12 to 14, 31
	● Is the temperature of the room high?	● Set the temperature of the room or the surrounding temperature of this projector to an appropriate level.	☞ Page 60
	● Are the filters dirty?	● Clean the filters.	☞ Page 58
Video image does not appear	● Is the lens cap removed?	● Remove the lens cap.	☞ Page 12
	● Are devices properly connected?	● Connect the devices correctly.	☞ Page 21, 23
	● Is the power of the connected devices turned on?	● Turn on the power of the connected devices.	—
	● Are correct signals being output from the connected devices?	● Configure the connected devices correctly.	—
	● Are the signals of the connected devices possible input signals?	● Check to ensure that they are possible input signals, and input compatible signals accordingly.	☞ Page 20, 22
	● Is the image temporarily hidden?	● Set “Hide” of the Main menu or Image menu to “OFF” to display the image.	☞ Page 31, 36, 37

Troubleshooting (Cont'd)

Symptom	Probable Cause	Corrective Action	Reference Page
Video image is blur	<ul style="list-style-type: none"> Is the projector out of focus? 	<ul style="list-style-type: none"> Adjust the focus using “Focus” of the Lens menu. 	<ul style="list-style-type: none"> Page 31, 40
	<ul style="list-style-type: none"> Is the projection distance too short or too long? 	<ul style="list-style-type: none"> Set it to a correct distance. 	<ul style="list-style-type: none"> Page 18, 19
Image is unusually dark or bright	<ul style="list-style-type: none"> Is the brightness level properly adjusted? 	<ul style="list-style-type: none"> Adjust accordingly using “Brightness” of the Image menu. Adjust “Lamp Power” in the Option menu. 	<ul style="list-style-type: none"> Page 37 Page 41
Coloring of the image is poor or distorted	<ul style="list-style-type: none"> Is the contrast level properly adjusted? 	<ul style="list-style-type: none"> Adjust accordingly using “Contrast” of the Image menu. 	<ul style="list-style-type: none"> Page 37
	<ul style="list-style-type: none"> Are the signals of the connected devices possible input signals? 	<ul style="list-style-type: none"> Check to ensure that they are possible input signals, and input compatible signals accordingly. 	<ul style="list-style-type: none"> Page 20, 22
	<ul style="list-style-type: none"> Is the input cable correctly connected? 	<ul style="list-style-type: none"> Connect the input cable correctly. 	<ul style="list-style-type: none"> Page 21, 23
Projection position on the screen has shifted	<ul style="list-style-type: none"> Has the setup position of the projector been shifted? 	<ul style="list-style-type: none"> Check the setup position of the projector. 	<ul style="list-style-type: none"> —
Image disappears suddenly	<ul style="list-style-type: none"> Are the video signals correctly input? 	<ul style="list-style-type: none"> Check the signals and connection. 	<ul style="list-style-type: none"> Page 20 to 23
Images do not appear on the two-screen mode display	<ul style="list-style-type: none"> Are the DVI 1 and DVI 3 terminals connected for input? 	<ul style="list-style-type: none"> To display images in the two-screen mode, connect the DVI 1 and DVI 3 terminals. The left screen displays images of the DVI 1 terminal, and the right screen displays images of the DVI 3 terminal. 	<ul style="list-style-type: none"> Page 22, 23
Images do not appear immediately after power is turned on	<ul style="list-style-type: none"> Formatting is in progress. 	<ul style="list-style-type: none"> Please wait for a maximum duration of 3 minutes for the formatting progress to end. 	<ul style="list-style-type: none"> Page 30
The screen does not darken immediately when the projection has ended	<ul style="list-style-type: none"> The ending process is in progress. 	<ul style="list-style-type: none"> Please wait for a maximum duration of 2 minutes for the ending progress to complete after several hours of image projection. 	<ul style="list-style-type: none"> Page 31

What to do when these messages are displayed

Messages are displayed when the lamp life has expired and when there is input of signals that cannot be used.

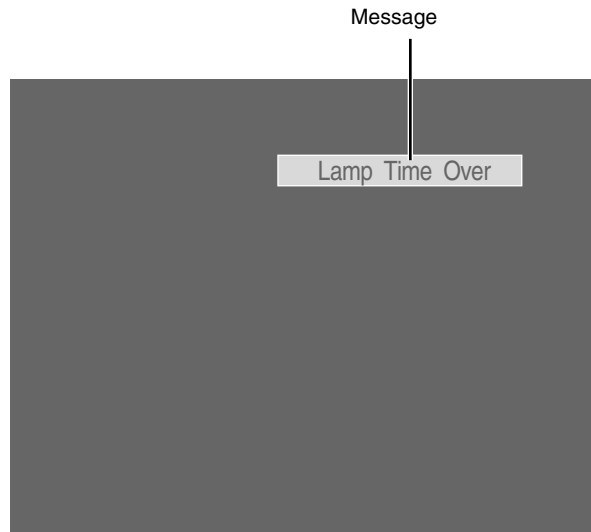

Message	Cause (Details)
Lamp Time Over	<ul style="list-style-type: none"> • Displayed when the lamp time has exceeded 2000 hours. The message is displayed for a period of 3 minutes during each projection. <ul style="list-style-type: none"> → Replace with a new lamp unit. For details on replacement of the lamp unit, please consult your authorized dealer.
Out of Range	<ul style="list-style-type: none"> • When there is input of video signals that cannot be used with this unit <ul style="list-style-type: none"> → Input video signals that can be used.
No Input	<ul style="list-style-type: none"> • When no device is connected to the input terminal • When the input terminal is connected but there is no signal <ul style="list-style-type: none"> → Input the video signals.

NOTE:

- The messages will not be displayed under factory default conditions.
- Set “Message Display” in the Option menu to “ON”. (☞ Page 41)

Warnings Using Indicators

The lamp time and warning mode are indicated using the indicator.
For indicator displays during normal operation, refer to the note below.

No.	Indicator			Description
	STANDBY/ ON	LAMP	WARNING	
1	*1	Light On (Yellow)	-	About time to replace lamp (Lamp time has exceeded 1900 hours.)
2				When the lamp life has expired (Lamp time has exceeded 2000 hours. Message displayed. (☞ Page 53))
3	*2	Blinking (Yellow)	Light On (Red)	When lamp does not light up and projection fails
4				When the lamp goes off during projection
5	*2	-	Light On (Red)	Temperature around the lamp is high
6				When the external temperature is unusually high
7				When the internal temperature is unusually high
8				When an abnormality has occurred in the cooling fan
9				When error occurs in the circuit operation
10	*1	Blinking (Yellow)	-	One of the lamp does not turn on

*1: The indicator lights up in red when in the standby mode, and in green when in the operating mode.

*2: The indicator lights up in red when in the warning mode, and blinks in red when in the cool down mode.

■ Measures when the warning mode appears

When the projector switches to the warning mode (Nos. 3 to 9), projection stops automatically, and the cooling fan runs for about 180 seconds.

After the cooling fan stops running, turn off the main power supply switch, and remove the power plug from the outlet. Perform the following checks and take the corresponding measures.

No.	Check	Measure
3	● Check whether the projector has been subject to shock during operation.	● Turn on the power again.
4		
5	● Check whether the air inlets are blocked by objects. ● Check to ensure that the external temperature of the projector is normal.	● Allow some time for the projector to cool down.
6		
7		
8		
9		

If the warning indication is displayed again, turn off the main power supply switch after the cooling fan stops running. Then pull out the power plug from the power outlet. Call your authorized dealer for repair.

NOTE:

- Indicator display during normal condition.

Indicator	Description		
	STANDBY/ ON	LAMP	WARNING
Light On (Red)	-	-	When in the standby mode.
Light On (Green)	-	-	When power is supplied (operating mode).
Blinking (Red)	-	-	When cooling down (cool down mode). (☞ Page 31)
Blinking (Green)	-	-	When the projected image is temporarily hidden. (☞ Page 31)

Warning Status

The latest error code (Warning Status) appears in the Main Menu when an abnormality occurs in the projector. Error details are as follows:

Error Code	Meaning
1	Lamp 1 does not turn on.
2	Accumulated lamp time for Lamp 1 has exceeded 2000 hours.
6	Lamp 1 goes off during projection.
8	Abnormally high temperature in the projector.
9	Abnormally high temperature around the intake vent.
A	Abnormally high ambient temperature around the lamp.
15	The lamp cover is open.
30	Trouble with CPU circuit board.
31	Trouble with MAIN circuit board.
32	Trouble with DD-RB circuit board.
33	Trouble with DD-G circuit board.
40	FAN1 (the cooling fan for Lamp 1) has stopped.
41	FAN2 (the cooling fan for Lamp 2) has stopped.
42	FAN3 (the cooling fan for overall exhaust/prism) has stopped.
43	FAN4 (the auxiliary cooling fan for exhaust) has stopped.
44	FAN5 (the cooling fan for the lighting system (PCS)) has stopped.
45	FAN6 (the cooling fan for the device) has stopped.
46	FAN7 (the cooling fan for the MAIN circuit board) has stopped.
47	FAN8 (the cooling fan for the DD circuit board) has stopped.
48	FAN9 (the cooling fan for the power supply of the circuit) has stopped.
49	FAN10 (the cooling fan for the power supply of Lamp 1) has stopped.
4A	FAN11 (the cooling fan for the power supply of Lamp 2) has stopped.
50	Trouble with mechanical shutter.
51	Lamp 2 does not turn on.
52	Accumulated lamp time for Lamp 2 has exceeded 2000 hours.
56	Lamp 2 goes off during projection.

RS-232C Interface

You can control this projector via a computer by connecting the computer to this unit using a RS-232C cross cable (D-sub 9 pins). The commands to control this unit and the response data format against the received commands are explained here.
 For details, please consult your authorized dealer.

Communication Specifications

Communication specifications for this unit are as follows:

Transfer Rate	19200 bps
Data Length	8 bit
Parity	None
Stop Bit	1 bit
Flow Control	None

Command Format

■ Command Data Format (PC→Projector)

When sending a control command to this unit, use the following data format:



- Header : Designates the head of data and the data type.
 “!” (21h): Assigns command to the projector (Command)
 “?” (3Fh): Query to the projector (Asking command)
 - ID : “1”: Identification number of the projector (Factory setting is 1)
 - SP : Designates the delimiter between ID and command, command and parameter, as well as parameter and parameter. (20h)
 - CR : Designates the terminal of the data. (0Dh)
- * [] is not necessary for Asking command.

■ Response Data Format (Projector→PC)

Upon executing a control command, this unit sends back response data to the computer in this format.



- Header : Designates the head of the response data.
 “@” (40h): Fetches data from the projector
 - ID : “1”: Identification number of the projector (Factory setting is 1)
 - SP : Designates the delimiter between ID and normal termination status, normal termination status and parameter, as well as parameter and parameter. (20h)
 - Normal Termination Status : “0” (30h)
 - CR : Designates the terminal of the data. (0Dh)
- * [] is not applicable when sending commands to the projector.

■ Parameters used for the data format

The following 2 types of parameters are used for command and response data:

(1) ON/OFF (2) Special Parameter

Each parameter is as follows:

(1) ON/OFF

Shows the status (ON or OFF) of the unit, such as POWER and HIDE.

Character	Hex	Meaning
0	30	OFF
1	31	ON

(2) Special parameters

Operation mode parameters

Character	Hex	Meaning
0000	30 30 30 30	Standby state
0001	30 30 30 31	Power ON state
0002	30 30 30 32	Cooling state
0003	30 30 30 33	Emergency cooling state
0004	30 30 30 34	Emergency state

DHCP client parameters

Character	Hex	Meaning
0	30	DHCP
1	31	STATIC IP

IP address parameters

Display the IP address using the dot (".") (2HE) delimiter.

Example: "192.168.0.10"

■ External control command table

Function	Command	Setting		Asking		Data Type	
		Power On	ELSE	Power On	ELSE	ON/OFF	Special Parameter
Power	U0F	✓ (OFF)	✓ (ON)	—	—	✓	—
Hide	U00	✓	—	✓	—	✓	—
Operation Mode	UA0	—	—	✓	✓	—	Standby...
DHCP Client	UD2	✓	✓	✓	✓	—	DHCP...
IP Address	UD3	✓	✓	✓	✓	—	192.168. ...
Network Restart	UDC	✓	✓	✓	✓	—	[0] Fixed

NOTE:

- After configuring "DHCP Client" and "IP Address", execute "Network Restart".
-

Maintenance

Turn off the power of the projector unit, and unplug the power cord when cleaning or replacing the filter.

Cleaning and Replacing the Filter

Clean the filter regularly. If the filter is soiled, air intake efficiency may deteriorate, thus resulting in malfunction of the product. Replace with a new one if the filter fails to remove dust thoroughly or if it is damaged. Failure to do so may cause dust to enter the projector and shadows to appear on the projected image. If dirt has entered this product or if you need to purchase the filter, please consult the authorized dealer from which this product is purchased or any nearby JVC servicing center.

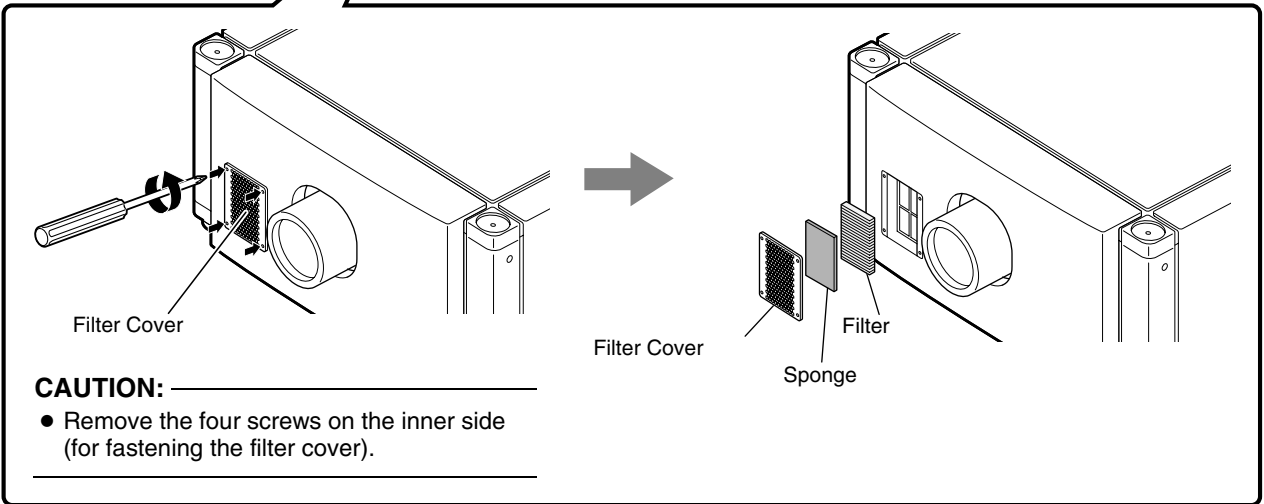
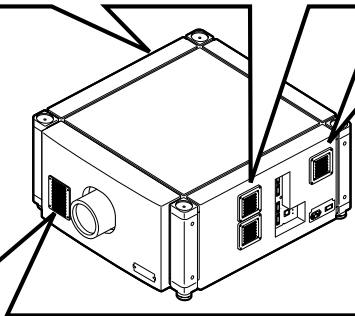
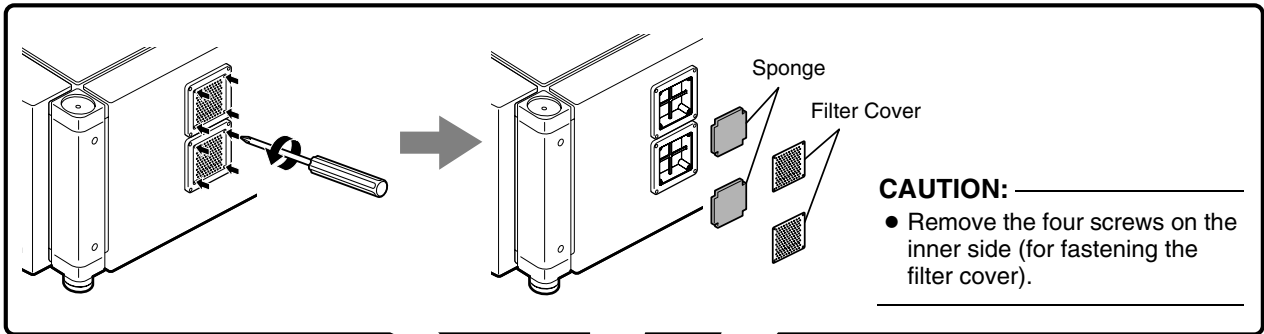

1 Remove the filter cover

The filter is located at the front side of the projector unit.

2 Remove the sponge and filter

Hold the center of the filter using your fingers, and pull the filter toward you to remove it.

3 Clean the sponge and filter

Remove any dirt or dust using a vacuum cleaner.

CAUTION:

- Do not clean using a flammable air duster. This may cause fire.
-

4 Mount the sponge and filter

Mount the filter and sponge to the projector using the reverse removed procedure.

Finally, check to ensure that the filter cover is firmly mounted.

NOTE:

- Mount the filter correctly. Failure to do so may cause the projector to malfunction.
 - The projector may stop operating if a damaged filter or filter panel is used. In this case, replace the filter or filter panel with a new one.
-

Routine Servicing

■ Clean dirt on the cabinet

Do this with a soft cloth. In case of heavy soiling, soak a cloth in neutral detergent diluted with water, wring dry and wipe, followed by wiping again using a dry cloth. Pay attention to the following to prevent the cabinet from deteriorating in condition, getting damaged, or the paint from coming off.

- Do not wipe with a stiff cloth
- Do not wipe with force
- Do not wipe with thinner or benzene
- Do not spray volatile chemicals like insecticide
- Do not allow prolonged contact with rubber or plastic products

■ Remove dirt that is attached to the vent holes

Do this using a vacuum cleaner. Wipe using a cloth if a vacuum cleaner cannot be used. Leaving dust attached may prevent adjustment of the internal temperature and result in malfunction of the projector.

■ Clean dirt on the lens

Do this using commercial blowers or lens cleaning papers (for cleaning glasses and cameras). Do not use fluid-type cleaning agents. This may lead to peeling of the surface coating film. Lens surface is fragile. Avoid rubbing or knocking it.

Replacement of Light Source Lamp

The light source lamp is a consumable item. Replace with a new lamp unit if the image appears dull or if the lamp burns out.

- When the lamp needs to be replaced soon, users will be notified through a message on the screen and the indicator. (☞ Page 53, 54)
- The life of the lamp used for this projector is about 2000 hours.
This is the average life of lamps, and not a guaranteed value.
- The lamp life may not reach 2000 hours depending on the operating conditions.
- Deterioration progresses rapidly when the remaining lamp usable time is short.
- If the image is dark or color tone abnormal, replace the lamp unit as soon as possible.
- For details on replacement of the lamp unit, please consult your authorized dealer.
- Lamp has to be replaced by an authorized person. Do not remove LAMP DOOR and lamp unit. This may cause fire and electric shock hazards. Access to the lamp unit only possible with use of tool.

Specifications

■ General

Power supply	AC 110 V to AC 240 V 50 Hz/60 Hz
Power consumption	1100 W (Standby mode: 6 W)
Current consumption	Max 9.5 A
Calorific power	3960 kJ/h (946 kcal/h)
Air capacity	Intake: Approx. 3 m ³ /min Exhaust: Approx. 3 m ³ /min
Allowable operating temperature range	10 °C to 35 °C
Allowable operating humidity range	Less than 80 % (no condensation)
Allowable storage temperature range	-5 °C to 60 °C
Installation height	Operation guarantee: 2000 m and below Performance guarantee: 1500 m and below
Dimensions	660 mm × 342 to 362 mm × 783 mm (Width × Height × Depth) (Excluding lens and small protrusions)
Mass	50.5 kg (Excluding lens)

■ Optical System

Projection method	D-ILA analog drive system × 3
D-ILA element ^{*1*2}	1.27" (4096 × 2400 pixels) × 3 pcs (total no. of pixels: 29,491,200 pixels)
Projection lens (optional)	GL-MS4015SZG (1.50:1 to 1.84:1 zoom lens) GL-MS4016SZG (1.50:1 to 1.84:1 zoom lens) GL-MS4021SZG (2.15:1 to 3.65:1 zoom lens) GL-MS4011SG (1:1.1 Short focal length lens)
Light-source Lamp	330 W high pressure mercury lamp
Screen size	80" to 300" (zoom lens) 50" to 250" (short focal length lens)
Projection distance	Approx. 2.6 m to 12 m (zoom lens) Approx. 1.2 m to 6 m (short focal length lens)

■ Terminal

Video input	DVI-D (dual link) 24 pins (supports 12-bit extended input) × 4 (supports HDCP ^{*3})
LAN	RJ45 × 1
USB	Type B (Slave) × 1
RS-232C	D-sub 9 pins (male) × 1

■ Optional Items

Projection lens	GL-MS4015SZG ● 1.50:1 to 1.84:1 1.22x zoom lens (80" to 300") GL-MS4016SZG ● 1.50:1 to 1.84:1 1.22x zoom lens (50" to 210") GL-MS4021SZG ● 2.15:1 to 3.65:1 1.69x zoom lens (80" to 300") GL-MS4011SG ● 1:1.1 short focal length lens (50" to 250")
Replacement filter/sponge (front)	LC43010-003A (Filter) LC43030-003A (Sponge)
Replacement sponge (right/left side)	LC43030-002A

*1 D-ILA is the abbreviation for Direct drive Image Light Amplifier.

*2 D-ILA devices are manufactured using extremely high-precision technology. Pixel effectiveness is 99.99 %. Only 0.01 % or less of the pixels would either not lit up or remain permanently lit up.

*3 HDCP is the abbreviation for High-bandwidth Digital Content Protection system. Images from the DVI input terminal may not be displayed due to HDCP specification changes.

- The open source software is embedded in this product. For more information, please go to: <http://www3.jvckenwood.com/english/download/lnx/07jvc-pj/>
- Specifications and appearance of this product may be subject to change for improvement without prior notice.
- Please note that some of the pictures and illustrations may have been abridged, enlarged or contextualized in order to aid comprehension. Images may differ from the actual product.

■ Pin Arrangement

● RS-232C Terminal

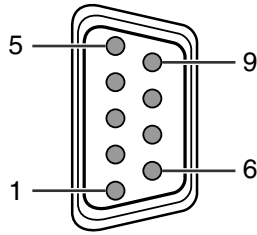

Pin No.	Signal	Action	Signal Direction
2	RxD	Incoming Data	This Projector ← PC
3	TxD	Outgoing Data	This Projector → PC
5	GND	Signal Ground	—
1, 4, 6–9	NC	—	—

● DVI-D Terminal

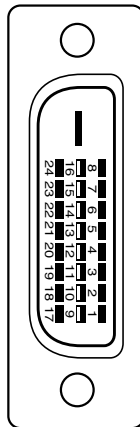

Pin No.	Signal	Pin No.	Signal
1	TMDS Data 2 –	13	TMDS Data 3+
2	TMDS Data 2+	14	TMDS +5 V Power Supply
3	TMDS Data 2/4 Shield	15	Earth (+5 V)
4	TMDS Data 4 –	16	Hot Plug Detection
5	TMDS Data 4+	17	TMDS Data 0 –
6	DDC Clock	18	TMDS Data 0+
7	DDC Data	19	TMDS Data 0/5 Shield
8	NC	20	TMDS Data 5 –
9	TMDS Data 1 –	21	TMDS Data 5+
10	TMDS Data 1+	22	TMDS Clock Shield
11	TMDS Data 1/3 Shield	23	TMDS Clock +
12	TMDS Data 3 –	24	TMDS Clock –

TMDS = Transition Minimized Differential Signaling
DDC = Display Data Channel

Specifications (Cont'd)

Dimensional Outline Drawing

(Unit: mm)

■ Top

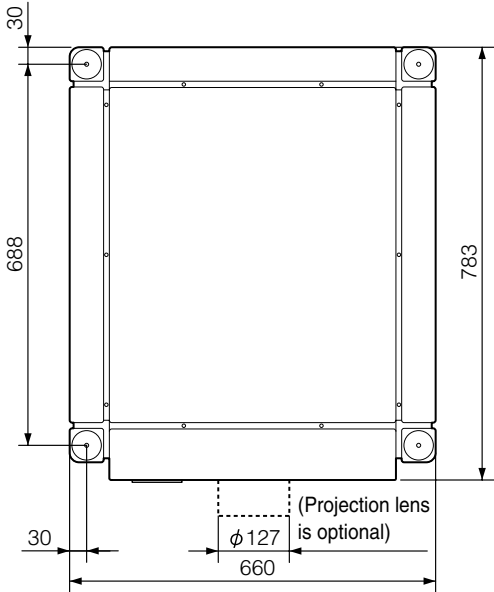

■ Side

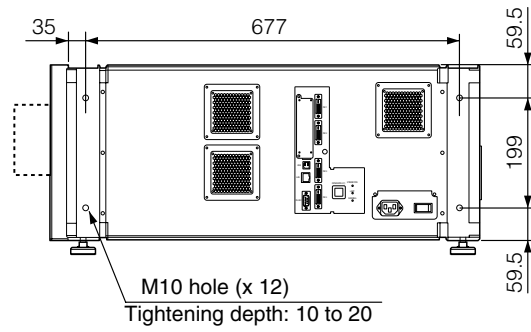

■ Front

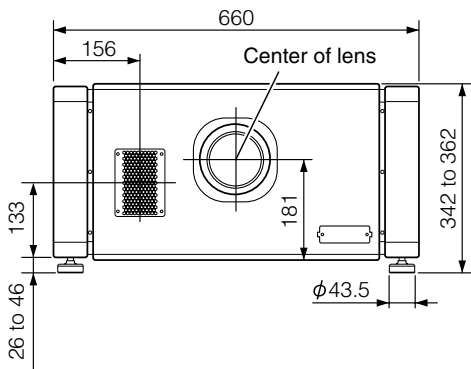

■ Rear

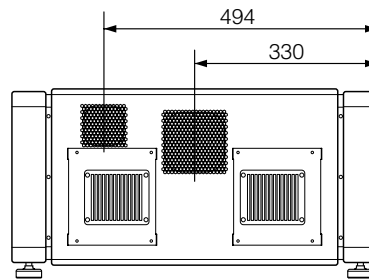

CAUTION:

- Using screws with dimensions other than those specified in the above diagram may cause the projector to drop or malfunction.

GNU GENERAL PUBLIC LICENSE

Version 2, June 1991

Copyright (C) 1989, 1991 Free Software Foundation, Inc.,
51 Franklin Street, Fifth Floor, Boston, MA 02110-1301 USA

Everyone is permitted to copy and distribute verbatim copies of this license document, but changing it is not allowed.

Preamble

The licenses for most software are designed to take away your freedom to share and change it. By contrast, the GNU General Public License is intended to guarantee your freedom to share and change free software--to make sure the software is free for all its users. This General Public License applies to most of the Free Software Foundation's software and to any other program whose authors commit to using it. (Some other Free Software Foundation software is covered by the GNU Lesser General Public License instead.) You can apply it to your programs, too.

When we speak of free software, we are referring to freedom, not price. Our General Public Licenses are designed to make sure that you have the freedom to distribute copies of free software (and charge for this service if you wish), that you receive source code or can get it if you want it, that you can change the software or use pieces of it in new free programs; and that you know you can do these things.

To protect your rights, we need to make restrictions that forbid anyone to deny you these rights or to ask you to surrender the rights. These restrictions translate to certain responsibilities for you if you distribute copies of the software, or if you modify it.

For example, if you distribute copies of such a program, whether gratis or for a fee, you must give the recipients all the rights that you have. You must make sure that they, too, receive or can get the source code. And you must show them these terms so they know their rights.

We protect your rights with two steps: (1) copyright the software, and (2) offer you this license which gives you legal permission to copy, distribute and/or modify the software.

Also, for each author's protection and ours, we want to make certain that everyone understands that there is no warranty for this free software. If the software is modified by someone else and passed on, we want its recipients to know that what they have is not the original, so that any problems introduced by others will not reflect on the original authors' reputations.

Finally, any free program is threatened constantly by software patents. We wish to avoid the danger that redistributors of a free program will individually obtain patent licenses, in effect making the program proprietary. To prevent this, we have made it clear that any patent must be licensed for everyone's free use or not licensed at all.

The precise terms and conditions for copying, distribution and modification follow.

GNU GENERAL PUBLIC LICENSE TERMS AND CONDITIONS FOR COPYING, DISTRIBUTION AND MODIFICATION

0. This License applies to any program or other work which contains a notice placed by the copyright holder saying it may be distributed under the terms of this General Public License. The "Program", below, refers to any such program or work, and a "work based on the Program" means either the Program or any derivative work under copyright law: that is to say, a work containing the Program or a portion of it, either verbatim or with modifications and/or translated into another language. (Hereinafter, translation is included without limitation in the term "modification".) Each licensee is addressed as "you".

Activities other than copying, distribution and modification are not covered by this License; they are outside its scope. The act of running the Program is not restricted, and the output from the Program is covered only if its contents constitute a work based on the Program (independent of having been made by running the Program). Whether that is true depends on what the Program does.

1. You may copy and distribute verbatim copies of the Program's source code as you receive it, in any medium, provided that you conspicuously and appropriately publish on each copy an appropriate copyright notice and disclaimer of warranty; keep intact all the notices that refer to this License and to the absence of any warranty; and give any other recipients of the Program a copy of this License along with the Program.

You may charge a fee for the physical act of transferring a copy, and you may at your option offer warranty protection in exchange for a fee.

2. You may modify your copy or copies of the Program or any portion of it, thus forming a work based on the Program, and copy and distribute such modifications or work under the terms of Section 1 above, provided that you also meet all of these conditions:

a) You must cause the modified files to carry prominent notices stating that you changed the files and the date of any change.

b) You must cause any work that you distribute or publish, that in whole or in part contains or is derived from the Program or any part thereof, to be licensed as a whole at no charge to all third parties under the terms of this License.

c) If the modified program normally reads commands interactively when run, you must cause it, when started running for such interactive use in the most ordinary way, to print or display an announcement including an appropriate copyright notice and a notice that there is no warranty (or else, saying that you provide a warranty) and that users may redistribute the program under these conditions, and telling the user how to view a copy of this License. (Exception: if the Program itself is interactive but does not normally print such an announcement, your work based on the Program is not required to print an announcement.)

These requirements apply to the modified work as a whole. If identifiable sections of that work are not derived from the Program, and can be reasonably considered independent and separate works in themselves, then this License, and its terms, do not apply to those sections when you distribute them as separate works. But when you distribute the same sections as part of a whole which is a work based on the Program, the distribution of the whole must be on the terms of this License, whose permissions for other licensees extend to the entire whole, and thus to each and every part regardless of who wrote it.

Thus, it is not the intent of this section to claim rights or contest your rights to work written entirely by you; rather, the intent is to exercise the right to control the distribution of derivative or collective works based on the Program.

In addition, mere aggregation of another work not based on the Program with the Program (or with a work based on the Program) on a volume of a storage or distribution medium does not bring the other work under the scope of this License.

3. You may copy and distribute the Program (or a work based on it, under Section 2) in object code or executable form under the terms of Sections 1 and 2 above provided that you also do one of the following:

a) Accompany it with the complete corresponding machine-readable source code, which must be distributed under the terms of Sections 1 and 2 above on a medium customarily used for software interchange; or,

b) Accompany it with a written offer, valid for at least three years, to give any third party, for a charge no more than your cost of physically performing source distribution, a complete machine-readable copy of the corresponding source code, to be distributed under the terms of Sections 1 and 2 above on a medium customarily used for software interchange; or,

c) Accompany it with the information you received as to the offer to distribute corresponding source code. (This alternative is allowed only for noncommercial distribution and only if you received the program in object code or executable form with such an offer, in accord with Subsection b above.)

The source code for a work means the preferred form of the work for making modifications to it. For an executable work, complete source code means all the source code for all modules it contains, plus any associated interface definition files, plus the scripts used to control compilation and installation of the executable. However, as a special exception, the source code distributed need not include anything that is normally distributed (in either source or binary form) with the major components (compiler, kernel, and so on) of the operating system on which the executable runs, unless that component itself accompanies the executable.

If distribution of executable or object code is made by offering access to copy from a designated place, then offering equivalent access to copy the source code from the same place counts as distribution of the source code, even though third parties are not compelled to copy the source along with the object code.

4. You may not copy, modify, sublicense, or distribute the Program except as expressly provided under this License. Any attempt otherwise to copy, modify, sublicense or distribute the Program is void, and will automatically terminate your rights under this License. However, parties who have received copies, or rights, from you under this License will not have their licenses terminated so long as such parties remain in full compliance.

5. You are not required to accept this License, since you have not signed it. However, nothing else grants you permission to modify or distribute the Program or its derivative works. These actions are prohibited by law if you do not accept this License. Therefore, by modifying or distributing the Program (or any work based on the Program), you indicate your acceptance of this License to do so, and all its terms and conditions for copying, distributing or modifying the Program or works based on it.

6. Each time you redistribute the Program (or any work based on the Program), the recipient automatically receives a license from the original licensor to copy, distribute or modify the Program subject to these terms and conditions. You may not impose any further restrictions on the recipients' exercise of the rights granted herein. You are not responsible for enforcing compliance by third parties to this License.

7. If, as a consequence of a court judgment or allegation of patent infringement or for any other reason (not limited to patent issues), conditions are imposed on you (whether by court order, agreement or otherwise) that contradict the conditions of this License, they do not excuse you from the conditions of this License. If you cannot distribute so as to satisfy simultaneously your obligations under this License and any other pertinent obligations, then as a consequence you may not distribute the Program at all. For example, if a patent license would not permit royalty-free redistribution of the Program by all those who receive copies directly or indirectly through you, then the only way you could satisfy both it and this License would be to refrain entirely from distribution of the Program.

If any portion of this section is held invalid or unenforceable under any particular circumstance, the balance of the section is intended to apply and the section as a whole is intended to apply in other circumstances.

It is not the purpose of this section to induce you to infringe any patents or other property right claims or to contest validity of any such claims; this section has the sole purpose of protecting the integrity of the free software distribution system, which is implemented by public license practices. Many people have made generous contributions to the wide range of software distributed through that system in reliance on consistent application of that system; it is up to the author/donor to decide if he or she is willing to distribute software through any other system and a licensee cannot impose that choice.

This section is intended to make thoroughly clear what is believed to be a consequence of the rest of this License.

8. If the distribution and/or use of the Program is restricted in certain countries either by patents or by copyrighted interfaces, the original copyright holder who places the Program under this License may add an explicit geographical distribution limitation excluding those countries, so that distribution is permitted only in or among countries not thus excluded. In such case, this License incorporates the limitation as if written in the body of this License.

9. The Free Software Foundation may publish revised and/or new versions of the General Public License from time to time. Such new versions will be similar in spirit to the present version, but may differ in detail to address new problems or concerns.

Each version is given a distinguishing version number. If the Program specifies a version number of this License which applies to it and "any later version", you have the option of following the terms and conditions either of that version or of any later version published by the Free Software Foundation. If the Program does not specify a version number of this License, you may choose any version ever published by the Free Software Foundation.

10. If you wish to incorporate parts of the Program into other free programs whose distribution conditions are different, write to the author to ask for permission. For software which is copyrighted by the Free Software Foundation, write to the Free Software Foundation; we sometimes make exceptions for this. Our decision will be guided by the two goals of preserving the free status of all derivatives of our free software and of promoting the sharing and reuse of software generally.

NO WARRANTY

11. BECAUSE THE PROGRAM IS LICENSED FREE OF CHARGE, THERE IS NO WARRANTY FOR THE PROGRAM, TO THE EXTENT PERMITTED BY APPLICABLE LAW. EXCEPT WHEN OTHERWISE STATED IN WRITING THE COPYRIGHT HOLDERS AND/OR OTHER PARTIES PROVIDE THE PROGRAM "AS IS" WITHOUT WARRANTY OF ANY KIND, EITHER EXPRESSED OR IMPLIED, INCLUDING, BUT NOT LIMITED TO, THE IMPLIED WARRANTIES OF MERCHANTABILITY AND FITNESS FOR A PARTICULAR PURPOSE. THE ENTIRE RISK AS TO THE QUALITY AND PERFORMANCE OF THE PROGRAM IS WITH YOU. SHOULD THE PROGRAM PROVE DEFECTIVE, YOU ASSUME THE COST OF ALL NECESSARY SERVICING, REPAIR OR CORRECTION.

12. IN NO EVENT UNLESS REQUIRED BY APPLICABLE LAW OR AGREED TO IN WRITING WILL ANY COPYRIGHT HOLDER, OR ANY OTHER PARTY WHO MAY MODIFY AND/OR REDISTRIBUTE THE PROGRAM AS PERMITTED ABOVE, BE LIABLE TO YOU FOR DAMAGES, INCLUDING ANY GENERAL, SPECIAL, INCIDENTAL OR CONSEQUENTIAL DAMAGES ARISING OUT OF THE USE OR INABILITY TO USE THE PROGRAM (INCLUDING BUT NOT LIMITED TO LOSS OF DATA OR DATA BEING RENDERED INACCURATE OR LOSSES SUSTAINED BY YOU OR THIRD PARTIES OR A FAILURE OF THE PROGRAM TO OPERATE WITH ANY OTHER PROGRAMS), EVEN IF SUCH HOLDER OR OTHER PARTY HAS BEEN ADVISED OF THE POSSIBILITY OF SUCH DAMAGES.

END OF TERMS AND CONDITIONS

How to Apply These Terms to Your New Programs

If you develop a new program, and you want it to be of the greatest possible use to the public, the best way to achieve this is to make it free software which everyone can redistribute and change under these terms.

To do so, attach the following notices to the program. It is safest to attach them to the start of each source file to most effectively convey the exclusion of warranty; and each file should have at least the "copyright" line and a pointer to where the full notice is found.

<one line to give the program's name and a brief idea of what it does.>

Copyright (C) <year> <name of author>

This program is free software; you can redistribute it and/or modify it under the terms of the GNU General Public License as published by the Free Software Foundation; either version 2 of the License, or (at your option) any later version.

This program is distributed in the hope that it will be useful, but WITHOUT ANY WARRANTY; without even the implied warranty of MERCHANTABILITY or FITNESS FOR A PARTICULAR PURPOSE. See the GNU General Public License for more details.

You should have received a copy of the GNU General Public License along with this program; if not, write to the Free Software Foundation, Inc., 51 Franklin Street, Fifth Floor, Boston, MA 02110-1301 USA.

Also add information on how to contact you by electronic and paper mail.

If the program is interactive, make it output a short notice like this when it starts in an interactive mode:

Gnomovision version 69, Copyright (C) year name of author
Gnomovision comes with ABSOLUTELY NO WARRANTY; for details type `show w'.

This is free software, and you are welcome to redistribute it under certain conditions; type `show c' for details.

The hypothetical commands `show w' and `show c' should show the appropriate parts of the General Public License. Of course, the commands you use may be called something other than `show w' and `show c'; they could even be mouse-clicks or menu items--whatever suits your program.

You should also get your employer (if you work as a programmer) or your school, if any, to sign a "copyright disclaimer" for the program, if necessary. Here is a sample; alter the names:

Yoyodyne, Inc., hereby disclaims all copyright interest in the program `Gnomovision' (which makes passes at compilers) written by James Hacker.

<signature of Ty Coon>, 1 April 1989
Ty Coon, President of Vice

This General Public License does not permit incorporating your program into proprietary programs. If your program is a subroutine library, you may consider it more useful to permit linking proprietary applications with the library. If this is what you want to do, use the GNU Lesser General Public License instead of this License.

GNU LESSER GENERAL PUBLIC LICENSE

Version 2.1, February 1999

Copyright (C) 1991, 1999 Free Software Foundation, Inc.,
51 Franklin Street, Fifth Floor, Boston, MA 02110-1301
USA

Everyone is permitted to copy and distribute verbatim copies of this license document, but changing it is not allowed.

[This is the first released version of the Lesser GPL. It also counts as the successor of the GNU Library Public License, version 2, hence the version number 2.1.]

Preamble

The licenses for most software are designed to take away your freedom to share and change it. By contrast, the GNU General Public Licenses are intended to guarantee your freedom to share and change free software--to make sure the software is free for all its users.

This license, the Lesser General Public License, applies to some specially designated software packages--typically libraries--of the Free Software Foundation and other authors who decide to use it. You can use it too, but we suggest you first think carefully about whether this license or the ordinary General Public License is the better strategy to use in any particular case, based on the explanations below.

When we speak of free software, we are referring to freedom of use, not price. Our General Public Licenses are designed to make sure that you have the freedom to distribute copies of free software (and charge for this service if you wish); that you receive source code or can get it if you want it; that you can change the software and use pieces of it in new free programs; and that you are informed that you can do these things.

To protect your rights, we need to make restrictions that forbid distributors to deny you these rights or to ask you to surrender these rights. These restrictions translate to certain responsibilities for you if you distribute copies of the library or if you modify it.

For example, if you distribute copies of the library, whether gratis or for a fee, you must give the recipients all the rights that we gave you. You must make sure that they, too, receive or can get the source code. If you link other code with the library, you must provide complete object files to the recipients, so that they can relink them with the library after making changes to the library and recompiling it. And you must show them these terms so they know their rights.

We protect your rights with a two-step method: (1) we copyright the library, and (2) we offer you this license, which gives you legal permission to copy, distribute and/or modify the library.

To protect each distributor, we want to make it very clear that there is no warranty for the free library. Also, if the library is modified by someone else and passed on, the recipients should know that what they have is not the original version, so that the original author's reputation will not be affected by problems that might be introduced by others.

Finally, software patents pose a constant threat to the existence of any free program. We wish to make sure that a company cannot effectively restrict the users of a free program by obtaining a restrictive license from a patent holder. Therefore, we insist that any patent license obtained for a version of the library must be consistent with the full freedom of use specified in this license.

Most GNU software, including some libraries, is covered by the ordinary GNU General Public License. This license, the GNU Lesser General Public License, applies to certain designated libraries, and is quite different from the ordinary General Public License. We use this license for certain libraries in order to permit linking those libraries into non-free programs.

When a program is linked with a library, whether statically or using a shared library, the combination of the two is legally speaking a combined work, a derivative of the original library. The ordinary General Public License therefore permits such linking only if the entire combination fits its criteria of freedom. The Lesser General Public License permits more lax criteria for linking other code with the library.

We call this license the "Lesser" General Public License because it does Less to protect the user's freedom than the ordinary General Public License. It also provides other free software developers Less of an advantage over competing non-free programs. These disadvantages are the reason we use the ordinary General Public License for many libraries. However, the Lesser license provides advantages in certain special circumstances.

For example, on rare occasions, there may be a special need to encourage the widest possible use of a certain library, so that it becomes a de-facto standard. To achieve this, non-free programs must be allowed to use the library. A more frequent case is that a free library does the same job as widely used non-free libraries. In this case, there is little to gain by limiting the free library to free software only, so we use the Lesser General Public License.

In other cases, permission to use a particular library in non-free programs enables a greater number of people to use a large body of free software. For example, permission to use the GNU C Library in non-free programs enables many more people to use the whole GNU operating system, as well as its variant, the GNU/Linux operating system.

Although the Lesser General Public License is Less protective of the users' freedom, it does ensure that the user of a program that is linked with the Library has the freedom and the wherewithal to run that program using a modified version of the Library.

The precise terms and conditions for copying, distribution and modification follow. Pay close attention to the difference between a "work based on the library" and a "work that uses the library". The former contains code derived from the library, whereas the latter must be combined with the library in order to run.

GNU LESSER GENERAL PUBLIC LICENSE TERMS AND CONDITIONS FOR COPYING, DISTRIBUTION AND MODIFICATION

0. This License Agreement applies to any software library or other program which contains a notice placed by the copyright holder or other authorized party saying it may be distributed under the terms of this Lesser General Public License (also called "this License"). Each licensee is addressed as "you".

A "library" means a collection of software functions and/or data prepared so as to be conveniently linked with application programs (which use some of those functions and data) to form executables.

The "Library", below, refers to any such software library or work which has been distributed under these terms. A "work based on the Library" means either the Library or any derivative work under copyright law: that is to say, a work containing the Library or a portion of it, either verbatim or with modifications and/or translated straightforwardly into another language. (Hereinafter, translation is included without limitation in the term "modification".)

"Source code" for a work means the preferred form of the work for making modifications to it. For a library, complete source code means all the source code for all modules it contains, plus any associated interface definition files, plus the scripts used to control compilation and installation of the library.

Activities other than copying, distribution and modification are not covered by this License; they are outside its scope. The act of running a program using the Library is not restricted, and output from such a program is covered only if its contents constitute a work based on the Library (independent of the use of the Library in a tool for writing it). Whether that is true depends on what the Library does and what the program that uses the Library does.

1. You may copy and distribute verbatim copies of the Library's complete source code as you receive it, in any medium, provided that you conspicuously and appropriately publish on each copy an appropriate copyright notice and disclaimer of warranty; keep intact all the notices that refer to this License and to the absence of any warranty; and distribute a copy of this License along with the Library.

You may charge a fee for the physical act of transferring a copy, and you may at your option offer warranty protection in exchange for a fee.

2. You may modify your copy or copies of the Library or any portion of it, thus forming a work based on the Library, and copy and distribute such modifications or work under the terms of Section 1 above, provided that you also meet all of these conditions:

a) The modified work must itself be a software library.

b) You must cause the files modified to carry prominent notices stating that you changed the files and the date of any change.

c) You must cause the whole of the work to be licensed at no charge to all third parties under the terms of this License.

d) If a facility in the modified Library refers to a function or a table of data to be supplied by an application program that uses the facility, other than as an argument passed when the facility is invoked, then you must make a good faith effort to ensure that, in the event an application does not supply such function or table, the facility still operates, and performs whatever part of its purpose remains meaningful.

(For example, a function in a library to compute square roots has a purpose that is entirely well-defined independent of the application. Therefore, Subsection 2d requires that any application-supplied function or table used by this function must be optional: if the application does not supply it, the square root function must still compute square roots.)

These requirements apply to the modified work as a whole. If identifiable sections of that work are not derived from the Library, and can be reasonably considered independent and separate works in themselves, then this License, and its terms, do not apply to those sections when you distribute them as separate works. But when you distribute the same sections as part of a whole which is a work based on the Library, the distribution of the whole must be on the terms of this License, whose permissions for other licensees extend to the entire whole, and thus to each and every part regardless of who wrote it.

Thus, it is not the intent of this section to claim rights or contest your rights to work written entirely by you; rather, the intent is to exercise the right to control the distribution of derivative or collective works based on the Library.

In addition, mere aggregation of another work not based on the Library with the Library (or with a work based on the Library) on a volume of a storage or distribution medium does not bring the other work under the scope of this License.

3. You may opt to apply the terms of the ordinary GNU General Public License instead of this License to a given copy of the Library. To do this, you must alter all the notices that refer to this License, so that they refer to the ordinary GNU General Public License, version 2, instead of to this License. (If a newer version than version 2 of the ordinary GNU General Public License has appeared, then you can specify that version instead if you wish.) Do not make any other change in these notices.

Once this change is made in a given copy, it is irreversible for that copy, so the ordinary GNU General Public License applies to all subsequent copies and derivative works made from that copy.

This option is useful when you wish to copy part of the code of the Library into a program that is not a library.

4. You may copy and distribute the Library (or a portion or derivative of it, under Section 2) in object code or executable form under the terms of Sections 1 and 2 above provided that you accompany it with the complete corresponding machine-readable source code, which must be distributed under the terms of Sections 1 and 2 above on a medium customarily used for software interchange.

If distribution of object code is made by offering access to copy from a designated place, then offering equivalent access to copy the source code from the same place satisfies the requirement to distribute the source code, even though third parties are not compelled to copy the source along with the object code.

5. A program that contains no derivative of any portion of the Library, but is designed to work with the Library by being compiled or linked with it, is called a "work that uses the Library". Such a work, in isolation, is not a derivative work of the Library, and therefore falls outside the scope of this License.

However, linking a "work that uses the Library" with the Library creates an executable that is a derivative of the Library (because it contains portions of the Library), rather than a "work that uses the library". The executable is therefore covered by this License. Section 6 states terms for distribution of such executables.

When a "work that uses the Library" uses material from a header file that is part of the Library, the object code for the work may be a derivative work of the Library even though the source code is not. Whether this is true is especially significant if the work can be linked without the Library, or if the work is itself a library. The threshold for this to be true is not precisely defined by law.

If such an object file uses only numerical parameters, data structure layouts and accessors, and small macros and small inline functions (ten lines or less in length), then the use of the object file is unrestricted, regardless of whether it is legally a derivative work. (Executables containing this object code plus portions of the Library will still fall under Section 6.)

Otherwise, if the work is a derivative of the Library, you may distribute the object code for the work under the terms of Section 6. Any executables containing that work also fall under Section 6, whether or not they are linked directly with the Library itself.

6. As an exception to the Sections above, you may also combine or link a "work that uses the Library" with the Library to produce a work containing portions of the Library, and distribute that work under terms of your choice, provided that the terms permit modification of the work for the customer's own use and reverse engineering for debugging such modifications.

You must give prominent notice with each copy of the work that the Library is used in it and that the Library and its use are covered by this License. You must supply a copy of this License. If the work during execution displays copyright notices, you must include the copyright notice for the Library among them, as well as a reference directing the user to the copy of this License. Also, you must do one of these things:

a) Accompany the work with the complete corresponding machine-readable source code for the Library including whatever changes were used in the work (which must be distributed under Sections 1 and 2 above); and, if the work is an executable linked with the Library, with the complete machine-readable "work that uses the Library", as object code and/or source code, so that the user can modify the Library and then relink to produce a modified executable containing the modified Library. (It is understood that the user who changes the contents of definitions files in the Library will not necessarily be able to recompile the application to use the modified definitions.)

b) Use a suitable shared library mechanism for linking with the Library. A suitable mechanism is one that (1) uses at run time a copy of the library already present on the user's computer system, rather than copying library functions into the executable, and (2) will operate properly with a modified version of the library, if the user installs one, as long as the modified version is interface-compatible with the version that the work was made with.

c) Accompany the work with a written offer, valid for at least three years, to give the same user the materials specified in Subsection 6a, above, for a charge no more than the cost of performing this distribution.

d) If distribution of the work is made by offering access to copy from a designated place, offer equivalent access to copy the above specified materials from the same place.

e) Verify that the user has already received a copy of these materials or that you have already sent this user a copy.

For an executable, the required form of the "work that uses the Library" must include any data and utility programs needed for reproducing the executable from it. However, as a special exception, the materials to be distributed need not include anything that is normally distributed (in either source or binary form) with the major components (compiler, kernel, and so on) of the operating system on which the executable runs, unless that component itself accompanies the executable.

It may happen that this requirement contradicts the license restrictions of other proprietary libraries that do not normally accompany the operating system. Such a contradiction means you cannot use both them and the Library together in an executable that you distribute.

7. You may place library facilities that are a work based on the Library side-by-side in a single library together with other library facilities not covered by this License, and distribute such a combined library, provided that the separate distribution of the work based on the Library and of the other library facilities is otherwise permitted, and provided that you do these two things:

a) Accompany the combined library with a copy of the same work based on the Library, uncombined with any other library facilities. This must be distributed under the terms of the Sections above.

b) Give prominent notice with the combined library of the fact that part of it is a work based on the Library, and explaining where to find the accompanying uncombined form of the same work.

8. You may not copy, modify, sublicense, link with, or distribute the Library except as expressly provided under this License. Any attempt otherwise to copy, modify, sublicense, link with, or distribute the Library is void, and will automatically terminate your rights under this License. However, parties who have received copies, or rights, from you under this License will not have their licenses terminated so long as such parties remain in full compliance.

9. You are not required to accept this License, since you have not signed it. However, nothing else grants you permission to modify or distribute the Library or its derivative works. These actions are prohibited by law if you do not accept this License. Therefore, by modifying or distributing the Library (or any work based on the Library), you indicate your acceptance of this License to do so, and all its terms and conditions for copying, distributing or modifying the Library or works based on it.

10. Each time you redistribute the Library (or any work based on the Library), the recipient automatically receives a license from the original licensor to copy, distribute, link with or modify the Library subject to these terms and conditions. You may not impose any further restrictions on the recipients' exercise of the rights granted herein. You are not responsible for enforcing compliance by third parties with this License.

11. If, as a consequence of a court judgment or allegation of patent infringement or for any other reason (not limited to patent issues), conditions are imposed on you (whether by court order, agreement or otherwise) that contradict the conditions of this License, they do not excuse you from the conditions of this License. If you cannot distribute so as to satisfy simultaneously your obligations under this License and any other pertinent obligations, then as a consequence you may not distribute the Library at all. For example, if a patent license would not permit royalty-free redistribution of the Library by all those who receive copies directly or indirectly through you, then the only way you could satisfy both it and this License would be to refrain entirely from distribution of the Library.

If any portion of this section is held invalid or unenforceable under any particular circumstance, the balance of the section is intended to apply, and the section as a whole is intended to apply in other circumstances.

It is not the purpose of this section to induce you to infringe any patents or other property right claims or to contest validity of any such claims; this section has the sole purpose of protecting the integrity of the free software distribution system which is implemented by public license practices. Many people have made generous contributions to the wide range of software distributed through that system in reliance on consistent application of that system; it is up to the author/donor to decide if he or she is willing to distribute software through any other system and a licensee cannot impose that choice.

This section is intended to make thoroughly clear what is believed to be a consequence of the rest of this License.

12. If the distribution and/or use of the Library is restricted in certain countries either by patents or by copyrighted interfaces, the original copyright holder who places the Library under this License may add an explicit geographical distribution limitation excluding those countries, so that distribution is permitted only in or among countries not thus excluded. In such case, this License incorporates the limitation as if written in the body of this License.

13. The Free Software Foundation may publish revised and/or new versions of the Lesser General Public License from time to time. Such new versions will be similar in spirit to the present version, but may differ in detail to address new problems or concerns.

Each version is given a distinguishing version number. If the Library specifies a version number of this License which applies to it and "any later version", you have the option of following the terms and conditions either of that version or of any later version published by the Free Software Foundation. If the Library does not specify a license version number, you may choose any version ever published by the Free Software Foundation.

14. If you wish to incorporate parts of the Library into other free programs whose distribution conditions are incompatible with these, write to the author to ask for permission. For software which is copyrighted by the Free Software Foundation, write to the Free Software Foundation; we sometimes make exceptions for this. Our decision will be guided by the two goals of preserving the free status of all derivatives of our free software and of promoting the sharing and reuse of software generally.

NO WARRANTY

15. BECAUSE THE LIBRARY IS LICENSED FREE OF CHARGE, THERE IS NO WARRANTY FOR THE LIBRARY, TO THE EXTENT PERMITTED BY APPLICABLE LAW.

EXCEPT WHEN OTHERWISE STATED IN WRITING THE COPYRIGHT HOLDERS AND/OR OTHER PARTIES PROVIDE THE LIBRARY "AS IS" WITHOUT WARRANTY OF ANY KIND, EITHER EXPRESSED OR IMPLIED, INCLUDING, BUT NOT LIMITED TO, THE IMPLIED WARRANTIES OF MERCHANTABILITY AND FITNESS FOR A PARTICULAR PURPOSE. THE ENTIRE RISK AS TO THE QUALITY AND PERFORMANCE OF THE LIBRARY IS WITH YOU. SHOULD THE LIBRARY PROVE DEFECTIVE, YOU ASSUME THE COST OF ALL NECESSARY SERVICING, REPAIR OR CORRECTION.

16. IN NO EVENT UNLESS REQUIRED BY APPLICABLE LAW OR AGREED TO IN WRITING WILL ANY COPYRIGHT HOLDER, OR ANY OTHER PARTY WHO MAY MODIFY AND/OR REDISTRIBUTE THE LIBRARY AS PERMITTED ABOVE, BE LIABLE TO YOU FOR DAMAGES, INCLUDING ANY GENERAL, SPECIAL, INCIDENTAL OR CONSEQUENTIAL DAMAGES ARISING OUT OF THE USE OR INABILITY TO USE THE LIBRARY (INCLUDING BUT NOT LIMITED TO LOSS OF DATA OR DATA BEING RENDERED INACCURATE OR LOSSES SUSTAINED BY YOU OR THIRD PARTIES OR A FAILURE OF THE LIBRARY TO OPERATE WITH ANY OTHER SOFTWARE), EVEN IF SUCH HOLDER OR OTHER PARTY HAS BEEN ADVISED OF THE POSSIBILITY OF SUCH DAMAGES.

END OF TERMS AND CONDITIONS

How to Apply These Terms to Your New Libraries

If you develop a new library, and you want it to be of the greatest possible use to the public, we recommend making it free software that everyone can redistribute and change. You can do so by permitting redistribution under these terms (or, alternatively, under the terms of the ordinary General Public License).

To apply these terms, attach the following notices to the library. It is safest to attach them to the start of each source file to most effectively convey the exclusion of warranty; and each file should have at least the "copyright" line and a pointer to where the full notice is found.

<one line to give the library's name and a brief idea of what it does.>

Copyright (C) <year> <name of author>

This library is free software; you can redistribute it and/or modify it under the terms of the GNU Lesser General Public License as published by the Free Software Foundation; either version 2.1 of the License, or (at your option) any later version.

This library is distributed in the hope that it will be useful, but WITHOUT ANY WARRANTY; without even the implied warranty of MERCHANTABILITY or FITNESS FOR A PARTICULAR PURPOSE. See the GNU Lesser General Public License for more details.

You should have received a copy of the GNU Lesser General Public License along with this library; if not, write to the Free Software Foundation, Inc., 51 Franklin Street, Fifth Floor, Boston, MA 02110-1301 USA

Also add information on how to contact you by electronic and paper mail.

You should also get your employer (if you work as a programmer) or your school, if any, to sign a "copyright disclaimer" for the library, if necessary. Here is a sample; alter the names:

Yoyodyne, Inc., hereby disclaims all copyright interest in the library `Frob' (a library for tweaking knobs) written by James Random Hacker.

<signature of Ty Coon>, 1 April 1990
Ty Coon, President of Vice

That's all there is to it!

INFORMATION Manufacturer:

JVC KENWOOD Corporation
3-12, Moriya-cho, Kanagawa-ku, Yokohama-shi,
Kanagawa, 221-0022, JAPAN

Importer (EU only):

JVC KENWOOD U.K. Limited
12 Priestley Way, London, NW2 7BA
UNITED KINGDOM

For more details, please refer to our website.
<http://www3.jvckenwood.com/projector/support/index.html>

Memo :

DLA-SH7NL **D-LILA** PROJECTOR

JVC