

JVC

MULTI FORMAT LCD MONITOR

DT-E15L4

INSTRUCTIONS

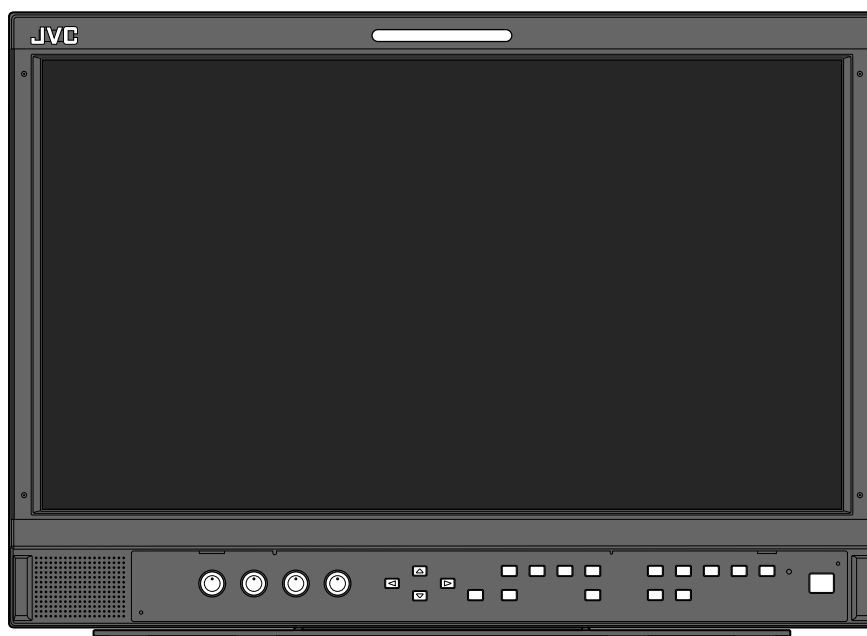



This is the English instruction manual.

Instruction manuals in other languages (German, French, Italian, Spanish, Russian, Chinese) are included on the supplied CD-ROM as PDF files.

HDMI[®]
HIGH-DEFINITION MULTIMEDIA INTERFACE

LCT2710-001A

Safety Precautions

 <div style="border: 1px solid black; padding: 5px; text-align: center;"> <p>CAUTION</p> <p>RISK OF ELECTRICAL SHOCK</p> <p>DO NOT OPEN</p> </div> 	<p>The lightning flash with arrowhead symbol, within an equilateral triangle is intended to alert the user to the presence of uninsulated "dangerous voltage" within the product's enclosure that may be of sufficient magnitude to constitute a risk of electric shock to persons.</p>
<p>CAUTION: To reduce the risk of electric shock. Do not remove cover (or back). No user serviceable parts inside. Refer servicing to qualified service personnel.</p>	<p>The exclamation point within an equilateral triangle is intended to alert the user to the presence of important operating and maintenance (servicing) instructions in the literature accompanying the appliance.</p>

WARNING: TO REDUCE RISK OF FIRE OR ELECTRIC SHOCK, DO NOT EXPOSE THIS APPARATUS TO RAIN OR MOISTURE. NO OBJECTS FILLED WITH LIQUIDS, SUCH AS VASES, SHALL BE PLACED ON THE APPARATUS.

Warning: This is a class A product. In a domestic environment this product may cause radio interference in which case the user may be required to take adequate measures.

IMPORTANT SAFEGUARDS

Electrical energy can perform many useful functions. This unit has been engineered and manufactured to assure your personal safety. But **IMPROPER USE CAN RESULT IN POTENTIAL ELECTRIC SHOCK OR FIRE**. In order not to defeat the safeguards incorporated into this product, observe the following basic rules for its installation, use, and service. Please read these "IMPORTANT SAFEGUARDS" carefully before use.

- All the safety and operating instructions should be read before the product is operated.
- The safety and operating instructions should be retained for future reference.
- All warnings on the product and in the operating instructions should be adhered to.
- All operating instructions should be followed.

POWER CONNECTION

The power supply voltage rating of this product is AC 120 V (For U.S.A. and Canada) and AC 220 – 240 V (For European countries, Asian countries, and United Kingdom).

The power cord attached conforms to the following power supply voltage and countries. Use only the power cord designated to ensure safety and EMC regulations of each country.

- Not all types of power cords are supplied to this product.

For U.S.A. and Canada: AC 120 V	For European and Asian countries: AC 220 – 240 V	For United Kingdom: AC 220 – 240 V
------------------------------------	---	---------------------------------------

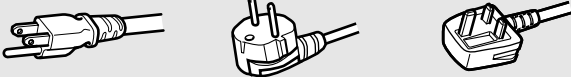

This plug will fit only into a grounded power outlet. If you are unable to insert the plug into the outlet, contact your electrician to install the proper outlet. Do not defeat the safety purpose of the grounded plug.

- This product should be operated only with the type of power source indicated on the label. If you are not sure of the type of power supply of your home, consult your product dealer or local electric power company.

Warning:

- Do not use the same power cord for AC 120 V as for AC 220 – 240 V. Doing so may cause malfunction, electric shock or fire.

Note for United Kingdom power cord only

The plug of United Kingdom power cord has a built-in fuse. When replacing the fuse, be sure to use only a correctly rated approved type, re-fit the fuse cover. (Consult your dealer or qualified personnel.)

How to replace the fuse

Open the fuse compartment with the blade screwdriver, and replace the fuse.

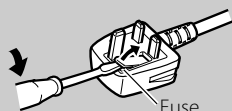

- Before connecting other products such as VCR's and personal computers, you should turn off the power of this product for protection against electric shock.
- Do not use attachments not recommended by the manufacturer as they may be hazardous.
- **When replacement parts are required**, be sure the service technician has used replacement parts specified by the manufacturer or equivalents. Unauthorized substitutions may result in fire, electric shock, or other hazards.
- **Upon completion of any service or repairs to this product**, ask the service technician to perform safety checks to determine that the product is in proper operating condition.

- Do not install this product in the following places:
 - in a damp or dusty room
 - where the product is exposed to soot or steam, such as near the cooking counter or a humidifier
 - near heat sources
 - where condensation easily occurs, such as near the window
 - in a location exposed to direct sunlight or strong light
- Do not place this product on an unstable cart, stand, or table. The product may fall, causing serious injury to a child or adult, and serious damage to the product. The product should be mounted according to the manufacturer's instructions, and should use a mount recommended by the manufacturer.
- Do not use this product near water.
- Be sure to install the product in the place where proper temperature and humidity are kept (see "Operating conditions" on page 45). This product becomes hot during its use. Take enough care when handling the product.

Under the following conditions,

1. Turn off the power.
2. Unplug this product from the wall outlet.
3. Refer service to qualified service personnel.
 - a) When the product emits smoke or unusual smell.
 - b) When the product exhibits a distinct change in performance —for example, no picture or no sound.
 - c) If liquid has been spilled, or objects have fallen on the product.
 - d) If the product has been exposed to rain or water.
 - e) If the product has been dropped or damaged in any way.
 - f) When the power supply cord or plug is damaged.

Do not attempt to service this product yourself, as opening or removing covers may expose you to dangerous voltages and other hazards. Refer all service to qualified service personnel.

Do not use the product for a long time if the sound is distorted.

Use only the power source specified on the unit.
• AC power: 120 V/220 - 240 V, 50 Hz/60 Hz

- The AC power supply is controlled by turning on/off the POWER switch on the rear panel. If the product is installed in a place where you cannot easily turn on/off the POWER switch, control the AC power supply by plugging/unplugging the power cord into/from the AC outlet. In this case, install the product as close to the AC outlet as possible, and leave enough space for plugging/unplugging the power cord. If the product is installed in a place where you cannot easily plug/unplug the power cord, equip an easily accessible device to the wiring of the building for turning on/off the power.
- When the product is left unattended and unused for a long period of time, unplug it from the wall outlet and disconnect the cable system.
- Do not overload wall outlets, extension cords, or convenience receptacles on other equipment as this can result in a risk of fire or electric shock.
- Use only the accessory cord designed for this product to prevent shock.

- Slots and openings in the cabinet are provided for ventilation. These ensure reliable operation of the product and protect it from overheating. These openings must not be blocked or covered.
- Never push objects of any kind into this product through openings as they may touch dangerous voltage points or short-circuit the parts, which could result in a fire or electric shock.
- Never spill liquid of any kind on the product.
- Never place anything on the product. (Placing liquids, naked flames, cloths, paper, etc. on the product may cause a fire.)
- Do not apply any strong shock to the LCD panel. (Do not hit any object against it or push it with a sharp-pointed tool.)
- Do not put heavy objects on the product.
- Do not step on or hang on the product.

WARNING

To prevent injury by accidental fall

Fix the monitor to a wall by using strings.

Fixing the monitor

Attach the hook (not provided) to the VESA mounting holes on the rear panel (use the two holes on the upper side) using M4 x 10 mm screws (not provided). Bind the hooks on the rear panel of the monitor to a wall or a pillar using durable string.

VESA mounting holes

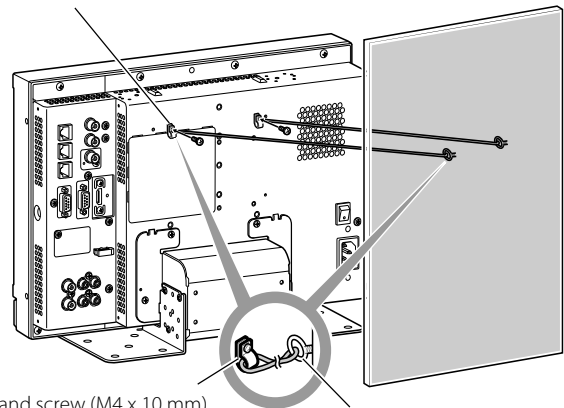

Hook and screw (M4 x 10 mm)
(not provided)

Hook (not provided)

Safety Precautions (cont.)

European Union only

Dear Customer,

This apparatus is in conformance with the valid European directives and standards regarding electromagnetic compatibility and electrical safety.

European representative of JVC KENWOOD Corporation is:

JVC Technical Services Europe GmbH

Postfach 10 05 04

61145 Friedberg

Germany

Information for Users on Disposal of Old Equipment



[European Union]

This symbol indicates that the electrical and electronic equipment should not be disposed of as general household waste at its end-of-life. Instead, the product should be handed over to the applicable collection point for the recycling of electrical and electronic equipment for proper treatment, recovery and recycling in accordance with your national legislation.

Attention:

This symbol is only valid in the European Union.

By disposing of this product correctly, you will help to conserve natural resources and will help prevent potential negative effects on the environment and human health which could otherwise be caused by inappropriate waste

handling of this product. For more information about collection point and recycling of this product, please contact your local municipal office, your household waste disposal service or the shop where you purchased the product.

Penalties may be applicable for incorrect disposal of this waste, in accordance with national legislation.

(Business users)

If you wish to dispose of this product, please visit our web page <http://www.jvc.eu/> to obtain information about the take-back of the product.

[Other Countries outside the European Union]

If you wish to dispose of this product, please do so in accordance with applicable national legislation or other rules in your country for the treatment of old electrical and electronic equipment.

EMC Supplement

This equipment is in conformity with the provisions and protection requirements of the corresponding European Directives. This equipment is designed for professional video appliances and can be used in the following environments:

- Controlled EMC environment (for example purpose built broadcasting or recording studio), and rural outdoors environment (far away from railways, transmitters, overhead power lines, etc.)
- In order to keep the best performance and ensure electromagnetic compatibility, we recommend to use cables not exceeding the following length:

Cable	Length
Power cord (attached cable (H05VV-F 3 x 0.75 mm ²))	2.0 m
Video signal cable (coaxial cable)	2.0 m
Audio signal cable (shielded cable)	1.5 m
HDMI cable (shielded cable)	2.0 m
DVI cable (shielded cable) with core filter	2.0 m
RS-232C cable (shielded cable) (A straight cable with a D-sub 9-pin connector)	2.0 m
RS-485 cable (twist pair cable) (A straight LAN cable)	2.0 m
REMOTE cable (twist pair cable) (A straight LAN cable)	2.0 m
RGB VGA cable (shielded cable)	2.0 m

The inrush current of this apparatus is 4.24 ampere.

CAUTION

In case where the strong electromagnetic waves or magnetism are near the audio cable or the signal cable, the sound or the picture will contain noise. In such cases, please keep the cable away from the sources of the disturbance.

Sicherheitsmaßregeln



CAUTION
RISK OF ELECTRICAL SHOCK
DO NOT OPEN



VORSICHT: Zur Verhinderung von elektrischen Schlägen. Keine Abdeckungen (oder Rückplatten) entfernen. Im Inneren befinden sich keine vom Anwender zu wartenden Teile. Wartungsarbeiten müssen qualifiziertem Fachpersonal überlassen werden.



Das Blitzsymbol in einem gleichseitigen Dreieck weist auf das Vorhandensein von nicht isolierten Teilen mit „gefährlicher Spannung“ innerhalb des Gehäuses hin, die bei unvorsichtigen Eingriffen zu elektrischen Schlägen führen können.



Das Ausrufezeichen in einem gleichseitigen Dreieck soll den Anwender darauf hinweisen, dass wichtige Betriebs- und Wartungs- (Service-) Anweisungen in der dem Gerät beiliegenden Dokumentation vorhanden sind.

WARNUNG: UM DIE GEFAHR VON BRÄNDEN ODER ELEKTRISCHEN SCHLÄGEN ZU VERMEIDEN, DIESES GERÄT NICHT REGEN ODER FEUCHTIGKEIT AUSSETZEN. ES DÜRFEN KEINE MIT FLÜSSIGKEIT GEFÜLLTEN BEHÄLTER WIE ETWA VASEN AUF DAS GERÄT GESTELLT WERDEN.

Achtung: Dies ist ein Klasse-A-Produkt. In nichtgewerblichen Umgebungen können von dem Gerät Funkstörungen ausgehen, zu deren Beseitigung vom Benutzer geeignete Maßnahmen zu ergreifen sind.

WICHTIGE SCHUTZMASSNAHMEN

Elektrische Energie kann für viele nützliche Zwecke eingesetzt werden. Dieses Gerät wurde im Hinblick auf höchste Betriebssicherheit konstruiert und hergestellt. Aber **FALSCHER VERWENDUNG KANN EINEN BRAND ODER ELEKTRISCHEN SCHLAG VERURSACHEN**. Um nicht die in diesem Gerät eingebauten Schutzvorrichtungen zu unterdrücken, müssen Sie immer die folgenden grundlegenden Regeln für Aufstellung, Betrieb und Wartung befolgen. Bitte lesen Sie die Angaben unter „WICHTIGE SCHUTZMASSNAHMEN“ sorgfältig vor dem Gebrauch durch.

- Alle Sicherheits- und Bedienungsanweisungen müssen vor der Inbetriebnahme des Produkts durchgelesen werden.
- Die Sicherheits- und Bedienungsanweisungen müssen zum Nachschlagen aufbewahrt werden.
- Alle Warnungen am Produkt oder in der Bedienungsanleitung müssen befolgt werden.
- Alle Bedienungsanweisungen müssen befolgt werden.

NETZANSCHLUSS

Die vorgeschriebene Betriebsspannung für dieses Produkt beträgt 120 V Wechselstrom (für USA und Kanada) und 220 – 240 V Wechselstrom (für europäische Länder oder Vereinigtes Königreich). Das angebrachte Netzkabel entspricht den folgenden Angaben für Netzspannung und Länder. Verwenden Sie nur das vorgeschriebene Netzkabel, um Sicherheitsregeln und EMV-Vorschriften des betreffenden Landes zu erfüllen.

- Nicht alle Typen von Netzkabeln sind mit diesem Produkt mitgeliefert.

Für USA und Kanada:
120 V Wechselstrom

Für europäische und
asiatische Länder:
220 – 240 V Wechselstrom

Für Vereinigtes
Königreich: 220 – 240 V
Wechselstrom



Dieser Stecker passt nur in eine geerdete Steckdose. Wenn Sie den Stecker nicht in die Steckdose stecken können, wenden Sie sich an Ihren Elektriker zum Einbau einer richtigen Steckdose. Umgehen Sie nicht die Sicherheitsfunktion des geerdeten Steckers.

- Dieses Produkt darf nur mit dem auf dem Typenschild angegebenen Netzstrom betrieben werden. Wenn Sie sich über die in Ihrem Haushalt vorhandene Netzspannung nicht sicher sind, lassen Sie sich von Ihrem Fachhändler oder beim Energieversorgungsunternehmen beraten.

Achtung:

- Verwenden Sie nicht das gleiche Netzkabel für 120 V Wechselstrom wie für 220 – 240 V Wechselstrom. Dabei besteht die Gefahr von Fehlfunktionen, elektrischen Schlägen oder Bränden.

Hinweise nur für Netzkabel im Vereinigten Königreich

Der im Netzkabel für das Vereinigte Königreich verwendete Stecker hat eine eingebaute Sicherung. Bei einem Sicherungswechsel ausschließlich eine geeignete Sicherung mit der erforderlichen Belastbarkeit einlegen und das Sicherungsfach schließen. (Lassen Sie sich von Ihrem Fachhändler oder einem qualifizierten Fachmann beraten.)

Sicherungswechsel

Öffnen Sie das Sicherungsfach mit dem Schlitzschraubenzieher und ersetzen Sie die Sicherung.

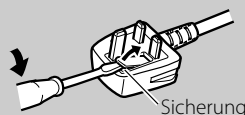

- Vor dem Anschluss anderer Produkte wie Videorecordern und Personalcomputern sollten Sie dieses Produkt zum Schutz gegen elektrische Schläge ausschalten.
- Verwenden Sie keine Verbindungsteile, die nicht vom Hersteller empfohlen sind, da dies gefährlich sein kann.
- **Wenn Teile ausgetauscht werden müssen**, stellen Sie sicher, dass der Servicetechniker Ersatzteile verwendet, die vom Hersteller vorgeschrieben sind oder zumindest gleichwertige Teile. Bei Verwendung unzulässiger Ersatzteile können Brände, elektrische Schläge und andere Gefahren verursacht werden.
- **Nach der Fertigstellung von Wartungsarbeiten oder Reparaturen an diesem Produkt bitten Sie den Wartungstechniker**, Sicherheitsprüfungen auszuführen, um sicherzustellen, dass das Produkt in gutem Betriebszustand ist.

- Stellen Sie dieses Produkt nicht an den folgenden Orten auf:
 - in einem feuchten oder staubigen Raum
 - an Orten, wo das Produkt Russ oder Dampf ausgesetzt ist, wie in der Nähe von Küchenherden oder Luftbefeuchtern
 - in der Nähe von Hitzequellen
 - an Orten, wo leicht Kondensation auftritt, wie nahe an Fenstern
 - an einem Ort, der direktem Sonnenlicht oder starkem Kunstlicht ausgesetzt ist
- Stellen Sie dieses Produkt nicht auf einem instabilen Wagen, Ständer oder Tisch auf. Das Produkt könnte herunterfallen und gefährliche Verletzungen, besonders bei Kindern, verursachen, ebenso wie Sachschäden.
- Das Produkt muss immer entsprechend den Herstellerangaben und unter Verwendung der vom Hersteller empfohlenen Halterungen aufgestellt werden.
- Dieses Produkt nicht in der Nähe von Wasser verwenden.
- Stellen Sie das Produkt immer nur an einem Ort auf, wo die richtige Temperatur und Luftfeuchtigkeit bewahrt werden (☞ „Betriebsbedingungen“ auf Seite 45).
- Dieses Produkt erhitzt sich beim Betrieb. Gehen Sie mit dem Produkt grundsätzlich vorsichtig um.

Unter den folgenden Bedingungen,

1. Ausschalten.
2. Trennen Sie das Produkt von der Netzsteckdose.
3. Wartungsarbeiten müssen qualifiziertem Fachpersonal überlassen werden.
 - a) Wenn das Produkt Rauch oder ungewöhnliche Gerüche abgibt.
 - b) Wenn das Produkt eine deutliche Leistungsabweichung aufweist — zum Beispiel kein Bild oder kein Ton.
 - c) Falls Flüssigkeit auf das Produkt geschüttet wurde oder Gegenstände eingedrungen sind.
 - d) Wenn das Produkt Regen oder Wasser ausgesetzt wurde.
 - e) Wenn das Produkt fallengelassen oder auf irgendeine Weise beschädigt wurde.
 - f) Wenn das Netzkabel oder der Stecker beschädigt ist.

Sicherheitsmaßregeln (Forts.)

Versuchen Sie nicht, das Produkt selber zu warten, wie etwa durch Öffnen von Abnehmen von Abdeckungen. Im Inneren befinden sich Teile mit gefährlicher Hochspannung und andere Gefahrenquellen. Überlassen Sie alle Wartungsarbeiten dem qualifizierten Kundendienst.

Verwenden Sie das Produkt nicht längere Zeit, wenn der Klang verzerrt ist.

Ausschließlich mit der zulässigen Netzspannung.

- Netzstrom: 120 V/220 - 240 V, 50 Hz/60 Hz

- Die Netzstromversorgung wird durch Ein-/Ausschalten des Netzschalters (POWER) an der Rückseite gesteuert. Wenn das Produkt an einem Ort aufgestellt ist, wo er sich nicht leicht mit dem Netzschalter ein-/ausschalten lässt, steuern Sie die Netzstromversorgung durch Einstecken/Abziehen des Netzkabels von der bzw. in die Netzsteckdose. In diesem Fall stellen Sie das Produkt so nahe an einer Netzsteckdose wie möglich auf, und lassen Sie ausreichend Platz zum Einstecken/Abziehen des Netzkabels. Wenn das Produkt an einem Ort aufgestellt ist, wo das Netzkabel nicht leicht zum Einstecken/Abziehen erreichbar ist, richten Sie einen Ein-/Aus-Schalter für die betreffende Steckdose ein.
- Wenn das Produkt längere Zeit unbeaufsichtigt stehengelassen wird, ziehen Sie den Netzstecker ab und trennen die Kabelverbindungen der Anlage.
- Überlasten Sie nicht Wandsteckdosen, Verlängerungskabel, Verteilerstecker oder andere elektrische Teile, da dadurch die Gefahr von Bränden oder elektrischen Schlägen entstehen kann.
- Verwenden Sie nur das für dieses Produkt gedachte Netzkabel, um die Gefahr elektrischer Schläge zu vermeiden.

- Schlitze und Öffnungen im Gehäuse sind zur Lüftung vorhanden. Die stellen zuverlässigen Betrieb des Produkt sicher und schützen es vor Überhitzung. Diese Öffnungen dürfen nicht verstopft oder verdeckt werden.
- Niemals Gegenstände jeglicher Art durch die Öffnungen in das Produkt drücken, da sie unter Spannung stehende Teile berühren oder Kurzschlüsse verursachen können, was zu Bränden oder elektrischen Schlägen führen kann.
- Niemals Flüssigkeiten jeglicher Art auf das Produkt schütten.
- Legen Sie keine Gegenstände auf dem Produkt ab. (Wenn Flüssigkeiten, nackte Flammen, Kleidungsstücke, Papier usw. auf dem Produkt abgelegt werden, besteht die Gefahr von Bränden.)
- Das LCD-Panel niemals starken Stößen aussetzen. (Nicht an Gegenstände anstoßen lassen oder mit einem scharfen Werkzeug drücken.)
- Stellen Sie keine schweren Gegenstände auf das Produkt.
- Treten Sie nicht auf das Produkt oder ziehen sich daran hoch.

WARNUNG

Zum Verhindern von Verletzungen durch versehentliches Herunterfallen

Bringen Sie den Monitor mit Drähten an einer Wand an.

Anbringen des Monitors

Bringen Sie den Haken (nicht mitgeliefert) an die VESA-Montagelöcher an der Rückseite (verwenden Sie die beiden Löcher an der Oberseite) mit den Schrauben M4 x 10 mm (nicht mitgeliefert) an. Binden Sie die Haken an der Rückseite des Monitors an einer Wand oder einer Säule mit haltbarem Faden fest.

VESA-Montagelöcher

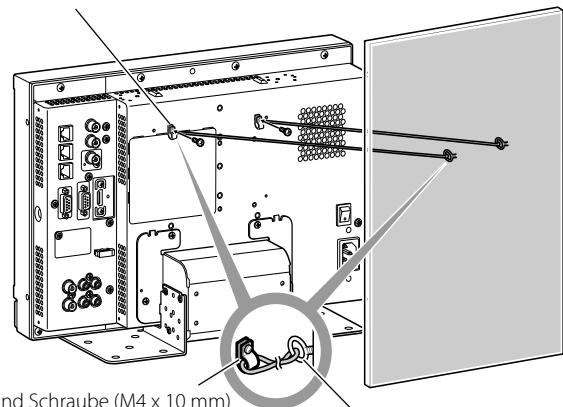

Haken und Schraube (M4 x 10 mm)
(nicht mitgeliefert)

Haken (nicht mitgeliefert)

Nur Europäische Union

Sehr geehrter Kunde,

Dieses Gerät entspricht den gültigen europäischen Richtlinien und Normen bezüglich elektromagnetischer Verträglichkeit und elektrischer Sicherheit.

Die europäische Vertretung von JVC KENWOOD Corporation ist: JVC Technical Services Europe GmbH
Postfach 10 05 04
61145 Friedberg
Deutschland

Benutzerinformationen zur Entsorgung alter Geräte

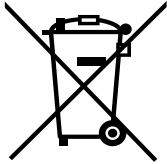

[Europäische Union]

Dieses Symbol zeigt an, dass das elektrische bzw. elektronische Gerät nicht als normaler Haushaltsabfall entsorgt werden soll. Stattdessen sollte das Produkt zur fachgerechten Entsorgung, Weiterverwendung und Wiederverwertung in Übereinstimmung mit der Landesgesetzgebung einer entsprechenden Sammelstelle für das Recycling elektrischer und elektronischer Geräte zugeführt werden.

Hinweis:

Dieses Symbol ist nur in der Europäischen Union gültig.

Die korrekte Entsorgung dieses Produkts dient dem Umweltschutz und verhindert mögliche Schäden für die Umwelt und die menschliche Gesundheit, welche durch unsachgemäße Behandlung des Produkts auftreten können.

Weitere Informationen zu Sammelstellen und dem Recycling dieses Produkts erhalten Sie bei Ihrer Gemeindeverwaltung, Ihrem örtlichen Entsorgungsunternehmen oder in dem Geschäft, in dem Sie das Produkt gekauft haben.

Für die nicht fachgerechte Entsorgung dieses Abfalls können gemäß der Landesgesetzgebung Strafen ausgesprochen werden.

(Geschäftskunden)

Wenn Sie dieses Produkt entsorgen möchten, besuchen Sie bitte unsere Webseite <http://www.jvc.eu/> um Informationen zur Rücknahme des Produkts zu erhalten.

[Andere Länder außerhalb der Europäischen Union]

Wenn Sie dieses Produkt entsorgen möchten, halten Sie sich dabei bitte an die entsprechenden Landesgesetze und andere Regelungen in Ihrem Land zur Behandlung elektrischer und elektronischer Geräte.

EMV-Ergänzung

Dieses Gerät entspricht den Vorschriften und Schutzanforderungen der entsprechenden europäischen Richtlinien. Dieses Gerät ist für professionelle Videoausrüstungen ausgelegt und kann in den folgenden Umgebungen verwendet werden:

- Umgebung mit kontrollierter EMV (zum Beispiel speziell gebaute Sende- oder Aufnahmestudios) und ländliche Umgebungen im Freien (weit von Eisenbahnen, Sendern, Starkstromleitungen usw. entfernt).

Um die beste Leistung zu bewahren und elektromagnetische Verträglichkeit sicherzustellen, empfehlen wir, Kabel zu verwenden, die die folgende Länge nicht überschreiten:



Kabel	Länge
Netzkabel	2,0 m
(befestigtes Kabel (H05VV-F 3 x 0,75 mm ²))	
Videosignalkabel (Koaxialkabel)	2,0 m
Audiosignalkabel (abgeschirmtes Kabel)	1,5 m
HDMI-Kabel (abgeschirmtes Kabel)	2,0 m
DVI-Kabel (abgeschirmtes Kabel) mit Kernfilter	2,0 m
RS-232C-Kabel (abgeschirmtes Kabel)	2,0 m
(Ein Direktverbindungskabel mit einem D-sub 9-Pin-Anschluss)	
RS-485-Kabel (verdrilltes Leiterpaarkabel)	2,0 m
(Ein direktverbindendes LAN-Kabel)	
REMOTE-Kabel (verdrilltes Leiterpaarkabel)	2,0 m
(Ein direktverbindendes LAN-Kabel)	
RGB VGA-Kabel (abgeschirmtes Kabel)	2,0 m

Der Einschaltstrom dieses Geräts beträgt 4,24 Ampere.

ACHTUNG

Wenn starke elektromagnetische Wellen oder Magnetismus in der Nähe des Audiokabels oder Signalkabels sind, können Ton oder Bild durch Rauschen gestört werden. In solchen Fällen verlegen Sie das Kabel bitte weiter von den Störquellen entfernt.

Précautions de sécurité

 CAUTION RISK OF ELECTRICAL SHOCK DO NOT OPEN 	<p>The lightning flash with arrowhead symbol, within an equilateral triangle is intended to alert the user to the presence of uninsulated "dangerous voltage" within the product's enclosure that may be of sufficient magnitude to constitute a risk of electric shock to persons.</p> <p>The exclamation point within an equilateral triangle is intended to alert the user to the presence of important operating and maintenance (servicing) instructions in the literature accompanying the appliance.</p>
<p>CAUTION: To reduce the risk of electric shock. Do not remove cover (or back). No user serviceable parts inside. Refer servicing to qualified service personnel.</p>	

AVERTISSEMENT: POUR RÉDURE LES RISQUES D'INCENDIE ET D'ÉLECTROCUTION, N'EXPOSEZ PAS CET APPAREIL À LA PLUIE NI À L'HUMIDITÉ. AUCUN OBJET REMPLI DE LIQUIDE, TEL QU'UN VASE, NE DOIT ÊTRE PLACÉ SUR L'APPAREIL.

Avertissement: C'est un produit de classe A. Dans un environnement domestique, cet appareil peut causer des interférences radio et dans ce cas l'utilisateur peut être requis de prendre les mesures correctives nécessaires.

INSTRUCTIONS DE SÉCURITÉ IMPORTANTES

L'énergie électrique peut effectuer de nombreuses fonctions utiles. Cet appareil a été conçu et fabriqué pour garantir votre propre sécurité. Mais **UN USAGE INCORRECT PEUT CAUSER UNE ÉVENTUELLE ÉLECTROCUTION OU DES RISQUES D'INCENDIE**. Pour ne pas anéantir les dispositifs de sécurité intégrés à cet appareil, observez les règles de base suivantes pour son installation, utilisation et entretien. Veuillez lire attentivement ces "INSTRUCTIONS DE SÉCURITÉ IMPORTANTES" avant d'utiliser l'appareil.

- Lisez toutes les instructions de sécurité et de fonctionnement avant d'utiliser cet appareil.
- Conservez les instructions de sécurité de fonctionnement à titre de référence.
- Conformez-vous à tous les avertissements sur l'appareil ou dans les instructions de fonctionnement.
- Suivez toutes les instructions de fonctionnement.

RACCORDEMENT DE L'ALIMENTATION

La tension d'alimentation de cet appareil est de CA 120 V (pour les États-Unis et le Canada) et de CA 220 – 240 V (pour les pays européens et asiatique et le Royaume-Uni).

Le cordon d'alimentation fourni est conforme aux tensions d'alimentation et aux pays suivants. Utilisez uniquement le cordon d'alimentation conçu pour garantir la sécurité et les règlements EMC de chaque pays.

- Tous les types de cordon d'alimentation ne sont pas fournis avec cet appareil.

Pour les États-Unis et le Canada: CA 120 V

Pour les pays d'Europe et d'Asie: CA 220 – 240 V

Pour le Royaume-Uni: CA 220 – 240 V



Cette fiche rentre seulement dans une prise secteur avec terre. Si vous ne pouvez pas introduire la fiche dans la prise, contacter votre électricien pour installer une prise correcte. N'outrepassez pas les mesures de sécurité de la fiche avec mise à la terre.

- Cet appareil doit être utilisé uniquement avec le type de source d'alimentation indiqué sur l'étiquette. Si vous n'êtes pas sûr du type d'alimentation de votre maison, consulter votre revendeur d'appareils ou la compagnie locale d'électricité.

Avertissement:

- N'utilisez pas le même cordon d'alimentation pour CA 120 V et CA 220 – 240 V. Cela pourrait causer un mauvais fonctionnement, des chocs électriques ou un incendie.

Remarque pour le cordon d'alimentation du Royaume-Uni uniquement

La fiche du cordon d'alimentation de type Royaume-Uni a un fusible intégré. Lors du remplacement du fusible, assurez-vous d'utiliser uniquement un type approuvé correctement calibré, et de remettre le capot de fusible. (Consulter votre revendeur ou un personnel qualifié.)

Comment remplacer le fusible

Ouvrez le compartiment à fusible avec un tournevis plat, et remplacez le fusible.

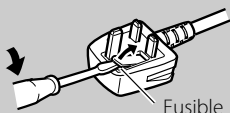

- Avant la connexion d'autres appareils tels qu'un magnétoscope et un ordinateur personnel, vous devez mettre cet appareil hors tension pour vous protéger contre les chocs électriques.
- N'utilisez pas de fixations non recommandées par le fabricant, elles pourraient présenter des dangers.
- **Si des pièces de remplacement sont nécessaires**, assurez-vous que le technicien de service a utilisé des pièces de remplacement spécifiées par le fabricant ou des pièces équivalentes. Des remplacements non autorisés peuvent entraîner un incendie, une électrocution ou d'autres dangers.
- **Après tout dépannage ou réparation de cet appareil**, demander au technicien de service d'effectuer les tests de sécurité pour s'assurer que le produit est dans un état de fonctionnement correct.

- N'installez pas cet appareil dans les endroits suivants:
 - dans une pièce humide ou poussiéreuse
 - où l'appareil est exposé à la suie ou à la vapeur, comme près d'une cuisinière ou d'un humidificateur
 - près d'une source de chaleur
 - dans un endroit où la condensation se produit facilement, comme près d'une fenêtre
 - dans un endroit exposé à la lumière directe du soleil ou un fort éclairage
- Ne placez pas ce produit sur un chariot, un socle ou une table instables. L'appareil pourrait tomber, causant des blessures sérieuses à un enfant ou à un adulte, et être sérieusement endommager. Cet appareil doit être monté conformément aux instructions du fabricant et doit utiliser un support de montage recommandé par le fabricant.
- N'utilisez pas cet appareil près de l'eau.
- Assurez-vous d'installer le produit dans un endroit où une température et une humidité correcte est maintenue (☞ "Conditions de fonctionnement" à la page 45). Cet appareil devient chaud pendant son utilisation. Faites attention lors de la manipulation du produit.

Sous les conditions suivantes,

1. Mettez l'appareil hors tension.
2. Débranchez cet appareil de la prise secteur.
3. Confiez les réparations à un personnel de service qualifié.
 - a) Si l'appareil émet de la fumée ou une odeur inhabituelle.
 - b) Si l'appareil affiche un brusque changement dans ses performances—par exemple, s'il n'y a pas d'image ou de son.
 - c) Si un liquide a coulé, ou si des objets sont tombés sur l'appareil.
 - d) Si l'appareil a été exposé à la pluie ou l'eau.
 - e) Si l'appareil est tombé ou a été endommagé de quelque façon.
 - f) Quand le cordon ou la fiche secteur est endommagé.

N'essayez pas de réparer vous même cet appareil, car ouvrir ou retirer des couvercles vous exposerait à des tensions dangereuses ou d'autres dangers. Confier toutes les réparations à un personnel de service qualifié.

N'utilisez pas l'appareil pendant une longue période temps si le son est déformé.

N'utiliser que la source d'alimentation spécifiée sur l'appareil.

- Alimentation secteur: 120 V/220 - 240 V, 50 Hz/60 Hz

- L'alimentation secteur est commandée par la mise sous/hors tension au niveau de l'interrupteur POWER sur le panneau arrière. Si l'appareil est installé dans un endroit où il ne peut pas être mis facilement sous/hors tension au niveau de l'interrupteur POWER, commandez l'alimentation en branchant/débranchant le cordon d'alimentation sur/de la prise secteur murale. Dans ce cas, installez l'appareil aussi près que possible de la prise secteur, et laissez suffisamment d'espace pour pouvoir brancher/débrancher le cordon d'alimentation. Si l'appareil est installé dans un endroit où vous ne pouvez pas brancher/débrancher facilement le cordon d'alimentation, installez un dispositif de mise en/hors tension facilement accessible.
- Si l'appareil doit être laissé sans surveillance et inutilisé pendant une période prolongée, débranchez-le de la prise murale et débranchez le système câblé.
- Ne surchargez pas les prises de courant murales, des cordons prolongateurs ni des prises de courant d'autre type sur d'autres appareils, car cela pourrait entraîner une électrocution ou un d'incendie.
- Utilisez uniquement le cordon fourni conçu pour cet appareil pour éviter tout choc électrique.

- Des fentes et des ouvertures dans le coffret sont prévues pour la ventilation. Elles assure une fonctionnement fiable de l'appareil et le protègent d'une surchauffe. Ces ouvertures ne doivent pas être bloquées ni recouvertes.
- Ne jamais pousser des objets de toute sorte dans ce produit par les ouvertures, ils pourraient toucher des points sous tension dangereux ou court-circuiter des pièces, ce qui pourrait causer une électrocution ou un incendie.
- Ne versez jamais de liquide sur l'appareil.
- Ne placez jamais rien sur l'appareil. (Ne posez jamais de liquides, flammes nues, vêtements, papiers, etc. sur l'appareil. Ce pourrait être cause d'incendie.)
- Ne soumettez pas le panneau à cristaux liquides à des chocs importants. (Ne frappez pas ni ne touchez le moniteur avec un objet pointu.)
- Ne placez pas d'objet lourd sur l'appareil.
- Ne marchez pas sur l'appareil ni ne vous y penchez.

AVERTISSEMENT

Pour éviter les blessures causées par une chute accidentelle

Fixez le moniteur sur un mur en utilisant des cordes.

Fixation du moniteur

Attachez le crochet (non fourni) autres trous de montage VESA sur le panneau arrière (utilisez les deux trous de la partie supérieure) en utilisant des vis M4 x 10 mm (non fournies). Attachez les crochets du panneau arrière du moniteur sur un mur ou un pilier en utilisant une corde durable.

Trous de montage VESA

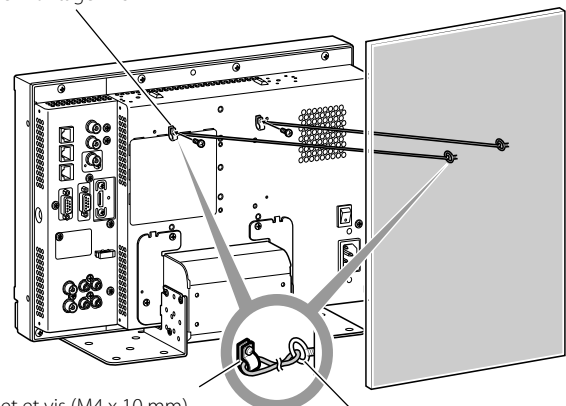

Crochet et vis (M4 x 10 mm)
(non fournis)

Crochet (non fourni)

Précautions de sécurité (suite)

Union européenne uniquement

Cher(e) client(e),

Cet appareil est conforme aux directives et normes européennes en vigueur concernant la compatibilité électromagnétique et à la sécurité électrique.

Le représentant européen de JVC KENWOOD Corporation est:
JVC Technical Services Europe GmbH
Postfach 10 05 04
61145 Friedberg
Allemagne

Informations relatives à l'élimination des appareils usagés, à l'intention des utilisateurs



[Union européenne]

Lorsque ce symbole figure sur un appareil électrique et électronique, cela signifie qu'il ne doit pas être éliminé en tant que déchet ménager à la fin de son cycle de vie. Le produit doit être porté au point de pré-collecte approprié au recyclage des appareils électriques et électroniques pour y subir un traitement, une récupération et un recyclage, conformément à la législation nationale.

Attention:

Ce symbole n'est reconnu que dans l'Union européenne.

En éliminant correctement ce produit, vous contribuez à la conservation des ressources naturelles et à la prévention des éventuels effets négatifs sur l'environnement et la santé humaine, pouvant être dus à la manipulation inappropriée

des déchets de ce produit. Pour plus d'informations sur le point de pré-collecte et le recyclage de ce produit, contactez votre mairie, le service d'évacuation des ordures ménagères ou le magasin dans lequel vous avez acheté le produit.

Des amendes peuvent être infligées en cas d'élimination incorrecte de ce produit, conformément à la législation nationale.

(Utilisateurs professionnels)

Si vous souhaitez éliminer ce produit, visitez notre page Web <http://www.jvc.eu/> afin d'obtenir des informations sur sa récupération.

[Pays ne faisant pas partie de l'Union européenne]

Si vous souhaitez éliminer ce produit, faites-le conformément à la législation nationale ou autres règles en vigueur dans votre pays pour le traitement des appareils électriques et électroniques usagés.

Supplément EMC

Ce matériel est en conformité avec les provisions et exigences de protection des directives européennes correspondantes. Ce matériel est conçu pour des applications vidéo professionnelles et peut être utilisé dans les milieux suivants:

- Milieux contrôlés EMC (par exemple studio d'enregistrement ou conçu pour la diffusion), et en extérieur (loin des lignes de chemins de fer, des émetteurs, des lignes aériennes haute tension, etc.)
- Pour maintenir la meilleure performance et pour assurer la compatibilité électromagnétique, nous recommandons l'utilisation de câbles n'excédant pas les longueurs suivantes:



Câble	Longueur
Cordon d'alimentation (câble fourni (H05VV-F 3 x 0.75 mm ²))	2,0 m
Câble de signal vidéo (câble coaxial)	2,0 m
Câble de signal audio (câble blindé)	1,5 m
Câble HDMI (câble blindé)	2,0 m
Câble DVI (câble blindé) avec un filtre à noyau de ferrite	2,0 m
Câble RS-232C (câble blindé) (Un câble rectiligne avec un connecteur D-Sub 9 broches)	2,0 m
Câble RS-485 (câble à paire torsadée) (Un câble réseau rectiligne)	2,0 m
Câble REMOTE (câble à paire torsadée) (Un câble réseau rectiligne)	2,0 m
Câble RGB VGA (câble blindé)	2,0 m

L'appel de courant de cet appareil est de 4,24 ampères.

PRÉCAUTION

Dans le cas où il y a des ondes électromagnétiques puissantes ou du magnétisme près du câble audio ou du câble de signal, le son ou l'image contiendra du bruit. Dans ce cas, veuillez éloigner le câble des sources de la perturbation.

Precauzioni di sicurezza

 CAUTION RISK OF ELECTRICAL SHOCK DO NOT OPEN 	<p>The lightning flash with arrowhead symbol, within an equilateral triangle is intended to alert the user to the presence of uninsulated "dangerous voltage" within the product's enclosure that may be of sufficient magnitude to constitute a risk of electric shock to persons.</p> <p>The exclamation point within an equilateral triangle is intended to alert the user to the presence of important operating and maintenance (servicing) instructions in the literature accompanying the appliance.</p>
<p>CAUTION: To reduce the risk of electric shock. Do not remove cover (or back). No user serviceable parts inside. Refer servicing to qualified service personnel.</p>	

AVVERTENZA: AL FINE DI RIDURRE IL RISCHIO DI INCENDIO O DI SCOSSE ELETTRICHE NON SI DEVE ESPORRE L'APPARECCHIO ALLA PIOGGIA O ALL'UMIDITÀ. L'APPARECCHIO NON DEVE ESSERE USATO COME PIANO DI APPOGGIO PER CONTENITORI DI LIQUIDI.

Avvertenza: Prodotto di classe A. In ambiente domestico il prodotto può provocare radiodisturbi che l'utente è tenuto ad eliminare adottando idonee misure.

NOTE IMPORTANTI SULLA SICUREZZA

L'energia elettrica può rendere grossi servizi. Questo apparecchio è stato concepito e costruito per garantire la sicurezza di chi lo usa. **L'USO NON APPROPRIATO DELL'APPARECCHIO PUÒ TUTTAVIA DIVENIRE CAUSA DI SCOSSA ELETTRICA O D'INCENDIO.** Per non vanificare i dispositivi di sicurezza in esso incorporati si raccomanda di seguire le istruzioni fondamentali per l'installazione, l'uso e la manutenzione qui oltre riportate. Prima dell'uso leggere attentamente le presenti "NOTE IMPORTANTI SULLA SICUREZZA".

- Prima di mettere in funzione l'apparecchio se ne devono leggere le istruzioni di sicurezza e di funzionamento.
- Conservare le istruzioni relative al funzionamento e alla sicurezza per consultazioni future.
- Rispettare tutte le avvertenze riportate sull'apparecchio e nelle istruzioni per l'uso.
- Seguire tutte le istruzioni per l'uso.

- Per evitare qualsiasi scossa elettrica si raccomanda di spegnere il monitor prima di collegarvi altri apparecchi quali, ad esempio, un videoregistratore o un personal computer.
- Non si devono fissare all'apparecchio parti che non siano state raccomandate dal produttore, poiché ciò potrebbe comportare pericoli.
- **Qualora si renda necessaria la sostituzione di alcune parti,** si raccomanda di verificare che il tecnico di riparazione usi esclusivamente quelle specificate dal costruttore oppure di caratteristiche analoghe. L'uso di ricambi non originali può provocare incendi, scosse elettriche ed altri rischi.
- **Al termine degli interventi di manutenzione e di riparazione dell'apparecchio,** chiedere ai tecnici di manutenzione di eseguire i controlli di sicurezza per accertarsi che l'apparecchio funzioni regolarmente.

COLLEGAMENTO DELL'ALIMENTAZIONE

La tensione di alimentazione nominale di questo apparecchio è 120 V CA (per gli Stati Uniti d'America e il Canada) e 220 - 240 V CA (per i Paesi Europei, compreso il Regno Unito, e i Paesi dell'Asia). Il cavo di alimentazione fornito in dotazione è conforme alle tensioni di alimentazione qui di seguito indicate per i rispettivi Paesi. Utilizzare esclusivamente cavi di alimentazione che garantiscono la sicurezza e la conformità alle norme di compatibilità elettromagnetica di ciascun Paese.

- Nella fornitura di questo apparecchio non sono inclusi tutti i tipi di cavo.

Per gli U.S.A. e il Canada: 120 V CA	Per i Paesi Europei e Asiatici: 220 - 240 V CA	Per il Regno Unito: 220 - 240 V CA
--------------------------------------	--	------------------------------------



Questa spina può essere inserita solo in una presa dotata di messa a terra. Se non è possibile inserire la spina nella presa si raccomanda di rivolgersi a un elettricista di fiducia affinché ne installi una di caratteristiche adeguate. Non si devono vanificare gli scopi di sicurezza delle prese dotate del contatto di messa a terra.

- L'apparecchio deve essere usato esclusivamente con il tipo di alimentazione elettrica indicato sull'etichetta. In caso di dubbi sul tipo di sorgente di alimentazione da utilizzare, consultare il rivenditore o la compagnia di fornitura di alimentazione locale.

Avvertenza:

- Si raccomanda di non usare per la tensione di 120 V CA lo stesso cavo di alimentazione destinato alla tensione di 220 - 240 V CA. In caso contrario si potrebbero generare malfunzionamenti, un

Nota esclusiva per il cavo di alimentazione destinato al Regno Unito

La spina del cavo di alimentazione per il Regno Unito presenta un fusibile integrato. Qualora si renda necessario sostituirlo si raccomanda di usarne esclusivamente uno di caratteristiche nominali corrette e, quindi, di riapplicare il coperchio del portafusibile (rivolgendosi al proprio rivenditore o a un tecnico qualificato).

Come sostituire il fusibile

Aprire il vano portafusibile con la punta di un cacciavite piatto e sostituire il fusibile.

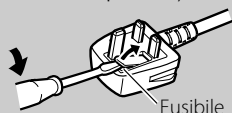

- L'apparecchio non deve essere installato:
 - in ambienti umidi o polverosi
 - in ambienti fuliginosi o saturi di vapore, ad esempio in cucina o nelle vicinanze di un umidificatore
 - nelle vicinanze di un radiatore di calore
 - in punti in cui si formi condensa con una certa facilità, ad esempio vicino a una finestra
 - in un luogo che lo esponga alla luce solare diretta o a forte luce artificiale
- L'apparecchio non deve essere collocato su carrelli, supporti o tavoli instabili. Potrebbe infatti cadere con conseguente rischio di gravi infortuni sia agli adulti sia ai bambini nonché gravi danni all'apparecchio stesso. L'apparecchio dev'essere installato secondo le istruzioni della casa produttrice, utilizzando un supporto omologato dalla stessa.
- Non usare l'apparecchio in prossimità dell'acqua.
- L'apparecchio deve essere usato in luoghi mantenuti a un livello corretto di temperatura e di umidità (☞ "Condizioni d'uso" a pagina 45). Durante l'uso il monitor si scalda. È quindi necessario maneggiarlo con molta attenzione.

Nelle situazioni qui oltre elencate si deve:

1. **Spegnere l'apparecchio.**
2. **Scollegare il cavo di alimentazione dalla presa di rete.**
3. **Rivolgersi a personale di assistenza qualificato.**
 - a) Quando l'apparecchio inizia a produrre fumo o odori anomali.
 - b) Quando le prestazioni dell'apparecchio appaiono visibilmente deteriorate, ad esempio qualora non produca più immagini o suono.
 - c) Quando vi è stato versato del liquido o vi sono caduti oggetti.
 - d) Quando l'apparecchio è rimasto esposto alla pioggia o all'acqua.
 - e) Quando l'apparecchio è caduto o ha comunque subito danni.
 - f) Quando il cavo di alimentazione o la spina si è danneggiata.

Precauzioni di sicurezza (cont.)

Non tentare di riparare l'apparecchio da sé, poiché l'apertura o la rimozione dei coperchi può esporre a tensioni pericolose o ad altri pericoli. Si raccomanda piuttosto di rivolgersi a personale tecnico qualificato.

Non usare l'apparecchio a lungo qualora il suono sia distorto.

Usare solamente le sorgenti di alimentazione specificate sull'apparecchio.

- Alimentazione CA: 120 V/220 - 240 V, 50 Hz/60 Hz

- L'alimentazione CA dell'apparecchio è controllabile agendo sull'interruttore POWER del pannello posteriore. Se l'apparecchio è installato in un punto in cui non sia facile accenderlo o spegnerlo con l'interruttore POWER, lo si può accendere o spegnere scollegando direttamente il cavo di alimentazione CA dalla presa di rete. In tal caso si deve installare l'apparecchio quanto più possibile vicino alla presa di rete e lasciare spazio sufficiente per l'inserimento e l'estrazione della spina. Qualora lo si debba installare in un punto in cui l'inserimento e l'estrazione della spina risultino difficoltosi, per accendere e spegnere l'apparecchio si suggerisce di fare installare un apposito sezionatore sulla linea elettrica.
- Quando s'intende lasciare l'apparecchio incustodito oppure inutilizzato per lungo tempo è raccomandabile scollegare il cavo di alimentazione dalla presa di rete CA oltre che i cavi di sistema.
- Non sovraccaricare le prese di rete, le prolunghe o le prese di servizio di altri apparecchi, poiché ciò potrebbe comportare pericolo d'incendio e di scossa elettrica.
- Per evitare le scosse elettriche si devono usare esclusivamente i cavi per accessori specificati per questo apparecchio.

- Le feritoie e le aperture dell'involucro dell'apparecchio servono per la ventilazione. La ventilazione è necessaria per garantire il funzionamento affidabile dell'apparecchio e impedirne inoltre il surriscaldamento. Tali aperture non devono essere pertanto bloccate né ostruite.
- Non introdurre alcun tipo di oggetto nell'apparecchio attraverso le proprie aperture, in quanto potrebbe raggiungere punti a tensioni pericolose o provocare cortocircuiti con conseguente pericolo d'incendio o di scossa elettrica.
- Non versare sull'apparecchio liquidi di alcun tipo.
- Sul monitor non si deve collocare alcun oggetto o corpo estraneo. (Liquidi, fiamme libere, tessuti, carta e così via potrebbero infatti divenire causa d'incendio.)
- Non si deve sottoporre il pannello LCD a forti urti. (Né lo si deve colpire con altri corpi o premerlo con oggetti appuntiti).
- Non appoggiare oggetti pesanti sull'apparecchio.
- Non si deve salire sul monitor né ci si deve aggrappare.

AVVERTENZA

Per impedire la caduta accidentale del monitor e conseguenti lesioni alle persone

Fissare il monitor a una parete usando cavi robusti.

Fissaggio del monitor

Con le viti M4 x 10 mm (non fornite in dotazione all'apparecchio) fissare i ganci (anch'essi non forniti) ai due fori di montaggio VESA ubicati sul pannello posteriore in posizione superiore. Fissare quindi ai ganci due cavetti robusti la cui estremità opposta dovrà a sua volta essere fissata a una parete o a una colonna.

Fori per montaggio VESA

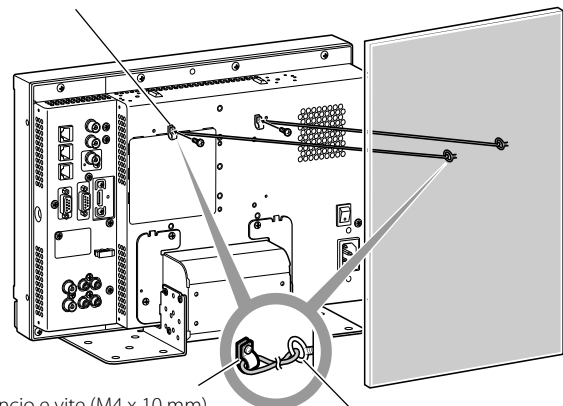

Gancio e vite (M4 x 10 mm)
(non fornito in dotazione)

Gancio (non fornito in dotazione)

Esclusivamente per i Paesi dell'Unione Europea

Gentile Cliente,

questo apparecchio è conforme alle direttive e alle norme europee vigenti relative alla compatibilità elettromagnetica e alla sicurezza dei dispositivi elettrici.

Il rappresentante JVC KENWOOD per l'Europa è:

JVC Technical Services Europe GmbH

Postfach 10 05 04

61145 Friedberg

Germania

Informazioni per gli utenti sullo smaltimento delle apparecchiature obsolete



[Unione Europea]

Questo simbolo indica che l'apparecchio elettrico ed elettronico a cui è relativo non deve essere smaltito tra i rifiuti domestici generici alla fine della sua vita utile. Il prodotto, invece, va consegnato a un punto di raccolta appropriato per il riciclaggio di apparecchiature elettriche ed elettroniche, per il trattamento, il recupero e il riciclaggio corretti, in conformità alle proprie normative nazionali.

Attenzione:

Questo simbolo è valido solo nell'Unione Europea.

Mediante lo smaltimento corretto di questo prodotto, si contribuirà a preservare le risorse naturali e a prevenire potenziali effetti negativi sull'ambiente e sulla salute umana che potrebbero essere provocati, altrimenti, da uno

smaltimento inappropriato del prodotto. Per ulteriori informazioni sul punto di raccolta e il riciclaggio di questo prodotto, contattare la sede comunale locale, il servizio di smaltimento rifiuti domestici o il negozio in cui si è acquistato il prodotto.

L'utente è responsabile della corretta eliminazione di tali prodotti al termine della propria vita operativa in ottemperanza alla legislazione del proprio Paese.

(Per gli utenti aziendali)

Qualora si desideri smaltire questo prodotto, visitare la nostra pagina web <http://www.jvc.eu/> per ottenere informazioni sul ritiro del prodotto.

[Per altri Paesi al di fuori dell'Unione Europea]

Qualora si desideri smaltire questo prodotto, effettuare lo smaltimento in conformità alla normativa nazionale applicabile o alle altre leggi della propria nazione relative al trattamento delle apparecchiature

elettriche ed elettroniche obsolete.

Supplemento EMC (compatibilità elettromagnetica)

Questo apparecchio è conforme alle disposizioni e ai requisiti di protezione delle corrispondenti direttive Europee. Questo apparecchio è rivolto all'uso video professionale ed è impiegabile nei seguenti ambienti:

- Ambienti a controllo EMC, o compatibilità elettromagnetica (ad esempio negli studi di diffusione dedicati a scopi specifici) e in aree esterne isolate (lontane dalle stazioni ferroviarie, dai trasmettitori, dalle linee elettriche sospese, ecc.)

Per garantire il mantenimento delle prestazioni ottimali e la necessaria compatibilità elettromagnetica raccomandiamo di usare cavi che non eccedano la seguente lunghezza:

Cavo	Lunghezza
Cavo di alimentazione (cavo applicato (H05VV-F 3 x 0,75 mm ²))	2,0 m
Cavo dei segnali video (cavo coassiale)	2,0 m
Cavo dei segnali audio (schermato)	1,5 m
Cavo HDMI (schermato)	2,0 m
Cavo DVI (schermato) con filtro a nucleo di ferrite	2,0 m
Cavo RS-232C (schermato) (Un cavo dritto provvisto di connettore D-sub a 9 contatti)	2,0 m
Cavo RS-485 (cavo elettrico bipolare) (Un cavo LAN dritto)	2,0 m
Cavo REMOTE (cavo elettrico bipolare) (Un cavo LAN dritto)	2,0 m
Cavo RGB VGA (schermato)	2,0 m

La corrente di picco di questo apparecchio è di 4,24 ampere.

ATTENZIONE

Qualora nelle vicinanze del cavo audio o di quello dei segnali vi siano forti onde elettromagnetiche o comunque forti campi magnetici, il suono o le immagini potrebbero essere disturbate da rumore. In tal caso si raccomanda di mantenere questi cavi lontani da qualsiasi possibile fonte di disturbo.

Precauciones de seguridad



CAUTION
RISK OF ELECTRICAL SHOCK
DO NOT OPEN





El símbolo de relámpago con la punta en forma de flecha dentro de un triángulo equilátero tiene el propósito de alertar al usuario la presencia de "voltaje peligroso" no aislado dentro de la caja del producto, que puede tener la intensidad suficiente para constituir un riesgo de descarga eléctrica a las personas.



El signo de exclamación dentro de un triángulo equilátero tiene el propósito de alertar al usuario la presencia de instrucciones importantes de operación y mantenimiento (servicio) en la literatura que acompaña el aparato.

PRECAUCIÓN: Para reducir el riesgo de descargas eléctricas. No extraiga la cubierta (o pieza posterior). No hay partes internas que puedan ser reparadas por el usuario. Deje el servicio a personal de servicio cualificado.

ADVERTENCIA: PARA REDUCIR EL RIESGO DE INCENDIOS O DE DESCARGAS ELÉCTRICAS, NO EXPONGA ESTE APARATO A LA LLUVIA, O HUMEDAD. NO PONGA RECIPIENTES CONTENIENDO LÍQUIDOS, COMO FLOREROS, ENCIMA DEL APARATO.

Advertencia: Este es un producto de Clase A. En un entorno residencial, este producto puede causar interferencias, en cuyo caso el usuario debe tomar las medidas adecuadas.

SALVAGUARDAS IMPORTANTES

La energía eléctrica puede realizar numerosas funciones útiles. Esta unidad ha sido diseñada y fabricada para brindarle una operación de máxima seguridad. No obstante **EL USO INCORRECTO PUEDE PRODUCIR UN RIESGO DE CHOQUE ELÉCTRICO O INCENDIO.** Para no anular todas las salvaguardas incorporadas a este producto, asegúrese de respetar las reglas básicas siguientes para su instalación, uso y servicio. Por favor lea atentamente estas "SALVAGUARDAS IMPORTANTES" antes del uso.

- Todas las instrucciones de seguridad y de funcionamiento deben leerse antes de usar el producto.
- Las instrucciones de seguridad y de uso deben guardarse para futuras consultas.
- Deben respetarse todas las advertencias inscritas en el producto y descritas en las instrucciones de uso.
- Siga al pie de la letra todas las instrucciones de uso.

CONEXIÓN DE ALIMENTACIÓN

La tensión especificada para la fuente de alimentación de ese producto es 120 V CA (Para Estados Unidos y Canadá) y 220 – 240 V (Para los países europeos o asiáticos o el Reino Unido). El cable de alimentación adjunto cumple con la tensión de alimentación especificada para los siguientes países. Utilice únicamente el cable de alimentación designado por las normas de seguridad de EMC y seguridad eléctrica de cada país.

- No todos los tipos de cables de alimentación se suministran con este producto.

Para EE.UU. y Canadá: 120 V CA Para los países europeos y asiáticos: 220 – 240 V CA Para el Reino Unido: 220 – 240 V CA



Esta clavija sólo es compatible con una toma de corriente con conexión a tierra. Si no puede insertar la clavija en la toma de corriente, póngase en contacto con un electricista para instalar la toma adecuada. No haga nada que vaya en contra de los fines de seguridad de la clavija con toma a tierra.

- Este producto debe utilizarse exclusivamente con el tipo de fuente de alimentación indicado en la etiqueta. Ante cualquier duda sobre el tipo de alimentación de su hogar, consulte al concesionario donde adquirió el producto o a la compañía de electricidad de su zona.

Advertencia:

- No emplee el mismo cable de alimentación para 120 V CA y para 220 – 240 V CA. Hacerlo puede producir un fallo, choques eléctricos o incendio.

Nota sobre el cable de alimentación para el Reino Unido solamente

La clavija del cable de alimentación para el Reino Unido cuenta con un fusible incorporado. Cuando reemplace el fusible, asegúrese de emplear uno del amperaje y tipo aprobados y coloque la cubierta del fusible. (Consulte con su concesionario o personal de servicio cualificado).

Método para reemplazar el fusible

Abra el compartimiento del fusible con un destornillador de punta plana y reemplace el fusible.

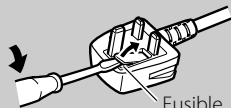

- Antes de conectar otros productos tales como videograbadoras (VCRs) y ordenadores, deberá desconectar la alimentación de este producto para protegerlo contra las descargas eléctricas.
- No utilice accesorios no recomendados por el fabricante, pues podrá ser peligroso.
- **Siempre que se requiera reemplazar alguna pieza,** asegúrese de que el técnico de servicio utilice los repuestos especificados por el fabricante o sus equivalentes. El uso de piezas no autorizadas puede provocar incendios, descargas eléctricas, y otros peligros.
- **Al término de cualquier servicio o reparación de este producto,** pida al técnico que realice las verificaciones de seguridad, para comprobar su correcto funcionamiento.

- Evite instalar este producto en los siguientes lugares:
 - en lugares húmedos o polvorientos
 - donde el producto esté expuesto al vapor u hollín, como cerca de una cocina o un humidificador
 - cerca de fuentes de calor
 - donde pueda ocurrir la condensación, como cerca de un ventana
 - en un lugar expuesto a la luz directa del sol o a una luz intensa
- No ponga este producto sobre carros, soportes o mesas inestables. La caída del producto puede causar lesiones graves a la gente que está alrededor (niños y adultos), e incluso producir daños de gravedad al producto. Instale el producto de acuerdo con las instrucciones del fabricante, y utilice una montura recomendada por el fabricante.
- No utilice este producto cerca del agua.
- Asegúrese de instalar el producto en un lugar donde se mantengan las condiciones de temperatura y humedad adecuadas (ver "Condiciones de funcionamiento" en la página 45). Este producto puede calentarse durante el uso. Maneje este producto con cuidado.

En las siguientes condiciones,

1. **Apague el sistema.**
2. **Desenchufe el producto del tomacorriente.**
3. **Deje el mantenimiento a personal de servicio cualificado.**
 - a) Cuando el producto emite humos u olores extraños.
 - b) Cuando el producto presente cambios notables en el funcionamiento—por ejemplo, no hay imagen o sonido.
 - c) En caso de haberse derramado líquido o de haberse caído algún objeto dentro del producto.
 - d) Si se ha expuesto el producto a la lluvia o al agua.
 - e) Si se ha dejado caer o se ha dañado el producto.
 - f) Cuando se ha dañado el cable de alimentación o el enchufe.

Jamás intente reparar este producto por su cuenta, ya que si abre o desmonta las cubiertas, puede quedar expuesto a descargas de tensión y otros peligros. Deje todo el mantenimiento a personal de servicio cualificado.

No utilice el producto por un tiempo prolongado si el sonido está distorsionado.

Utilice sólo la fuente de alimentación especificada en la unidad.
• Alimentación de CA: 120 V/220 V – 240 V, 50 Hz/60 Hz

- La fuente de alimentación de CA se controla mediante la activación/desactivación del interruptor POWER en el panel trasero. Si el producto se instala en un lugar donde no es sencillo conectar/desconectar el interruptor POWER, controle el suministro de energía de CA enchufando/desenchufando el cable de alimentación en/de la toma de CA. En este caso, instale el producto lo más cerca posible de la toma de CA, y procure que haya un espacio libre suficiente para enchufar/desenchufar el cable de alimentación. Si el producto se instala en un lugar donde no es sencillo enchufar y desenchufar el cable de alimentación, instale en el cableado del edificio un dispositivo de fácil acceso para activar y desactivar la alimentación.
- Cuando deje el producto desatendido o sin usar durante mucho tiempo, desenchúfelo del tomacorriente y desconecte el sistema de cables.
- No enchufe demasiados aparatos en los enchufes, cables prolongadores o tomacorrientes supletorios de otros equipos, ya que podrían producirse incendios o descargas eléctricas.
- Para evitar descargas eléctricas, utilice solamente el cable de accesorio diseñado para este producto.

- Se han provisto ranuras y aberturas de ventilación en el gabinete. Tienen por objeto asegurar una operación confiable y evitar el recalentamiento. Estas aberturas no deben ser tapadas ni cubiertas.
- No introduzca ningún tipo de objeto a través de las ranuras o aberturas del producto, ya que podrían entrar en contacto con puntos de tensión peligrosos u ocasionar un cortocircuito en las piezas, lo cual podría causar a su vez descargas eléctricas o incendios.
- Tenga cuidado de no derramar líquidos de ningún tipo sobre el producto.
- Nunca deje objetos encima del producto. (Los líquidos, llamas, prendas, papel, etc., colocados sobre el producto podrían ocasionar un incendio).
- Evite aplicar golpes fuertes al panel LCD. (No lo golpee con ningún objeto ni lo empuje con una herramienta puntiaguda).
- No ponga objetos pesados sobre el producto.
- No se suba ni se cuelgue de este producto.

ADVERTENCIA

Para evitar lesiones mediante una caída accidental

Utilice cuerdas para fijar el monitor a la pared.

Fijación del monitor

Fije el gancho (no suministrado) en los orificios de montaje VESA del panel trasero (utilice los dos orificios del lado superior) utilizando tornillos M4 x 10 mm (no suministrados). Fije los ganchos de la parte trasera del monitor a la pared o un pilar mediante una cuerda resistente.

Orificios de montaje VESA

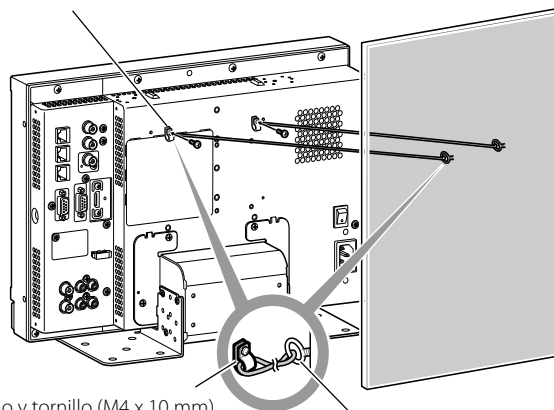

Gancho y tornillo (M4 x 10 mm)
(no suministrados)

Gancho (no suministrado)

Precauciones de seguridad (cont.)

Sólo Unión Europea

Estimado cliente,

Este aparato cumple con las directivas y normas europeas válidas sobre compatibilidad electromagnética y seguridad eléctrica.

El representante para Europa de JVC KENWOOD Corporation es:
JVC Technical Services Europe GmbH
Postfach 10 05 04
61145 Friedberg
Alemania

Información para los usuarios sobre la eliminación de equipos usados



[Unión Europea]

Este símbolo indica que los aparatos eléctricos y electrónicos no deben desecharse junto con la basura doméstica al final de su vida útil. El producto deberá llevarse al punto de recogida correspondiente para el reciclaje y el tratamiento adecuado de equipos eléctricos y electrónicos de conformidad con la legislación nacional.

Atención:

Este símbolo sólo es válido en la Unión Europea.

Si desecha el producto correctamente, estará contribuyendo a conservar los recursos naturales y a prevenir los posibles efectos negativos en el medio ambiente y en la salud de las personas que podría causar el tratamiento inadecuado del producto desechado. Para

obtener más información sobre el punto de recogida y el reciclaje de este producto, póngase en contacto con su oficina municipal, su servicio de recogida de basura doméstica o la tienda en la que haya adquirido el producto.

Para obtener más información sobre el punto de recogida y el reciclaje de este producto, póngase en contacto con su oficina municipal, su servicio de recogida de basura doméstica o la tienda en la que haya adquirido el producto.

(Empresas)

Si desea desechar este producto, visite nuestra página Web <http://www.jvc.eu/> para obtener información acerca de la retirada del producto.

[Otros países no pertenecientes a la Unión Europea]

Si desea desechar este producto, hágalo de conformidad con la legislación nacional vigente u otras normativas de su país para el tratamiento de equipos eléctricos y electrónicos usados.

Suplemento de EMC

Este equipo cumple con las provisiones y los requisitos de protección de las correspondientes Directivas Europeas. Este equipo ha sido diseñado para aparatos de vídeo profesional y puede utilizarse en los siguientes entornos:

- Entorno controlado de EMC (por ejemplo, estudio de grabación o difusión de propósito especial), y entornos rurales exteriores (alejados de ferrocarriles, transmisores, líneas aéreas eléctricas, etc.)

Para optimizar el rendimiento y asegurar compatibilidad electromagnética, se recomienda el uso de cables que no excedan la siguiente longitud:

Cable	Longitud
Cordón de alimentación (cable adjunto (H05VV-F 3 x 0,75 mm ²))	2,0 m
Cable de señal de vídeo (cable coaxial)	2,0 m
Cable de señal de audio (cable blindado)	1,5 m
Cable HDMI (cable blindado)	2,0 m
Cable DVI (cable blindado) con filtro de núcleo	2,0 m
Cable RS-232C (cable blindado) (Un cable recto con un conector D-sub de 9 patillas)	2,0 m
Cable RS-485 (cable de pares trenzados) (Un cable LAN recto)	2,0 m
Cable REMOTE (cable de pares trenzados) (Un cable LAN recto)	2,0 m
Cable RGB VGA (cable blindado)	2,0 m

La corriente de irrupción de este aparato es de 4,24 amperios.

PRECAUCIÓN

En el caso de haber fuertes ondas electromagnéticas o magnetismo cerca del cable de audio o del cable de señales, el sonido o la imagen contendrá ruido. En tales casos, por favor mantenga el cable alejado de las fuentes de perturbaciones.

Меры предосторожности



CAUTION
RISK OF ELECTRICAL SHOCK
DO NOT OPEN



CAUTION: To reduce the risk of electric shock. Do not remove cover (or back). No user serviceable parts inside. Refer servicing to qualified service personnel.

The lightning flash with arrowhead symbol, within an equilateral triangle is intended to alert the user to the presence of uninsulated "dangerous voltage" within the product's enclosure that may be of sufficient magnitude to constitute a risk of electric shock to persons.

The exclamation point within an equilateral triangle is intended to alert the user to the presence of important operating and maintenance (servicing) instructions in the literature accompanying the appliance.

ПРЕДУПРЕЖДЕНИЕ: ДЛЯ СНИЖЕНИЯ РИСКА ВОСПЛАМЕНЕНИЯ ИЛИ ПОРАЖЕНИЯ ЭЛЕКТРИЧЕСКИМ ТОКОМ НЕ ПОДВЕРГАЙТЕ ДАННОЕ УСТРОЙСТВО ВОЗДЕЙСТВИЮ ДОЖДЯ ИЛИ ВЛАГИ. НЕ ДОПУСКАЕТСЯ РАЗМЕЩЕНИЯ КАКИХ-ЛИБО ЕМКостей, НАПОЛНЕННЫХ ЖИДКОСТЯМИ, ТАКИХ КАК ВАЗЫ, НА УСТРОЙСТВЕ.

Предупреждение: Данное изделие относится к устройствам класса А. В этом случае пользователю изделия, возможно, потребуется принять соответствующие меры.

МЕРЫ БЕЗОПАСНОСТИ

Электрическая энергия может выполнять множество полезных функций. Этот электроприбор спроектирован и изготовлен с соблюдением требований к Вашей личной безопасности. Однако **НЕПРАВИЛЬНАЯ ЭКСПЛУАТАЦИЯ МОЖЕТ ПРИВЕСТИ К ПОРАЖЕНИЮ ЭЛЕКТРИЧЕСКИМ ТОКОМ ИЛИ ПОЖАРУ.** Чтобы не нарушить работу предохранителей, встроенных в это изделие, руководствуйтесь при его установке, использовании и обслуживании следующими основными правилами. Перед началом использования внимательно прочитайте раздел "МЕРЫ БЕЗОПАСНОСТИ".

- Перед началом использования изделия необходимо ознакомиться со всеми требованиями техники безопасности и инструкциями.
- Необходимо сохранить требования техники безопасности и инструкции для обращения к ним в будущем.
- Необходимо учитывать все предупреждающие знаки на изделии и предупреждения в инструкциях по эксплуатации.
- Необходимо следовать всем инструкциям.

ПОДКЛЮЧЕНИЕ ПИТАНИЯ

Этот прибор рассчитан на входное напряжение 120 В переменного тока (только для США и Канады) и 220 – 240 В переменного тока (для стран Европы, стран Азии и Великобритании). Подсоединенный шнур питания соответствует следующему региональному стандарту и рассчитан на следующее напряжение. Используйте только шнур питания, изготовленный в соответствии с правилами техники безопасности и положениями EMC для Вашей страны.

- Не все типы шнуров питания прилагаются в комплекте поставки данного изделия.

США и Канада: 120 В переменного тока	Для стран Европы и Азии: 220 – 240 В переменного тока	Для Великобритании: 220 – 240 В переменного тока
--------------------------------------	---	--



Эта вилка подходит только для заземленной розетки. Если невозможно вставить вилку в розетку, обратитесь к электрику для установки розетки необходимого типа. В целях безопасности не пренебрегайте вилкой с заземлением.

- Это изделие можно подключать к источнику питания только такого типа, который указан на ярлыке. Если Вы не знаете, какой тип электрических розеток используется в Вашем доме, обратитесь к своему поставщику или в местную компанию электроснабжения.

Предупреждение:

- Не используйте одинаковые шнуры питания для 120 В и 220 – 240 В переменного тока. Это может привести к неисправности изделия, поражению электрическим током или пожару.

Примечание только для шнура питания для Великобритании
Вилка шнура питания, предназначенного для Великобритании, оснащена встроенным предохранителем. Для замены предохранителя используйте только предохранитель надлежащего типа. После замены верните крышку предохранителя в исходное положение. (Обратитесь к своему поставщику или квалифицированному электрику.)

Замена предохранителя

Откройте отделение предохранителя шлицевой отверткой и замените предохранитель.

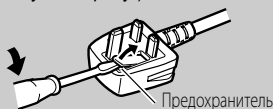

- Перед подключением других изделий, например видеомэгагитофонов и персональных компьютеров, необходимо отключить питание данного изделия во избежание поражения электрическим током.
- Не используйте принадлежности, которые не были рекомендованы изготовителем, поскольку они могут быть опасными.
- **Если требуется замена деталей,** убедитесь в том, что специалист по сервисному обслуживанию использует детали, указанные изготовителем, или эквивалентные им. Использование несанкционированных деталей может привести к воспламенению, поражению электрическим током или другой чрезвычайной ситуации.
- **После завершения сервисного обслуживания или ремонта этого изделия всегда требуйте от специалиста по сервисному обслуживанию проведения проверки на безопасность,** чтобы убедиться в том, что изделие находится в нормальном рабочем состоянии.

- Не устанавливайте изделие в следующих местах:
 - в пыльном или загрязненном помещении;
 - в помещениях, где изделие подвергается воздействию копоти или пара, например рядом с плитой или увлажнителем;
 - рядом с источниками тепла;
 - в местах скопления конденсата, например рядом с окном
 - в местах, подверженных воздействию прямых лучей солнечного света или сильного света
- Не ставьте это изделие на неустойчивые тележки, подставки и столы. Изделие может упасть и причинить тяжелые травмы ребенку или взрослому человеку или серьезно повредиться. Монтаж изделия следует производить в соответствии и инструкциями изготовителя с использованием крепежных деталей, рекомендованных изготовителем.
- Не используйте изделие рядом с водой.
- Устанавливайте изделие в месте, где поддерживаются надлежащие температура и влажность (☞ "Условия эксплуатации" на стр. 45). В процессе использования это изделие может нагреваться. Будьте осторожны при работе с изделием.

При возникновении любого из перечисленных условий выполните следующие действия:

1. **Выключите питание.**
2. **Отключите прибор от настенной розетки.**
3. **Обратитесь за помощью к квалифицированному специалисту по сервисному обслуживанию.**
 - a) Если из прибора идет дым или ощущается непривычный запах.
 - b) Если рабочие характеристики изделия заметно изменились, — например отсутствует изображение или звук.
 - c) Если на изделие попали брызги или упал какой-либо предмет.
 - d) Если изделие находилось под дождем или подверглось воздействию влаги.
 - e) В случае падения или другого повреждения изделия.
 - f) Если поврежден шнур питания или разъем.

Меры предосторожности (продолж.)

Не пытайтесь выполнять сервисное обслуживание самостоятельно, поскольку, сняв корпус, Вы подвергнете себя опасности воздействия высоких напряжений и других опасных факторов. Поручите сервисное обслуживание квалифицированному специалисту.

Не используйте изделие в течение длительного времени, когда звук искажен.

Используйте только источник питания, указанный на устройстве.

- Переменный ток: 120 В/220 - 240 В, 50 Гц/60 Гц

- Питание переменным электрическим током управляется включением/выключением выключателя питания POWER, расположенного на задней панели. Если изделие установлено в месте, где сложно включать/выключать переключатель POWER, управляйте включением/выключением питания подключая/отсоединяя вилку шнура питания к/от розетки питания переменного тока. В этом случае установите изделие как можно ближе к розетке сети переменного тока и оставьте достаточно места для подсоединения/отсоединения шнура питания. Если изделие установлено в месте, где непросто отсоединять/подсоединять шнур питания, оборудуйте проводку помещения легко доступным устройством для включения/выключения электропитания.
- Если изделие не будет использоваться в течение длительного времени, отключите его от настенной розетки и отсоедините кабельную систему.
- Не перегружайте настенные розетки, удлинители и дополнительные розетки на другом оборудовании, поскольку это может стать причиной воспламенения или поражения электрическим током.
- Во избежание поражения электрическим током используйте только шнур, входящий в комплект и предназначенный для данного изделия.

- Прорези и отверстия в корпусе предназначены для вентиляции. Они обеспечивают стабильную работу изделия и предохраняют его от перегрева. Нельзя закрывать эти отверстия.
- Не вставляйте никакие предметы внутрь изделия через отверстия, поскольку они могут соприкоснуться с деталями, находящимися под высоким напряжением, или вызвать короткое замыкание, что может стать причиной воспламенения или поражения электрическим током.
- Оберегайте изделие от попадания на него любых видов жидкости.
- Никогда ничего не ставьте на изделие сверху. (Размещение на изделии сосудов с жидкостями, источников открытого огня, предметов из ткани или бумаги и т.п. может привести к воспламенению и пожару.)
- Не подвергайте ЖК-панель сильным механическим воздействиям. (Не ударяйте изделие и не давите на него заостренными предметами.)
- Не ставьте на изделие тяжелые предметы.
- Не вставляйте и не облокачивайтесь на изделие.

ПРЕДУПРЕЖДЕНИЕ

В целях предотвращения травм в результате случайного падения

Прикрепите монитор к стене с помощью шнуров безопасности.

Крепление монитора

Закрепите крюки (не прилагаются) в крепежных отверстиях стандарта VESA на задней панели (используйте два отверстия в верхней части) с помощью винтов M4 x 10 мм (не прилагаются). Привяжите крюки на задней панели монитора к креплению на стене или к столбу прочным шнуром.

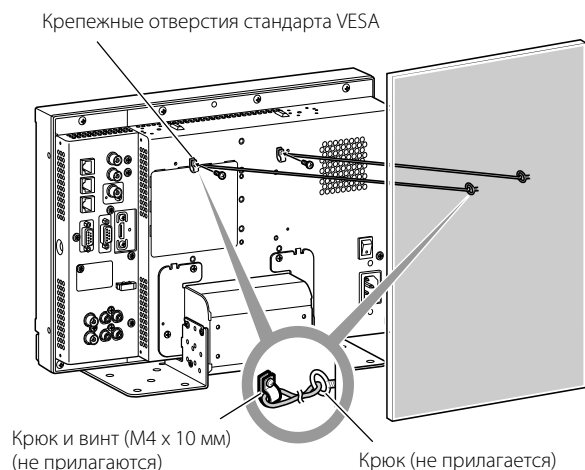

Уважаемый покупатель,

Данное устройство отвечает требованиям действующих Директив и стандартов ЕС относительно электромагнитной совместимости и электрической безопасности.

Европейский представитель компании JVC KENWOOD Corporation:
JVC Technical Services Europe GmbH
Postfach 10 05 04
61145 Friedberg
Germany (Германия)

Информация для пользователей, выбрасывающих старое оборудование



[Европейский Союз]

Это символ указывает, что после окончания срока службы соответствующего электрического или электронного оборудования, нельзя выбрасывать его вместе с обычным бытовым мусором. Вместо этого, оно подлежит сдаче на утилизацию в соответствующий пункт приема электрического и электронного оборудования для последующей переработки и утилизации в соответствии с национальным законодательством.

Обеспечивая правильную утилизацию данного изделия, Вы помогаете сберечь природные ресурсы и предотвращаете

Внимание:

Действие этого символа распространяется только на Европейский Союз.

Ущерб для окружающей среды и здоровья людей, который возможен в случае ненадлежащего обращения с изделием. Более подробную информацию о пунктах приема и утилизации данного изделия можно получить в местных муниципальных органах, на предприятии по вывозу бытового мусора или по месту приобретения изделия.

Нарушение правил утилизации данного типа отходов может повлечь наказание в соответствии с национальным законодательством.

(Организации-пользователи)

Если Вы желаете избавиться от данного изделия, посетите нашу веб-страницу <http://www.jvc.eu/> и ознакомьтесь с информацией о приемке производителем отработанных изделий.

[Страны, не входящие в Европейский Союз]

Если Вы собираетесь выбросить данный продукт, руководствуйтесь национальным законодательством или другими правилами, действующими в Вашей стране по отношению к переработке старого электрического и электронного оборудования.

Дополнение в отношении электромагнитной совместимости

Данное оборудование отвечает положениям и требованиям безопасности соответствующих Директив ЕС. Данное оборудование разработано для профессиональных видеоприборов и может использоваться в следующих окружающих условиях:

- В условиях контролируемой EMC (например, специально построенные вещательные или записывающие студии), в условиях использования вне помещений в сельской местности (вдали от железнодорожного полотна, передатчиков, воздушных линий электропередачи и т. д.)

С целью поддержания высоких эксплуатационных характеристик и обеспечения электромагнитной совместимости, рекомендуется использовать кабели, длина которых не превышает следующие значения:

Кабель	Длина
Шнур питания (подсоединенный кабель (H05VV-F 3 x 0,75 мм ²))	2,0 м
Кабель передачи видеосигналов (коаксиальный кабель)	2,0 м
Кабель передачи аудиосигналов (экранированный кабель)	1,5 м
Кабель HDMI (экранированный кабель)	2,0 м
Кабель DVI (экранированный кабель), оснащенный фильтром с сердечником	2,0 м
Кабель RS-232C (экранированный кабель) (Прямой кабель с D-sub 9-контактным соединительным разъемом.)	2,0 м
Кабель RS-485 (кабель с витой парой) (Прямой сетевой кабель)	2,0 м
Кабель REMOTE (кабель с витой парой) (Прямой сетевой кабель)	2,0 м
Кабель RGB VGA (экранированный кабель)	2,0 м

Пусковой ток данного устройства составляет 4,24 ампера.

ПРЕДОСТЕРЕЖЕНИЕ

Наличие сильных электромагнитных волн или магнитного поля вблизи аудиокабеля или кабеля, передающего сигналы, может вызывать помехи и искажения в звуке или в картинке. В подобных случаях держите кабель вдали от источников помех.

使用前的安全注意事项



CAUTION
RISK OF ELECTRICAL SHOCK
DO NOT OPEN



警告 为了减少火灾和触电的危险。切勿打开盖板（或后盖）。本机内部没有用户可自行维修的零件。所有维修工作应由有资格的人员完成。



等边三角形内带箭头的闪电标记警示用户附件中存在未绝缘的“危险电压”，可能足够对人体造成电击。



等边三角形内叹号标记警示用户重要的操作和维护（服务）说明书已随装置附带。

警告： 为了减少火灾和触电的危险，切勿让本机受雨淋或潮湿。勿在机体的上面放置盛满液体的容器，如花瓶。

警告： 本产品为 A 级产品。使用本品可能会产生无线电干扰，使用者须采取适当措施。

重要的安全措施

利用电能可以产生许多有用的功能。本机经精心设计和制造，能够保证您的人身安全。但是不当使用会引起电击或火灾。为了不损坏本机内部的安全装置，请遵守本机在安装、使用及维修时的以下基本规则。请在使用前仔细阅读“重要的安全措施”。

在使用本产品之前，须仔细阅读有关安全和操作的所有说明。

安全和操作说明书须妥善保存，以便将来参考之用。本产品上和使用说明书中的警告均须严格遵守。必须按照所有的说明进行操作。

- 在连接例如录像机和个人电脑等其他产品之前，您必须关闭本产品的电源以防止电击。
- 切勿使用生产商不推荐的附件，因为它们可能会有危险。
- 当需要更换部件时，确保技师使用了生产商规定的更换部件或同等物。未经许可的更换物可能会引起火灾，电击或其他危险。
- 关于本产品任何服务和维修的实行，询问技师后完成安全检测以确定本产品运作正常。

电源的连接

本产品的额定电压为 AC 120 V（对应美国和加拿大）和 AC 220 – 240 V（对应欧洲，亚洲国家和英国）。附带的电源线与以下的供电电压和国家相一致。仅使用指定的电源线以确保安全和 EMC 法规。

• 本产品不附带所有类型的电源线。

对应美国和加拿大： AC 120 V 对应欧洲和亚洲国家： AC 220 – 240 V 对应英国： AC 220 – 240 V

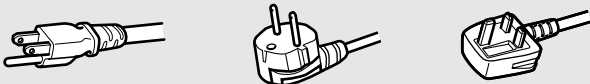

这个插头只能插入接地的电源插座。如果您不能将插头插入插座，请联系电工安装合适的电源插座。不要使接地插头失去其安全功效。

• 本产品需使用标签上标明的电源类型进行操作。如果您不确定您当地的电源类型，向您的产品经销商或当地的供电公司咨询。

警告：

• 切勿对应 AC 120 V 和 AC 220 – 240 V 使用相同的电源线。这样做可能引起故障，短路或火灾。

仅对应英国电源线的注意事项

英国的电源线插头具有内置保险丝。更换保险丝时，确保使用合格的额定电压正确的型号，并重新固定保险丝盒盖。

（请咨询经销商或专业人员。）

如何更换保险丝

使用叶片螺旋刀打开保险丝盒并更换保险丝。

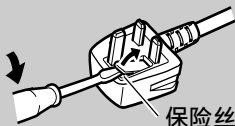

- 切勿将本机安装在以下环境中：
 - 潮湿或多尘房间内
 - 将本机暴露于油烟或蒸汽环境中，如靠近厨房或加湿器
 - 靠近热源
 - 容易发生结露的环境，如靠近窗户的地方
 - 暴露于直射阳光或强光的位置
- 切勿将本产品置于不稳定的台车，架子或桌子上。否则本产品可能会翻倒，从而导致儿童或成人受伤并使本产品遭到严重破坏。须按照厂家的说明安装本产品并使用厂家所推荐的机架。
- 请勿在水附件使用本产品。
- 确保将本产品安装在保持适当温度和湿度的地方（第 45 页上的“操作状态”）。本机在使用过程中会发热。使用本产品时请足够小心。

在下列情况下，

1. 关闭电源。
2. 将本机与墙壁插座断开连接。
3. 请向专业人员咨询。
 - a) 当本机冒烟或发出异味。
 - b) 当本机在性能上有明显变化时——例如，无图像或无声音。
 - c) 如果有液体溅在本产品上或有物体砸在本产品上时。
 - d) 如果本机受了雨淋或受潮时。
 - e) 如果本机因摔落或其他原因受损。
 - f) 当电源线或插头破损时。

请勿试图自己维修本产品。否则，打开或拆下机壳时可能会触及危险的电压或发生其他危险。所有服务请向专业人员咨询。

如果声音失真，切勿长时间使用本产品。

使用本机上标明的电源。

• 交流电源：120 V/220 - 240 V，50 Hz/60 Hz

- 交流电源由打开/关闭后面板上的 POWER 开关控制。如果本产品安装在无法方便地打开/关闭 POWER 开关的地方，从交流电源插座插入/拔开电源线来控制交流电源。此种情况下，在尽可能靠近交流电源插座的位置安装本产品，并为插入/拔开电源线留足空间。如果本产品安装在无法方便地插入/拔开电源线的地方，安装一个便于操作的装置至建筑的线路来启动/关闭电源。
- 当本机暂不使用时或长期不使用时，请从墙上电源插座拔下本机的插头并断开电缆系统。
- 切勿使墙上电源插座、延长导线或其他装置的方便插座等过载，否则会导致火灾或触电的危险。
- 为防止触电，请仅使用本产品附带的专用导线。

- 机壳上的槽和开口用于通风。它们保证了本产品的可靠的操作性能，并可防止本机过热。这些开口不可被堵塞或盖住。
- 在任何情况下不要将物品推入本品的开口处，推入物可能会触到危险电压点或造成部件短路引起火灾或触电。
- 避免将任何液体溅在本品上。
- 避免在本品上放置任何东西。（在本品上放置液体，明火，布料和纸张等可能会引起火灾。）
- 切勿猛然晃动 LCD 面板。（切勿使用任何物体砸它或尖角工具戳它。）
- 切勿在本机上放置重物。
- 切勿践踏本机或在本机上悬挂物件。

警告

为防止因突然掉落而造成的伤害
使用绳子将监视器固定至墙壁。

固定监视器

使用 M4 x 10 mm 的螺丝（另购）连接钩子（另购）至后面板上的 VESA 安装孔（使用上面的两个孔）。使用耐用的绳子连接监视器后面板上的钩子至墙壁或柱子。

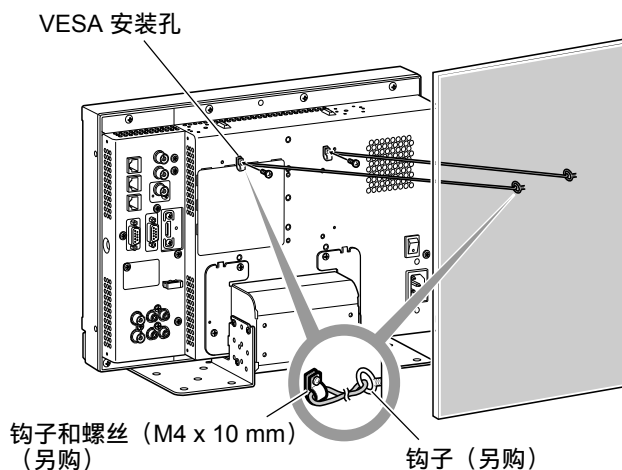

使用前的安全注意事项（续）

仅对应欧洲联盟

亲爱的顾客，

本装置符合欧洲有效的关于电磁兼容性和用电安全的规定和标准。

JVC KENWOOD Corporation 的欧洲代表处是：

JVC Technical Services Europe GmbH

Postfach 10 05 04

61145 Friedberg

德国

用户旧设备处理信息



[欧盟国家]

此符号表示，在电气和电子设备使用寿命结束时，不应将其当作一般家庭废弃物进行处理。而是要按照您所在国家的法律，将电气和电子设备送交适合的收集点进行回收处理。

通过正确处理此产品，可以保护自然资源，防止对环境和人体健康造成潜在不良影响。有关收集点和产品回收的详情，请联系本地市政办公室、家庭废弃物处理服务中心或购买本产品的商店。

按照国家法律，不正确处理此废弃物可能会

受到处罚。

（商业用户）

如果您要处理本产品，请访问我们的网站 <http://www.jvc.eu/>，以获得关于产品返还的信息。

[欧盟以外的其他国家]

如果您要处理本产品，请按照您所在国家有关处理旧电气和电子设备的法律或其他法规进行处理。

EMC 补充条款

本设备符合相应的欧洲规定的条款和保护要求。本设备用于专业的视频机器并能够用于以下环境：

控制的 EMC 环境（例如专门建造的广播和录音室）和乡村的户外环境（远离铁路和架空电力线路等）

为了保持最好的性能并确保电磁兼容性，建议使用不超过以下长度的电缆：

电缆	长度
电源线 （附带的电缆（H05VV-F 3 x 0.75 mm ² ））	2.0 m
视频信号电缆（同轴电缆）	2.0 m
音频信号电缆（屏蔽电缆）	1.5 m
HDMI 电缆（屏蔽电缆）	2.0 m
带有绕线过滤芯的 DVI 电缆（屏蔽电缆）	2.0 m
RS-232C 电缆（屏蔽电缆） （带有 D-sub 9-针连接器的直线电缆）	2.0 m
RS-485 电缆（对绞电缆） （直线 LAN 电缆）	2.0 m
REMOTE 电缆（对绞电缆） （直线 LAN 电缆）	2.0 m
RGB VGA 电缆（屏蔽电缆）	2.0 m

本装置的起动电流为 4.24 安培。

注意

如果强电磁波或磁力在音频电缆或信号电缆附近，声音或图像会含有噪音。此种情况下，请使电缆远离干扰源。

Operating Precautions

The LCD panel and backlight have life expectancy. Due to the basic characteristics of the LCD panel, an afterimage or uneven display may occur. It is recommended that you change images occasionally, activate the power saving function, or often turn off the power to reduce the load on the LCD panel. Continuous operations of the LCD panel may accelerate the deterioration.

● Caution for use of the product for many hours

In the case that you use the monitor for many hours, we recommend that you set "No Sync Action" in "Sync Function" to "Power Save" in Main Menu. This will reduce power consumption and relieve strain on the monitor. To reduce damage to the LCD panel, using the LCD Saver function is recommended.

● Caution for use of the product in the high temperature

Do not use the product in places of high temperature; otherwise, parts of this product or the LCD panel may be damaged. This product is equipped with a temperature sensor to give warning if the temperature becomes too high. If the temperature exceeds the range of normal use, "Temp. Over" is displayed, and the power is turned off automatically if the temperature becomes any higher. In this case, move the product to a place of low temperature to let it cool down.

● Maintenance

Unplug this product from the wall outlet before cleaning.

LCD panel

To avoid irreparable change in appearance of the screen such as uneven color, discoloration, scratches, be careful about the following:

- Do not paste or stick anything using any glues or adhesive tapes.
- Do not write anything on the screen.
- Do not strike the screen with a hard object.
- Avoid condensation on the screen.
- Do not wipe the screen with any liquid such as water. In addition, wiping the screen with water-diluted neutral detergent or solvent such as alcohol, thinner, or benzine may affect the anti-reflection treatment of the screen.
- Do not wipe the screen forcefully.

Wipe stains off the LCD panel with a soft cloth. If the screen gets heavily stained, wipe it with a soft cloth soaked in water-diluted neutral detergent and wrung well, then wipe with a soft dry cloth.

Cabinet

To avoid the deterioration or damages of the cabinet such as its paint's peeling away, be careful about the following:

- Do not wipe the cabinet using solvent such as alcohol, thinner, or benzine.
- Do not expose the cabinet to any volatile substance such as insecticides.
- Do not allow any rubber or plastic in contact for a long time.
- Do not wipe the cabinet forcefully.

Wipe stains off the cabinet with a soft cloth. If the cabinet gets heavily stained, wipe it with a soft cloth soaked in water-diluted neutral detergent and wrung well, then wipe with a soft dry cloth.

Ventilation openings

Use a vacuum cleaner to get rid of the dust around the intakes (all the openings). If a vacuum cleaner is not available, use a cloth and wipe it off. Leaving the dust around the intakes may prevent proper temperature control and cause damage to the product.

Table of Contents

Safety Precautions.....	2	Volume Adjustment/Audio Channel Selection	29
Sicherheitsmaßregeln.....	5	On the Information Display	29
Précautions de sécurité.....	8	On the Status Display	29
Precauzioni di sicurezza	11	Menu Configuration	30
Precauciones de seguridad.....	14	First Time Installation	30
Меры предосторожности.....	17	The operation procedure	30
使用前的安全注意事项	20	Menu Transition Diagram	31
Operating Precautions	23	Main Menu	32
Caution for use of the product for many hours	23	Set-Up Menu	36
Caution for use of the product in the high temperature	23	External Control	40
Maintenance	23	About the external control	40
Installation	24	Using the Make/Trigger system	40
Index of Parts and Functions.....	26	Using the serial communication	41
Rear panel	26	Troubleshooting	43
Front panel	28	Self-check program	44
Showing Input Signals.....	29	Specifications.....	45
		General	45
		LCD panel	45
		Input/output terminals	45
		Dimensions	46
		Available signals	47
		Краткое руководство пользователя ...	49

Installation

- Do not rest your arm on the monitor or lean against the monitor.
- Do not touch the LCD panel when installing the monitor.
- Be sure to install the monitor securely to prevent the monitor from falling over, which may cause damage to the monitor or injury.

● To install the monitor on a shelf or any other suitable surface using screws

You can install the monitor without protruding the stand bottom plate by moving the stand bottom plate to the rear position.

CAUTION

- Lay the monitor on a cloth with the LCD panel facing down to prevent the LCD panel from being damaged.
- After moving the stand bottom plate to the rear position, be sure to attach the stand with commercially available screws.

1 Loosen the stand screws on the stand support and remove the bottom plate.

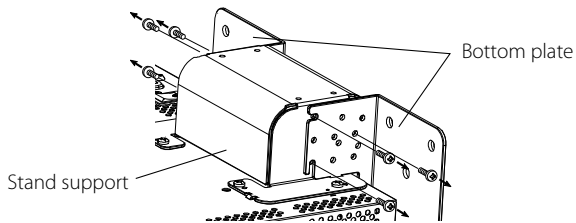

2 Temporarily set the stand screws to screw holes "3" on the right and left sides of the stand support.

- Tighten the temporarily set stand screws so that they protrude from the screw holes by about 4 mm.

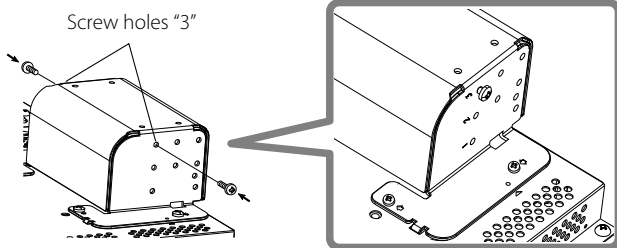

3 Hook right and left recesses "A" onto the temporarily set screws in the stand support.

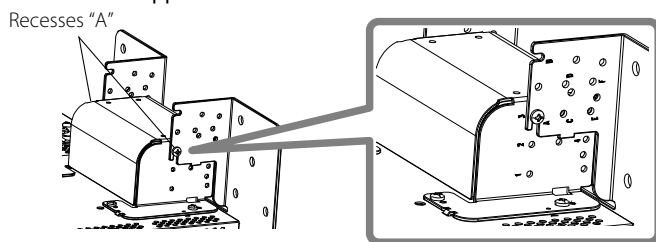

4 Adjust the position so that the screw holes on the stand support align with right and left screw holes "C" and "E" on the bottom plate, tighten the two stand screws on one side (four screws on both sides), and finally retighten the temporarily set screws to lock the stand support and the bottom plate.

Screw holes "C" and "E"

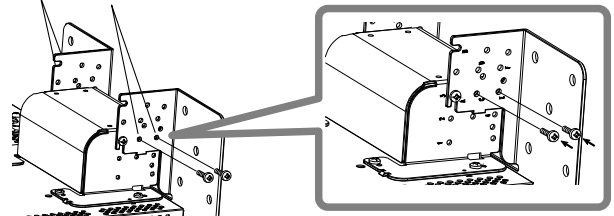

5 Use no less than two commercially available screws (no less than four screws on both sides) for the screw holes (10 - φ8) on the stand bottom plate, to anchor the monitor.

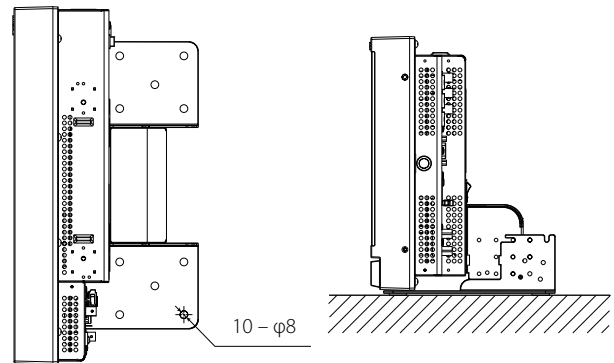

CAUTION

- Use screws having enough holding strength and resistance against external force of expected vibrations.
- It is very dangerous not to anchor the stand with screws as this may cause not only breakage due to the monitor falling or dropping, but also injury or electrical shock.

● To detach the stand

CAUTION

- Lay the monitor on a cloth with the LCD panel facing down to prevent the LCD panel from being damaged.

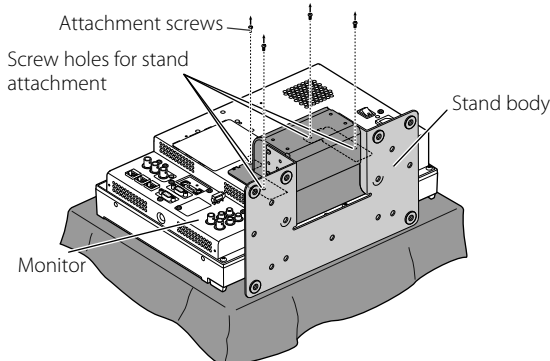

● To install the stand

When attaching the stand to the monitor, insert the guides of the stand into the guide holes on the monitor to place the stand in the correct position. Then fix the stand firmly with the attachment screws.

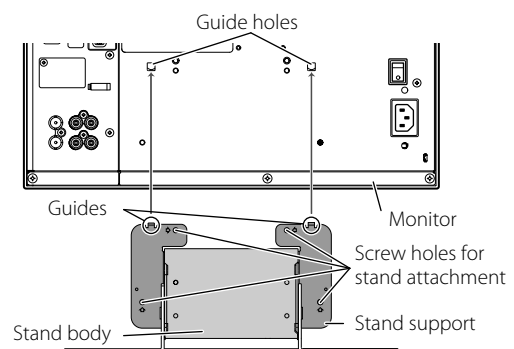

● **To install the monitor on a wall**

You can install the monitor on a wall by changing how the stand bottom plate is attached.

Installation Only for Authorized Service Personnel

Consult authorized service personnel for the installation of this unit.

Installation instructions must be followed precisely in order to prevent accidents.

We are selling this product with the understanding that it will be assembled and installed by properly trained and qualified service personnel.

About Accidents/Damages

We are not liable for any damage caused by faulty assembly, faulty wall mounting, insecure wall mounting, misuse, alterations, or natural disasters.

- Please be aware that screw holes and anchor bolts will remain in the wall surface if the monitor is removed after having been mounted to the wall.
- Long-term use of the monitor may result in discoloration of the wall surface due to heat/air emitted by the monitor.

! Danger

- Consult authorized service personnel for the installation and attachment of this unit to the wall. Do not attempt to mount the unit by yourself.
- Improper assembly or installation may cause the unit to fall when it is mounted, which may result in fatal accidents.
- To prevent this happening, check the strength of the materials in the mounting surface. Check the material strength again after mounting as well.

! Warning

- Using a monitor other than this product may result in damage or bodily injury due to the monitor toppling over.
- Assemble all screws securely. Failure to do so may result in the monitor and stand falling down, potentially causing damage or bodily injury.
- This unit does not come with anchor bolts for securing it to walls, etc. Be sure you have materials on hand as appropriate for the mounting location.
- The monitor should be mounted to a wall that can adequately hold the total weight of the monitor and stand over a long period of time and which can adequately withstand earthquakes, conceivable vibrations, and other external forces.
- **Mounting On Wooden Walls**
The weight of the unit should be borne by the wall posts or studs, and these should be reinforced if insufficiently strong. Do not install the Wall Mounting Unit on walls made of plasterboard or thin plywood. Use the commercially sold screws best suited for the wall structure and material.
- **Mounting On Concrete Walls**
Use commercially sold wall anchors capable of supporting the weight of the monitor.
- Do not install the Wall Mounting Unit near the blower or air inlet of an air conditioner.
- Do not install the Wall Mounting Unit in a location subject to frequent vibration, impact or other external forces.
- Do not install the unit in a location where people may hang on it or lean against it.
- Do not block the ventilation holes.
- Do not install the monitor on a non-vertical wall.

! Caution

- Consult authorized service personnel for electrical work. Using power cords damaged during installation (i.e., exposed or severed wiring) may result in fire or electric shock.
- Conduct the work with adequate working space. Damage or bodily injury may result from working under unsuitable conditions.
- Avoid mounting this unit in areas where there is electrical wiring or water pipes, as fire or electric shock may result.

- 1 Lay the monitor on a cloth with the LCD panel facing down to prevent the LCD panel from being damaged. Loosen the stand screws on the stand support and remove the bottom plate.

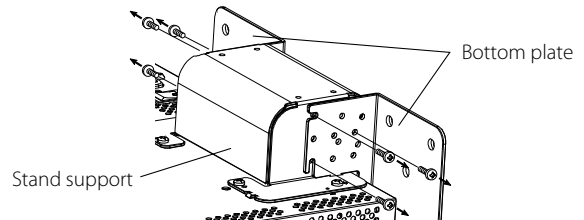

- 2 Temporarily set the stand screws in screw holes "2" and "4" on the right and left sides of the stand support.
 - Tighten the temporarily set stand screws so that they protrude from the screw holes by about 4 mm.

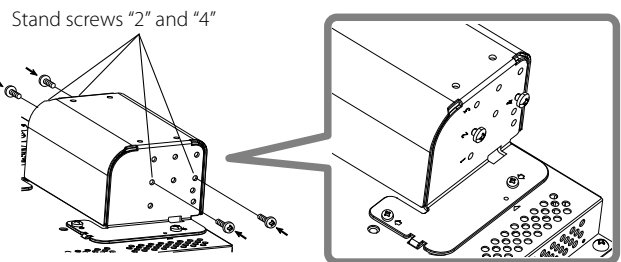

- 3 Tighten commercially available screws in the 6 holes shown in the figure below to install the monitor on the wall.

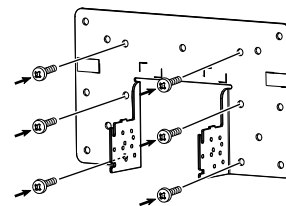

- 4 Hook the temporarily set screws on the stand support in right and left recesses "A" and "B" on the bottom plate, tighten the two stand screws in right and left screw holes "D" and finally retighten the temporarily set screws to lock the stand support and bottom plate.

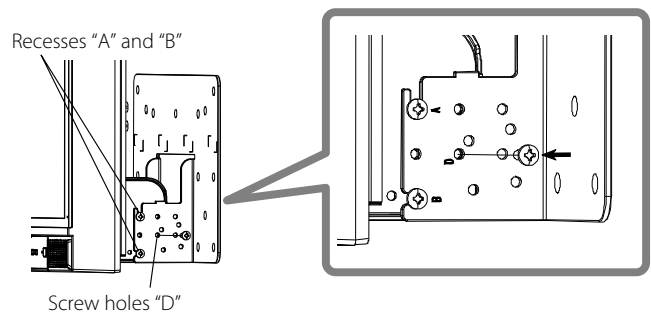

Index of Parts and Functions

Rear panel

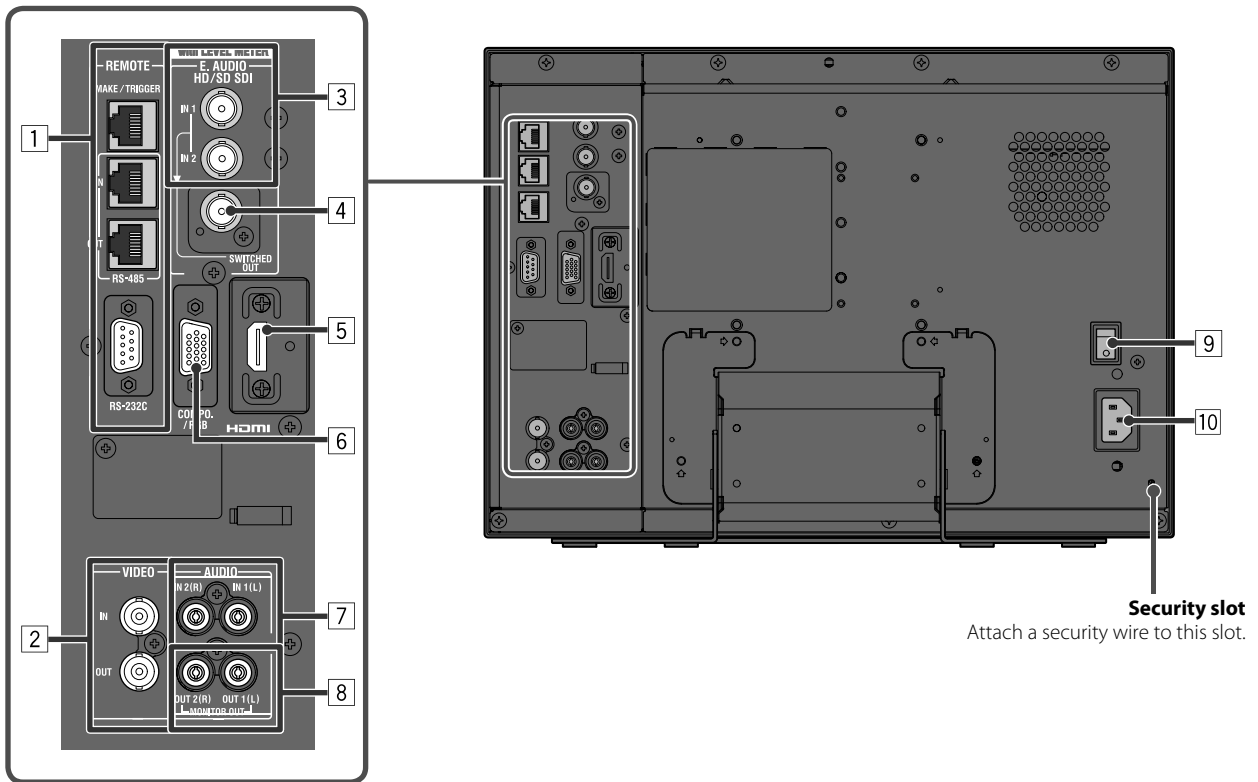

Security slot
Attach a security wire to this slot.

1 REMOTE terminal

Terminal for controlling the monitor by an external control (☞ “External Control” on page 40).

2 VIDEO terminals (BNC)

Input (IN) and output (OUT) terminals for the composite signals.

3 E. AUDIO HD/SD SDI (IN 1, IN 2) terminals (BNC)

Input terminals for the HD/SD SDI signals.

- The terminals accept also EMBEDDED AUDIO signals including up to 16 audio channels with a sampling frequency of 48 kHz.

4 E. AUDIO HD/SD SDI (SWITCHED OUT) terminal (BNC)

Output terminal for the HD/SD SDI signals.

- The SDI signals of the current input (SDI 1 or SDI 2) are re-clocked, then emitted.
- When an input other than SDI 1 and SDI 2 is selected, the SDI signal of the input selected last time is emitted from this terminal.
- The signals are emitted from this terminal only when the monitor is on or in “Power Save” (power save) mode (☞ “No Sync Action” on page 35).

5 HDMI terminal

Input terminal compatible with HDCP for the HDMI signal. (☞ page 48)

6 COMPO./RGB terminal (mini D-sub 15pin)

Input terminal for the analog component signal or analog RGB signal. (☞ page 48)

- Set “Component/RGB Select” (☞ page 33) appropriately for input signals.

7 AUDIO (IN) terminals (pin jack)

Input terminals for the analog audio signals.

- Use this terminal for the analog audio connection of the SDI. When inputting audio into this terminal, set “SDI-1 Select” or “SDI-2 Select” of the menu to “1ch+2ch”, “1ch” or “2ch” (☞ page 34).
- When you use HDMI input for the picture and analog sound for the audio signal, input analog sound into this terminal, and set “HDMI Select” of the menu to “1ch+2ch”, “1ch” or “2ch” (☞ page 34).

8 AUDIO (MONITOR OUT) terminals (pin jack)

Output terminals for the analog audio signal.

- The terminals emit the audio signals through the AUDIO (IN) terminal or EMBEDDED AUDIO signals through the E. AUDIO HD/SD SDI (IN 1 or IN 2) input terminal.
- The signal is output from this terminal only when the monitor is on or in "Power Save" (power save) mode (see "No Sync Action" on page 35).
- The EMBEDDED AUDIO signal...
 - is decoded into an analog signal, then emitted.
 - is emitted only when "SDI 1" or "SDI 2" is selected, and when EMBEDDED AUDIO signals come in to the E. AUDIO HD/SD SDI (IN 1 or IN 2) terminal.
- Audio signals are only output from the HDMI terminal when the signals are not protected by HDCP.
 - Even when the signals are protected by HDCP, sound is emitted from the speakers.

9 POWER switch

Turns AC power on or off.

- You need to press  button (see 17 on page 28) to use the monitor after turning on the POWER switch.

10 AC IN terminal

AC power input connector.

Connect the provided AC power cord to an AC outlet.

CAUTION

Do not connect the power cord until all other connections are completed.

Note for connections

- Before making any connections, turn off all the equipment.
- Use a cord whose plugs correctly match the terminals on this monitor and the equipment.
- Plugs should be firmly inserted; poor connections could cause noise.
- When unplugging a cord, be sure to grasp its plug and pull it out.
- DO NOT connect the power cord until all connections are complete.
- Refer also to the user manual of each piece of equipment.

Index of Parts and Functions (cont.)

Front panel

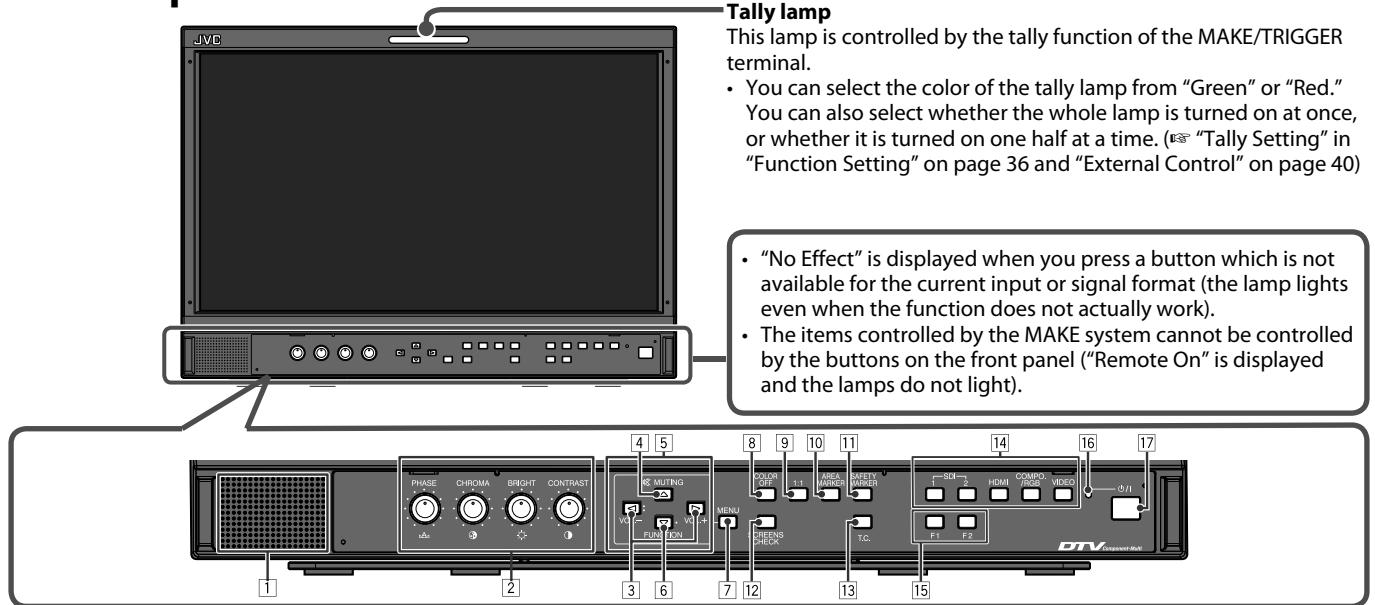

Tally lamp

This lamp is controlled by the tally function of the MAKE/TRIGGER terminal.

- You can select the color of the tally lamp from "Green" or "Red."
- You can also select whether the whole lamp is turned on at once, or whether it is turned on one half at a time. (☞ "Tally Setting" in "Function Setting" on page 36 and "External Control" on page 40)

- "No Effect" is displayed when you press a button which is not available for the current input or signal format (the lamp lights even when the function does not actually work).
- The items controlled by the MAKE system cannot be controlled by the buttons on the front panel ("Remote On" is displayed and the lamps do not light).

1 Speaker (monaural)

The speaker emit the same audio signal emitted from the AUDIO (MONITOR OUT) terminals. (☞ "[8] AUDIO terminals" on page 17)

2 Picture adjustment knob

- PHASE:** Adjusts the picture hue
CHROMA: Adjusts the picture color density
BRIGHT: Adjusts the picture brightness
CONTRAST: Adjusts the picture contrast
- PHASE and CHROMA cannot be adjusted for certain signal formats.
 - When "Component Phase" is set to "Disable" and an NTSC signal is input, PHASE can be adjusted (☞ page 36).

3 VOLUME adjustment button/EMBEDDED AUDIO setting button

Adjusts the volume when no menu screen is displayed. Selects an audio channel when EMBEDDED AUDIO signals are contained in SDI input. (☞ "Volume Adjustment/Audio Channel Selection" on page 29)

4 MUTING button

- Turns off the sound (Muting).
- To cancel the function, press the button again.
 - Muting function is also canceled when volume is adjusted (☞ page 29).

5 </> / Δ / ▽ buttons

When a menu screen is displayed selects or adjusts menu items. (☞ "The operation procedure" on page 30)

6 FUNCTION button

Assign functions to the F1 and F2 buttons when the menu is not displayed. (☞ page 36)

7 MENU button

Activates/deactivates the display of the Main Menu. (☞ "The operation procedure" on page 30)

8 COLOR OFF button/lamp

- Displays only the luminance signal.
- This function does not work for RGB input signals.

9 1:1 button/lamp

- Displays the picture in the original resolution of the input signal.
- The aspect ratio of the picture may change depending on the input signal.

10 AREA MARKER button/lamp

- Displays/hides the area marker.
- Select the style of the area marker in "Marker" of the Main Menu (☞ page 33).
 - This function works only when displaying the picture in 16:9 aspect ratio.
 - This function does not work when "Area Marker" or "R-Area Marker" is set to "Off" in "Marker."

11 SAFETY MARKER button/lamp

- Displays/hides the safety marker.
- Adjust the area of the safety marker in "Marker" of Main Menu (☞ page 33).
 - This function will not work when the picture is displayed in 1:1 aspect ratio and "SD4:3 Size" on the menu is set to "H Full".
 - This function does not work when "Safety Marker" or "R-Safety Marker" is set to "Off" in "Marker."

12 SCREENS CHECK button/lamp

- Displays only the selected element (R, G, or B) of the video signal.
- Each time you press this button, the picture changes in the following order.

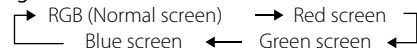

13 T.C. (time code) button/lamp

- Activates/deactivates the display of the time data (time code) contained in the SDI signal. (☞ "On the Information Display" on page 29)
- Select the time code type in "Information" of Set-Up Menu (☞ page 38).

14 INPUT SELECT buttons/lamps

- Selects an input.
- SDI 1:** E. AUDIO HD/SD SDI (IN 1) terminal
SDI 2: E. AUDIO HD/SD SDI (IN 2) terminal
HDMI: HDMI terminal
COMPO./RGB: COMPO./RGB terminal
VIDEO: VIDEO terminal
- The lamp for the selected input lights.

15 F1/F2 buttons/lamps

You can use the functions assigned to this button.

16 Power lamp

- Unlit:** The monitor is completely off (the POWER switch on the rear panel is turned off) or in Low Power Mode (☞ page 39)
- Lights in Green:** The monitor is on
Lights in orange: The monitor is off (on standby)
Flashes in orange: The monitor is in the Power Save (power save) mode (☞ "No Sync Action" on page 35)

17 ⏻ / I button

- Turns on and off (on standby) the monitor.
- The POWER switch is equipped on the rear panel of the monitor (☞ [9] on page 27).

Showing Input Signals

Volume Adjustment/Audio Channel Selection

Volume Adjustment

- When no menu screen is not displayed, press <D> (volume adjustment button).
For SDI input the "Volume/Embedded Audio" screen appears. For any input other than SDI the "Volume" screen appears.
- Press ▾ to move the cursor to "Volume".
(This step is skipped when the "Volume/Embedded Audio" screen is not displayed.)
- Press <D> to adjust the volume.
- Press the MENU button to finish.
(The "Volume" screen disappears automatically if no operations are made for 5 seconds.)

Audio Channel Selection

Select the audio channel output from the Speaker (monaural) and AUDIO (MONITOR OUT) (OUT1(L)/OUT2(R)) terminals when an EMBEDDED AUDIO signal is input during SDI input.

- It is necessary to set the audio channel group in advance. (☞ "Embedded Audio Group" of "Audio Setting" on page 34)
 - Store the setting for each input of SDI 1 and SDI 2.
- When the menu is not displayed, use the <D> buttons
The "Volume/Embedded Audio" screen appears.
 - The "Volume/Embedded Audio" screen disappears automatically if no operations are made for about 30 seconds.
 - Use the △ ▾ buttons to select the left and right channels (L ch/R ch)
 - Use the <D> buttons to select the audio channel
 - Each time you press a button the audio channel changes according to the "Embedded Audio Group" setting. (☞ on page 34)
 - Press the MENU button
 - The "Volume/Embedded Audio" screen disappears.

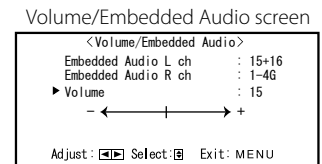
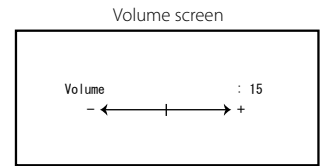

On the Information Display

The monitor displays the information below.

- Make the setting to display/hide each information using the MENU with the exception of ⑤, controlled with T.C. button (☞ ⑬ on page 28).

① Audio level meter

- You can check the conditions of the EMBEDDED AUDIO signals when "Level Meter Display" is set to "Horizontal" or "Vertical."
- Not displayed when "Level Meter Display" is set to "Off." (☞ "Audio Setting" on page 34)

② Signal format

- Displayed when "Status Display" is set to "On." (☞ "Information" on page 38)
- For the contents displayed, see "Available signals" on page 37 and "On the signal format" below.

③ Source name assigned in "Character Setting" (☞ "Information" on page 38)

- Displayed when "Source ID" is set to "On" or "Auto."
- Displayed in large letters when "Status Display" is set to "Off" or "Auto."

④ CRC error indication

- Displayed when "CRC Error" is set to "On." (☞ "Information" on page 38)
- A red square is displayed when an error occurs.

⑤ Time code

- Press T.C. button (☞ ⑬ on page 28).
- When the input signal includes no time code, "TC --:--:--:--" is displayed (☞ ⑬ on page 28).

On the Status Display

If you press the INPUT SELECT button (☞ ⑭ on page 28) currently lit, the status of the input signal and setting of MUTING are displayed for about 3 seconds.

- Make the setting to display/hide the status in "Status Display" of the "Information" (☞ page 38).
- When "Status Display" is set to "Auto" or "On," the status below is also displayed in the following cases:
 - When you change the input
 - When the signal condition of the current input changes
 - When you turn on the monitor
- When "Status Display" is set to "On," the signal format will remain displayed 3 seconds after the status is displayed.

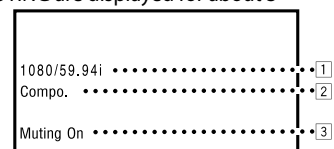

① Signal format

- For the contents displayed, see "Available signals" on page 47 and "On the signal format" below.

On the signal format

The following messages appear depending on the type of input signals and their conditions.

- When a HDMI signal protected with HDCP is input** → "H" (at the end of the indication)
- When no video signal comes in** → "No Sync"
- When a noncompliant video signal comes in** → "Out of range"

② Signal format of HDMI and COMPO./RGB input

③ Setting of "MUTING"

- Only appears when in mute mode. (☞ ④ on page 28).

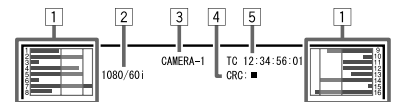

Menu Configuration

First Time Installation

When you turn on the power and the monitor, "First Time Installation" appears. Start setting referring to the menu configuration.

For the setting items, see the pages below.

- "Language" ↔ "Language" on page 38
- "No Sync Action" ↔ "Sync Function" on page 35
- "No Operation Action" ↔ "No Operation Action" on page 35

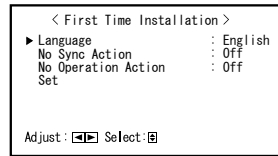

- Once the settings have been adjusted, this screen will not appear again.
- The settings can be changed afterwards in Main Menu and Set-Up Menu.

Setting procedure

- 1 Press Δ / ∇ to move the cursor to the setting item
- 2 Press \triangleleft / \triangleright to select the setting values
 - Each time you press one of these buttons, the setting value changes.
- 3 Move the cursor to "Set"
- 4 Press \triangleright to finish setting
 - When you change the settings, a confirmation message appears. Operate according to directions.

The operation procedure

1 Press the MENU button to display the Main Menu

To display the Main Menu

➔ Press the MENU button.

To display the Set-Up Menu

➔ Press the \triangleleft button while holding the ∇ button.

2 Use the Δ / ∇ buttons to select an item and press the \triangleright button to proceed to the next screen

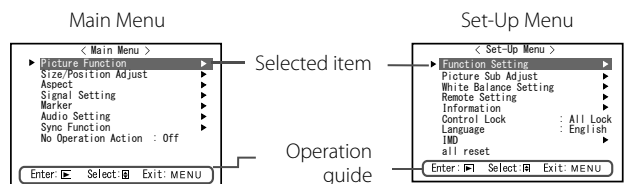

Ex.: When "Picture Function" in the Main Menu is selected

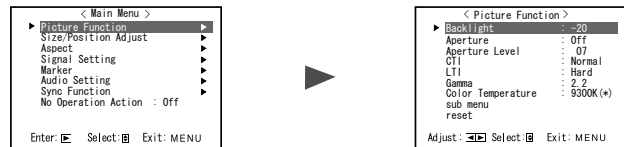

3 Use the Δ / ∇ buttons to select an item and press the \triangleright button to proceed to the next screen

- For some items, pressing the \triangleleft / \triangleright buttons adjusts the setting.

4 Use the Δ / ∇ buttons to select an item and use the \triangleleft / \triangleright buttons to adjust the setting

5 Press the MENU button to finish operations

- Press the MENU button repeatedly until the menu screen disappears.

- The menu screen disappears automatically if no operations are made for about 30 seconds.
- Inoperable menus will be grayed out.
- Some items will not be displayed on the menu depending on the selected input and signal format.

Menu Transition Diagram

Main Menu

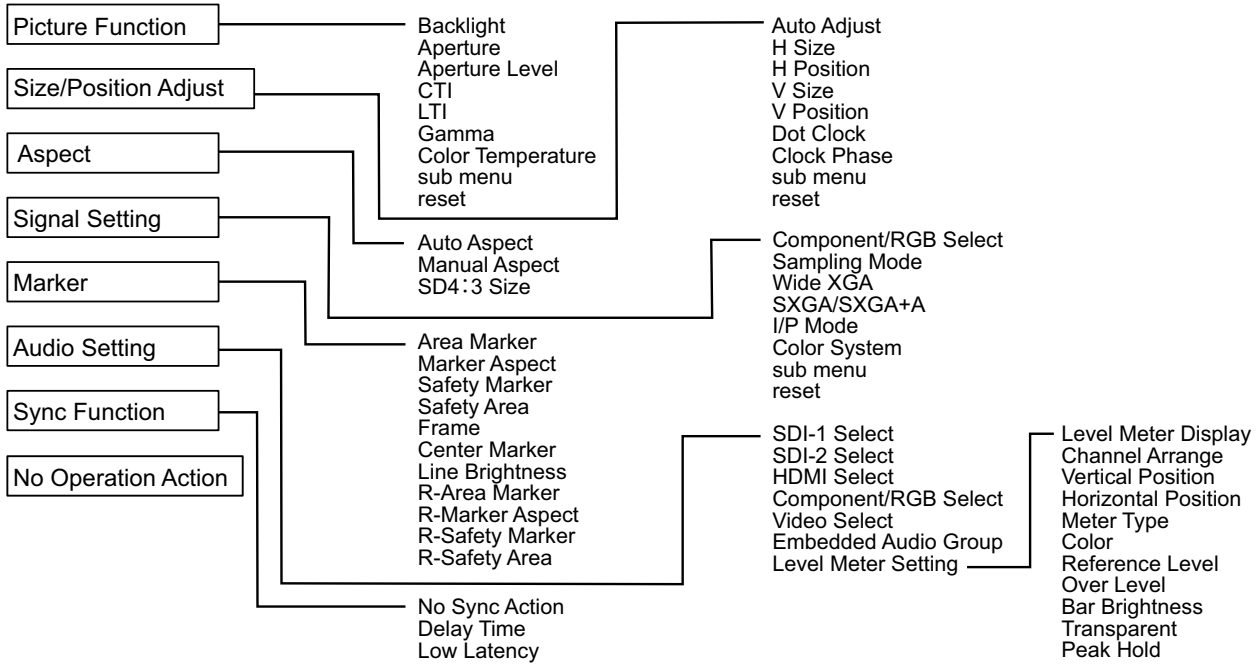

Set-Up Menu

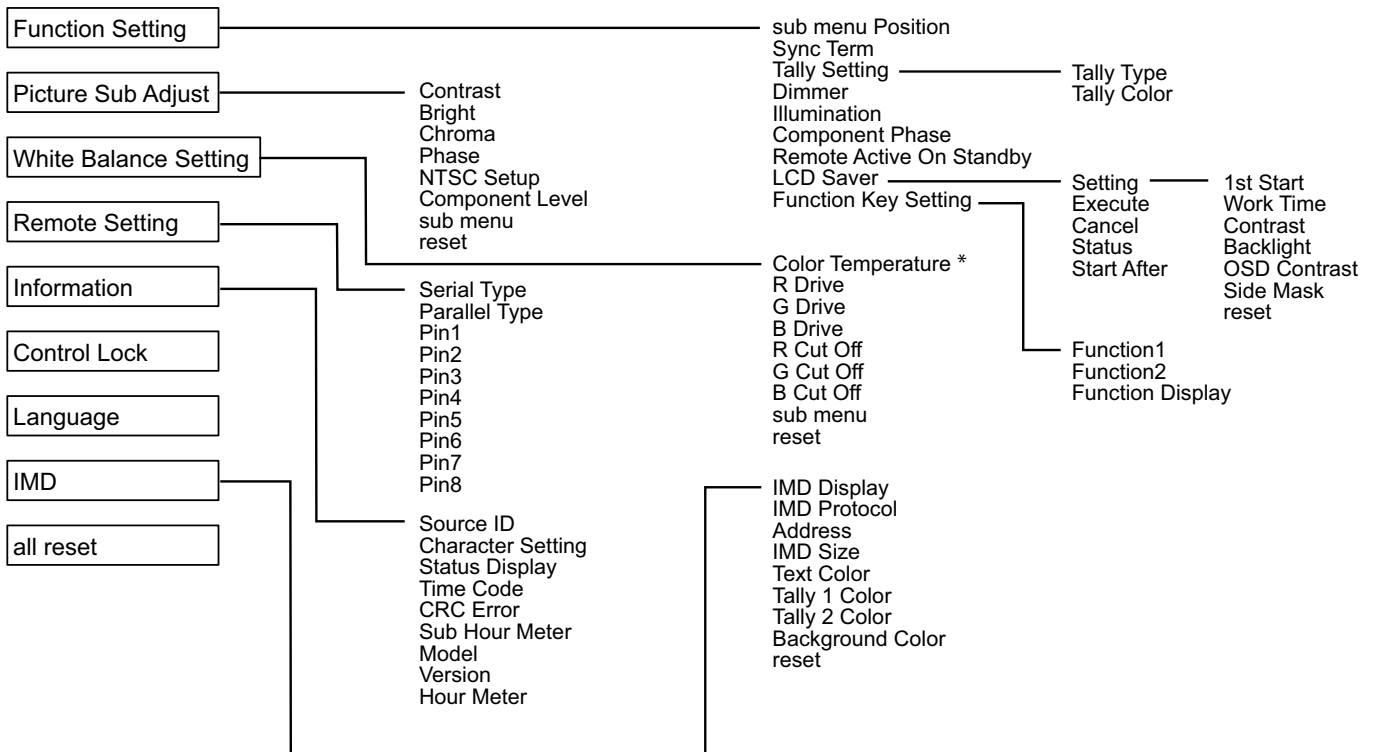

* : "Color Temperature" is only displayed, and cannot be set/changed.

Menu Configuration (cont.)

Main Menu

Picture Function

Setting for the picture quality.

Item	To do	Setting value
Backlight	Adjusts the brightness of the display.	-20 to +20
Aperture* ^{*1}	Activates/deactivates the function at the level set in "Aperture Level".	Off, On
Aperture Level* ^{*1}	Compensate the frequency response of the luminance signal of the video signal.	01 – 10
CTI	Adjust the clearness of the outlines of the chrominance signal.	Off, Normal, Hard
LTI	Adjust the clearness of the outlines of the luminance signal.	Off, Normal, Hard
Gamma	Select the Gamma correction value.	2.2 (equivalent to Y 2.2), 2.35 (equivalent to Y 2.35), 2.45 (equivalent to Y 2.45), 2.6 (equivalent to Y 2.6)
Color Temperature	Select the color temperature.	9300K(*), 6500K(*), User
sub menu	Display the sub menu which enables you to adjust the items in "Picture Function" while viewing the actual picture.	
reset	Restore the default settings for all the items in "Picture Function".	

*1 Memorized for each input.

Size/Position Adjust

Adjusts the size and position of the picture.

Item	To do	Setting value
Auto Adjust	Activate/deactivate the function to adjust the optimized position for each input signal.	
H Size* ^{*1}	Adjust the horizontal picture size.	Setting value varies depending on the signals.
H Position* ^{*1}	Adjust the horizontal picture position.	
V Size* ^{*1}	Adjust the vertical picture size.	
V Position* ^{*1}	Adjust the vertical picture position.	
Dot Clock* ^{*1}	Adjust "Dot Clock" and "Clock Phase" alternately when the displayed picture becomes unstable or streaked.	
Clock Phase* ^{*1}		
sub menu	Display the sub menu which enables you to adjust the items in "Size/Position Adjust" while viewing the actual picture.	
reset	Restore the default settings for all the items in "Size/Position Adjust".	

*1 Memorized for each signal format.

Aspect

Sets the aspect ratio of the screen for displaying videos.

Item	To do	Setting value
Auto Aspect	Select whether to adjust the aspect ratio (horizontal to vertical ratio of the screen) of the SD signal automatically or manually (Manual Aspect).	Off, On
Manual Aspect* ^{*1}	Sets the aspect ratio (horizontal to vertical ratio of the screen) of the SD signal.	16:9, 4:3
SD4:3 Size* ^{*1}	Selects the picture size when the input signal format is 4:3. Normal : Matches the vertical picture size to the number of pixels. H Full : Matches the horizontal picture size to the horizontal size of the screen. At this time, the top and bottom of the picture are overscanned.	Normal, H Full

*1 Not activate when picture is displayed in the 1:1 mode.

Signal Setting

Settings for input signals.

Item	To do	Setting value
Component/RGB Select	Selects the signal type you want to use for COMPO./RGB terminals.	Component, RGB
Sampling Mode	Analog RGB input Standard: When the input signal is VGA60 or XGA60 Wide: When the input signal is WVGA60 or WXGA60 When the input signal is other than the above, the setting value does not affect the displayed image.	Standard, Wide
Wide XGA	Select the analog WIDE XGA signal format.	1280*768, 1360*768
SXGA/SXGA+A	Select the format when the analog SXGA60 signal comes in. SXGA: Select this when the SXGA60 signal comes in. SXGA+A: Select this when the SXGA+60/SXGA+60* signal comes in. When the input signal is other than the above, the setting value does not affect the displayed image.	SXGA, SXGA+A
I/P Mode*1	Selects a proper mode corresponding to the input picture.	Normal, Cinema, Field
Color System	Select the color system. • If the picture is unstable with "Auto," select the color system according to the input signal.	Auto, NTSC, PAL, SECAM, NTSC 4.43, PAL-M, PAL-N, PAL60
sub menu	Display the sub menu which enables you to adjust the items in "Signal Setting" while viewing the actual picture.	
reset	Restore the default settings for all the items in "Signal Setting".	

*1 When "Low Latency" on the menu is set to "On", forcefully perform I/P conversion using "Field" processing.

Marker*1

Settings for marker functions.

Item	To do	Setting value
1/2 Area Marker	Activate/deactivate the area marker and select the style of it. The setting values and features are as follows. Off : Deactivate the marker. Line : Displays the area with an outline. Half : The area outside the specified aspect ratio of the screen is displayed at 50% transparency. Half + Line : The area of the specified aspect ratio of the screen is indicated by an outline, and the area outside of that is displayed at 50% transparency.	Off, Line, Half, Half + Line
Marker Aspect	Select the aspect ratio of the area marker.	4:3, 14:9, 13:9, 2.35:1, 1.85:1, 1.66:1
Safety Marker	Activate/deactivate the safety marker and select the style of it.*2	Off, Line, Half, Half + Line
Safety Area	Adjust the area of the safety marker.	80% – 100%
Frame*3	Displays/Hides the video area.	Off, On
Center Marker*3	Displays/hides the marker indicating the center position of the picture.	Off, On
Line Brightness	Adjust the brightness of the marker.	High, Low
2/2 R-Area Marker	Activate/deactivate the area marker and select the style of it.*2	Off, Line, Half, Half + Line
R-Marker Aspect	Select the aspect ratio of the area marker.	4:3, 14:9, 13:9, 2.35:1, 1.85:1, 1.66:1
R-Safety Marker	Activate/deactivate the safety marker and select the style of it.*2	Off, Line, Half, Half + Line
R-Safety Area	Adjust the area of the safety marker.	80% – 100%

● The area marker or the safety marker is displayed by using AREA MARKER or SAFETY MARKER button, or external control.

● "R" means "REMOTE (External control)". Select either non-"R-" items or "R-" items to activate by using external control. (☞ "External Control" on page 40)

● When a picture is displayed in 4:3 aspect ratio, the safety marker for the 4:3 area is displayed.

● To display the safety marker for the area of a picture displayed in 16:9 aspect ratio, set Area Marker to "Off".

*1 Memorized for each signal format.

*2 The setting values are the same as that of "Area Marker".

*3 In 1:1 mode, this display is grayed out and cannot be operated.

Menu Configuration (cont.)

Audio Setting

Settings for the audio signals and audio level meter signal.

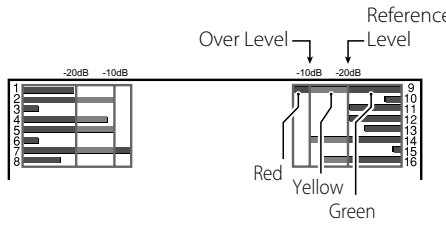
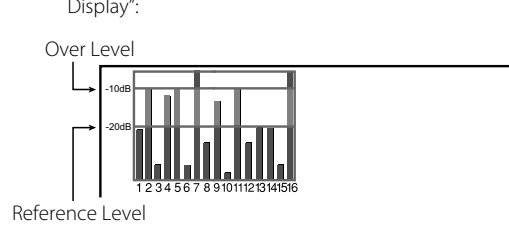
Item	To do	Setting value
SDI-1 Select SDI-2 Select	Select the input through which audio is output. Auto : Output digital audio prior to analog audio. E.Audio : Output audio from the SDI terminal. 1ch+2ch, 1ch, 2ch : Output audio from the AUDIO IN terminal. Off : Does not output audio.	Auto, E.Audio, 1ch+2ch, 1ch, 2ch, Off
HDMI Select	Select the input through which audio is output. Digital : Output audio from the HDMI terminal. 1ch+2ch, 1ch, 2ch : Output audio from the AUDIO IN terminal. Off : Does not output audio.	Digital, 1ch+2ch, 1ch, 2ch, Off
Component/RGB Select Video Select	Select the input through which audio is output. 1ch+2ch, 1ch, 2ch : Output audio from the AUDIO IN terminal. Off : Does not output audio.	1ch+2ch, 1ch, 2ch, Off
Embedded Audio Group* ¹	Select the audio channel group of the EMBEDDED AUDIO signals. The setting values and selectable audio channels of EMBEDDED AUDIO signals are as follows. (G means GROUP) 1G : channel(s) 1/2/3/4/1+2/3+4/1 – 4 (1G) 2G : channel(s) 5/6/7/8/5+6/7+8/5 – 8 (2G) 1-2G : channel(s) 1/2/3/4/5/6/7/8/1+2/3+4/5+6/7+8/1 – 4 (1G)/5 – 8 (2G)/1 – 8 (1G+2G) 3G : channel(s) 9/10/11/12/9+10/11+12/9 – 12 (3G) 4G : channel(s) 13/14/15/16/13+14/15+16/13+14/15+16/ 1-4G : channel(s) 1/2/3/4/5/6/7/8/9/10/11/12/13/14/15/16/1+2/3+4/5+6/7+8/9+10/11+12/13+14/15+16/1-4(1G)/5-8(2G)/9-12(3G)/13-16(4G)/1-8(1G+2G)/9-16(3G+4G)/1-16(1-4G) 3-4G : channel(s) 9/10/11/12/13/14/15/16/9+10/11+12/13+14/15+16/9 – 12 (3G)/13-16(4G)/9-16(3G+4G)	1G, 2G, 1-2G, 3G, 4G, 1-4G, 3-4G
Level Meter Setting* ¹	Specify the audio level meter display for EMBEDDED AUDIO signal. Example of audio level meter display - Connection between the level meter position and channel Ex: When "Horizontal" is selected for "Level Meter Display":  Ex: When "Vertical" is selected for "Level Meter Display": 	
	<ul style="list-style-type: none"> The number of audio channels displayed on the level meter varies depending on the setting value of "Embedded Audio Group". The level meter with no audio signal input is displayed in white for "3Colors", and in gray for "White". Display position When "Horizontal" is selected for "Level Meter Display", the display position will be the top or bottom of the screen. When "Vertical" is selected for "Level Meter Display", the display position will be the lower right, lower left, upper left, or upper right of the screen. When "On" is selected for "Peak Hold", the maximum value is retained a certain period when the signal level becomes maximum. 	
Level Meter Display	Select the status of the level meter (display vertically, horizontally, or not displayed).	Off, Vertical, Horizontal
Channel Arrange	Select how the audio channels are displayed on the level meter.	Line, Divide
Vertical Position	Adjust the vertical level meter position.	1, 2, 3, 4
Horizontal Position	Adjust the horizontal level meter position.	Upper, Lower
Meter Type	Specify the design of the level meter.	Bar, Block
Color	Select the color of the level meter display.	3Colors (colored depending on the level), White (white only)
Reference Level	Select the standard input level indicated on the level meter.	-20dB, -18dB
Over Level	Select the input level's lower limit indicated in red for the "3Colors" display.	-10dB, -8dB, -6dB, -4dB, -2dB
Bar Brightness	Select the brightness of the level meter.	Low, High
Transparent	Adjust the transparency of the level meter display against the image.	Off, Background, All
Peak Hold	Activates/deactivates the peak hold function of the level meter.	Off, On

*¹ Memorized for each input.

Sync Function

Settings for the synchronization with signals.

Item	To do	Setting value
No Sync Action	Select the screen status when no signal is coming in.	Off, Standby, Power Save (power save mode), Gray Back (gray screen)
Delay Time	Select the period until the screen status changes as selected in "No Sync Action" after signals stop coming in.	30s, 5min, 15min
Low Latency	Activates/deactivates the function to shorten the time taken to display the picture (low latency function). <ul style="list-style-type: none">• If the picture is not displayed steadily while "On" is selected, select "Off."• While "On" is selected, the displayed picture may become unstable when an operation using buttons on the front panel or the menu is performed, or when the signal format changes.	Off, On

- When setting "No Sync Action" to "Gray Back," the screen color changes to gray and the power consumption of the backlight is saved by half. Selecting "Power Save" (power save mode) saves more power consumption by turning off the backlight.

No Operation Action Setting values: Off, On

Setting of the function for turning the unit off (standby) automatically when no operations are made for more than 4 hours.

Off: Does not turn off automatically

On: Turns off automatically

- When the function is turned On, a warning message will be displayed about 3 minutes before turning off automatically. When you turn on the unit with the function turned On, a message notifying that the setting is turned on will be displayed for about 30 seconds.

Menu Configuration (cont.)

Set-Up Menu

Function Setting

Settings for the sub menu display, color of the tally lamp, and the intensity of the button lamps.

Item	To do	Setting value
sub menu Position	Select the contents and displaying position of "sub menu." The setting values and features are as follows. Lower1 : Displays the current setting and adjustment bar at the lower part of the screen. Upper1 : Displays the current setting and adjustment bar at the upper part of the screen. Lower2 : Displays the current setting at the lower part of the screen. Upper2 : Displays the current setting at the upper part of the screen. • The adjustment bar is not displayed for some items.	Lower1, Upper1, Lower2, Upper2
Sync Term	Specify the terminal resistant value of the RGB input synchronized signal from the COMPO./RGB terminal. • Normally, select "High". Select "Low" when the display becomes unstable due to the length of a connection cable.	Low, High
Tally Setting	Set the color and mode of the tally lamp using external control.	
Tally Type	Normal : Light up the entire tally. Half : Light up the left and right halves of the tally individually.	Normal, Half
Tally Color	Set the tally color when "Tally Type" is set to "Normal".	Green, Red
Dimmer	Select the intensity of the button lamps.	Normal, Dark
Illumination	Select whether illumination is activated/deactivated.	Off, On
Component Phase	Deactivates the function of PHASE adjustment (Picture adjustment knob and "Picture Sub Adjust" in Set-Up Menu) (※ on page 37) except when an NTSC signal comes in.	Enable, Disable
Remote Active On Standby	Set the conditions for the power switch by external control (serial). On : Can power on by external control after powered OFF. Off : Cannot power on by external control after powered OFF.	Off, On
LCD Saver	Configure the setting for reducing damage to the LCD panel for long-time use. (※ on page 39)	
Setting		
1st Start	Set the standby time.	00h-24h
Work Time	Set the time for performing the function.	01h-06h
Contrast	Set the contrast reduction.	Save, Normal
Backlight	Reduce the backlight brightness.	Save, Normal
OSD Contrast	Set the contrast reduction of the OSD display.	Save, Normal
Side Mask	Select whether to use the side panel. * The Side Mask function works no matter whether the LCD Saver is active or stopped.	Off, On
reset	Restore the default settings for all the items in "LCD Saver".	
Execute	Execute the LCD Saver function.	
Cancel	Stop the LCD Saver function. ("Cancel" will be grayed out during the function stop.)	
Status	Display the LCD Saver status.	Off, Ready
Start After	Stop the LCD Saver function.	**h **min
Function Key Setting	Specify the function assigned to the F1/F2 button.	
Function1	Specify the function assigned to the F1 button.	See pages 31 to 38 for details of the functions assigned to Function 1 and Function 2.
Function2	Specify the function assigned to the F2 button.	
Function Display	Select whether to display the status of the assigned function when you press the F1/F2 button. Off : No status display. Perform the registration function. Mode-1 : Display the status. Perform the registration function. Mode-2 : Display the status. Do not perform the registration function. Perform the registration function when the status is displayed and the button is pressed again.	Off, Mode-1, Mode-2

- You can also display "Function Key Setting" Menu by pressing the ▽ button when the menu is not displayed.
- Each time you press the F1/F2 button, the setting value for the assigned function changes in order.

Ex: When "Color Temperature" is assigned

→ 9300K(*) → 6500K(*) → User

Each time you press the button, three setting values alternate.

Picture Sub Adjust

Configure the standard level of image adjustment.

Item	To do	Setting value
Contrast *1	Adjust the standard level for the contrast adjusted with the CONTRAST knob on the front panel.	-20 to +20
Bright *1	Adjust the standard level for the brightness adjusted with the BRIGHT knob on the front panel.	-20 to +20
Chroma *1	Adjust the standard level for the chroma adjusted with the CHROMA knob on the front panel.	-20 to +20
Phase *1,*2	Adjust the standard level for the phase adjusted with the PHASE knob on the front panel.	-20 to +20
NTSC Setup	Select the set-up level of the input NTSC signal.	00 (compliant with 0 % set-up signal), 7.5 (compliant with 7.5 % set-up signal)
Component Level	Select the level of the analog component signal (480i and 576i only).	B75 (compliant with BetacamVTR 7.5 % set-up signal), B00 (compliant with BetacamVTR 0 % set-up signal), SMPTE (compliant with M2VTR signals)
sub menu	Display the sub menu which enables you to adjust the items in "Picture Sub Adjust" while viewing the actual picture.	
reset	Restore the default settings for all the items in "Picture Sub Adjust".	

*1 Memorized for each input.

*2 When "Component Phase" (E33 page 36) is set to "Disable," "Phase" cannot be adjusted if no NTSC signal is input.

White Balance Setting

Display the color temperature, and adjusts the drive level and cutoff point of each color (R/G/B).

Item	To do	Setting value
Color Temperature	Select the color temperature. (Cannot be set/changed)	9300K(*), 6500K(*), User
R Drive *1	Adjust the drive level of each color (red, green, and blue).	Min - 000 - Max
G Drive	● The maximum (Max) and minimum (Min) values vary depending on the input signal or other settings.	(in 1024 grades)
B Drive		
R Cut Off *1	Adjust the cutoff point of each color (red, green, and blue).	Min - 000 - Max
G Cut Off	● The maximum (Max) and minimum (Min) values vary depending on the input signal or other settings.	(in 1024 grades)
B Cut Off		
sub menu	Display the sub menu which enables you to adjust the items in "White Balance Setting" while viewing the actual picture.	
reset	Restore the default settings for all the items in "White Balance Setting".	

*1 Memorized for each color temperature.

Remote Setting

Settings for the external control.

Item	To do	Setting value
Serial Type	Select a terminal for external control in serial mode.	RS232C, RS485
Parallel Type	Select a control method of the MAKE/TRIGGER terminal.	Make, Trigger, Set
Pin1		
Pin2	Assign the control functions to the pins of the MAKE/TRIGGER terminal.	E33 "Display" in "Functions controlled by the Make/Trigger system" on page 41
Pin3	• Assign a function to each pin terminal by selecting "Set" in "Parallel Type" mentioned above.	
Pin4		
Pin5		
Pin6	The functions are assigned for "Pin6" - "Pin8" and you cannot change the assignment of these functions.	Tally
Pin7		Enable
Pin8		GND

Menu Configuration (cont.)

Information

Settings for the information display of the monitor.

Item	To do	Setting value
Source ID	Select whether the name assigned in "Character Setting" is displayed on the screen (☞ "On the Information Display" on page 29). • When "Auto" is selected, the display color synchronizes with the color of the tally lamp while the tally lamp is lit.	Off, On, Auto
Character Setting	Assign a name to each video source as you like (10 characters at maximum) (☞ Page 39). You can also enter a name using the RS-232C system.	
Status Display	Display/Hide the status of the current input and the setting of MUTING. (☞ "On the Status Display" on page 29)	Auto, Off, On
Time Code	Select the type of the TIME CODE display.	VITC*1, LTC*1, D-VITC
CRC Error	Display/Hide the CRC error when the HD SDI signal is input. (☞ "On the Information Display" on page 29)	Off, On
Sub Hour Meter	Display the hours of use (unit: hour). The usage time can be reset to 0.	
Model	Display the model name of the monitor.	
Version	Display the version of the monitor.	
Hour Meter*2	Display the total hours of use (unit: hour). This item is used for maintenance of the monitor. You cannot reset this item.	

*1 Ancillary time code

*2 "Hour Meter" and settings specified using the front knob are not reset.

Control Lock*3 Setting values: Off, Volume Lock, All Lock

Settings for disabling the buttons on the front panel.

- *3
- The following operations are not available when "Volume Lock" is selected.
 - Picture adjustment knob
 - The "All Lock" function disables to control the buttons on the front panel. But following operations are available.
 - Turning on/off (on standby) the monitor
 - Displaying the Set-Up Menu by pressing ◀ button while holding ▽ button and turning "Control Lock" to "Off"
 - Operating the monitor by an external control
- If you try other operations, "Control Lock on!" appears on the screen.

Language Setting values: English, Deutsch, Français, Español, Italiano, Русский

Select the displayed language for the menu, etc.

IMD

Settings for IMD (In-monitor Display). (☞ Page 39)

Item	To do	Setting value
IMD Display	Display setting On: Displayed, Off: Not displayed	On, Off
IMD Protocol	Serial communication protocol setting Off: Supports JVC protocol, TSL V4.0: Supports TSL UMD Protocol V4.0	Off, TSL V4.0
Address	Address setting 000 to 126: Set a particular address	000 to 126
IMD Size	Text size setting Small: Small size, Large: Large size	Small, Large
Text Color	Text color setting Command: Same color as that set for communication (Command) Red, Green, Amber, Blue, Cyan, Magenta, White: Color settings	Command, Red, Green, Amber, Blue, Cyan, Magenta, White
Tally 1 Color	Tally 1 color setting Command: Same color as that set for communication (Command) Red, Green, Amber, Blue, Cyan, Magenta, White: Color settings	Command, Red, Green, Amber, Blue, Cyan, Magenta, White
Tally 2 Color	Tally 2 color setting Command: Same color as that set for communication (Command) Red, Green, Amber, Blue, Cyan, Magenta, White: Color settings	Command, Red, Green, Amber, Blue, Cyan, Magenta, White
Background Color	Display background color setting Black: Set the background of the IMD display to black Translucent: The picture on the monitor shows through the IMD display. Transparent: Set the background of the IMD display transparent.	Black, Translucent, Transparent
reset	Return the "IMD" settings to their default values	

all reset

Restores all the settings and adjustments of the monitor to the default.

● **Setting of “Character Setting”**

- 1 Change the input to one that you want to assign a video source name for.
- 2 Select “Character Setting”.
- 3 Press Δ / ∇ buttons to select the first character.
 - Each time you press Δ button, the character changes as follows.
Press ∇ button to reverse the order.
- 4 Press \triangleright button to move the arrow to the next space.
 - The characters entered before moving the arrow are memorized.
- 5 Repeat steps 3 and 4 (10 characters at maximum).
- 6 Press MENU button to store the name.

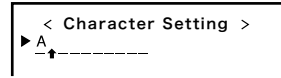
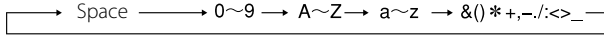
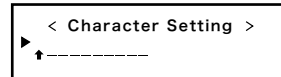

● **How to use the LCD Saver**

1. Set reduced function to perform.
2. Set both time for starting the function and time for letting it work.
3. Activate the STANDBY MODE by Execute.

■ **Aborting the ongoing LCD Saver**

Operating this apparatus may lead to aborting the OPERATION MODE.

■ **Stopping the operation**

Executing “Cancel”. Turn off the power.

- Once operating the function, unless turned off the power or executed “Cancel”, reduced function is automatically performed every 24 hours.

■ **Example of setting up “1st Start” and “Work Time”**

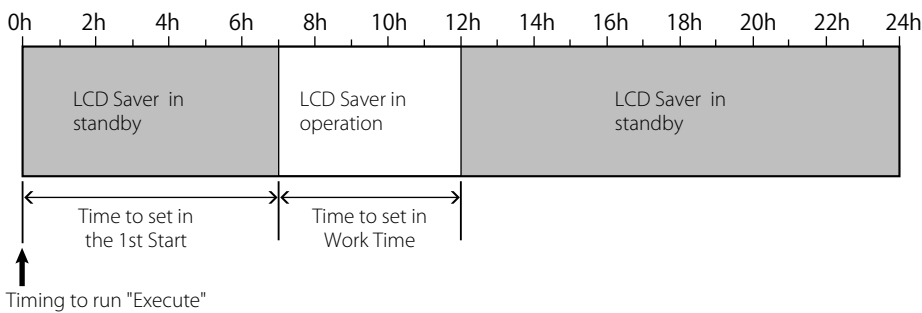

● **IMD (In-monitor Display)**

This unit supports “TSL UMD Protocol – V4.0” from Television Systems Ltd.
 16 character text display and one tally on each side can be controlled.
 The color of both the text and the tally can be set.
 Using the address setting, up to 127 units can be controlled individually.
 To use, set the external control terminals of this unit to serial format.
 For details of control commands, refer to the homepage of Television Systems Ltd.

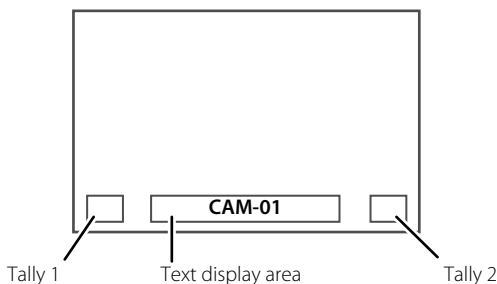

* Example of lower screen IMD display

● **Low Power Mode**

Puts the unit into Low Power Mode 30 seconds after the monitor is switched off (standby) to further reduce power consumption.

- Low Power Mode will not activate when “Remote Active On Standby” on the Set-up Menu is set to “On”.
- The power lamp will be turned off during Low Power Mode.

External Control

About the external control

This monitor has three external control terminals.

- **Make/Trigger terminal** (RJ-45): The following external control systems are available.
 - (1) **Make (make contact) system:**
Controls the monitor by short-circuiting the corresponding pin terminal to the GND pin terminal, or disconnecting (opening) it.
 - (2) **Trigger (trigger) system:**
Controls the monitor by sending the pulse signal instantaneously to the corresponding pin terminal.
 - ☞ "Using the Make/Trigger system" on the right
 - **RS-485 terminals** (RJ-45): Controls the monitor with the RS-485 system (☞ "Using the serial communication" on page 41).
 - **RS-232C terminal** (D-sub 9-pin): Controls the monitor with the RS-232C system (☞ "Using the serial communication" on page 41).
- Set the following items of "Remote Setting" in Set-Up Menu according to the external control terminal and control system (☞ "Serial Type," "Parallel Type" on page 37).

Control terminal	Control system	The settings of this unit	
		"Serial Type" setting	"Parallel Type" setting
Make/Trigger terminal	Parallel Type	Make	—
		Trigger	Make
RS-485 terminal	Serial communication	RS-485	RS485*1
		RS-232C	—
RS-232C terminal			RS232C*1

- *1 For a monitor connected to a personal computer etc, select the terminal the equipment is actually connected to. For other monitors, select "RS485."
- "Make" takes precedence over other controls.
- You can use external control even when "Control Lock" is set to "Volume Lock" or "All Lock" (☞ page 38).
 - When the monitor is off (on standby), external control is not available. But certain external controls (starting/terminating communication, turning on the monitor) are available through the serial communication (☞ page 42).

<Make/Trigger system>

You can control the monitor by a personal computer or dedicated controller*2.

- "Using the Make/Trigger system" on the right.
- *2 The controller is not commercially available. Consult your dealer if you need it.

<Serial communication>

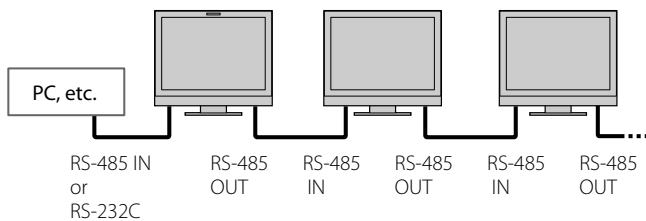

- For the details, see page 41.

Using the Make/Trigger system

The Make/Trigger terminal is configured as follows. You can assign a function to each pin terminal in "Remote Setting" (☞ "Pin1, Pin2, Pin3, Pin4, Pin5" in "Parallel Type" on page 37).

- You cannot change the functions assigned to the pin terminals from 6th to 8th.

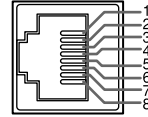

This is a female terminal.

Pin No.	Pin name
1	Pin1
2	Pin2
3	Pin3
4	Pin4
5	Pin5
6	Tally*1
7	Enable*2
8	GND

- *1 The 6th pin terminal controls turning on or off the tally lamp (available to control even when the 7th pin terminal is invalid).
- *2 The 7th pin terminal makes the external control valid/invalid. Keep the 7th pin short-circuited to the 8th pin to make the external control valid.

To assign the functions to the pin terminals

For the operation procedure, see page 30.

- 1 Select "Remote Setting" on the Set-Up Menu.
- 2 Set "Parallel Type" to "Set."
- 3 Select a pin name ("Pin1" – "Pin5") for which you want to assign a function, then select the function you want to assign.
For the selectable functions, see the table on page 41.

Operation of the external control

- 1 Set "Parallel Type" of "Remote Setting" to "Make" or "Trigger" in the Set-Up Menu.
- 2 Keep the 7th pin terminal (Enable) short-circuited to the 8th pin terminal (GND) so that the monitor can be controlled by the external control.
- 3 When the "Make" system is selected: Operate each function by short-circuiting the corresponding pin terminal to the 8th pin terminal (GND) or opening it.
When the "Trigger" system is selected: Operate each function by pulse control, that is short-circuiting the corresponding pin terminal to the 8th pin terminal (GND) for about 1 second and opening it.

- When changing the input with Make system, activate the pin you want after deactivating the currently used pin.
- When selecting the "Trigger" system, you can operate only one function at a time. Operate the functions one by one.

<Functions controlled by the Make/Trigger system>

Display	Functions to be controlled	Opening	Short-circuiting
---	No function.	---	---
Tally Color	Tally lamp color selection.*1	Green	Red
Tally Type	Tally lamp lighting method selection.	Whole	One half at a time
Tally-L(R)	Light the left half of the tally lamp in red.*2	On	Off
Tally-R(G)	Light the right half of the tally lamp in green.*2	On	Off
SDI-1	Changes the input to "SDI 1."	Invalid	Valid
SDI-2	Changes the input to "SDI 2."	Invalid	Valid
HDMI	Changes the input to "HDMI."	Invalid	Valid
Component/RGB	Changes the input to "COMPO./RGB."	Invalid	Valid
Video	Changes the input to "VIDEO."	Invalid	Valid
Area Marker	The area marker indication.	Off	On
Safety Marker	The safety marker indication.	Off	On
Center Marker	The center marker indication.	Off	On
Frame	Indication of the area of the specified aspect ratio.	Off	On
Marker Select	Selects the items of "Marker".*3	Non-"R-" items	"R-" items
Manual Aspect	Changes the aspect ratio.	4:3	16:9
1:1	Displays in 1:1 mode.	Off	On
Status	Status display.*4	☞ "On the Status Display" on page 29	
Level Meter	Audio level meter display.	*5	
Time Code	Time code display.	Off	On
Source ID	☞ "Source ID" in "Information" on page 38.	*6	
Color Off	Color off.	Color	Monochrome
Screens Check	Screens check.	*7	
I/P Mode	Change a mode according to a input picture.	*8	
Muting	Muting on/off.	Off	On
Dimmer	Change the intensity of the button lamps.	Normal	Dark

- *1 Can be controlled when "Tally Type" ("Set-Up Menu" → "Function Setting" → "Tally Setting") is set to "Normal".
 - *2 Can be controlled when "Tally Type" ("Set-Up Menu" → "Function Setting" → "Tally Setting") is set to "Half".
 - *3 Selects which functions in "Marker" are activated, non-"R-" items or "R-" items (☞ "Marker" on page 33).
 - *4 Displays the information shown when INPUT SELECT button of the current input is pressed (☞ "On the Status Display" on page 29). While controlling with the Make system, the information is displayed only at the moment of short-circuiting.
 - *5 While controlling with the Make system, the level meter is switched between displayed (short-circuiting) and hidden (opening). When "Level Meter Display" is set to "Off," the level meter is not displayed ("No Effect" appears).
While controlling with the Trigger system, the pattern of the audio channel display is switched.
 - *6 While controlling with the Make system, the available set-up options will be the setting value currently selected in "Source ID" ("On" or "Auto" [short-circuiting]) and "Off" (opening). While controlling with the Trigger system, uses the same set-up option as those in the Set-Up Menu (☞ "Source ID" in "Information" on page 38).
 - *7 While controlling with the Make system, the screen is switched between normal screen (opening) and blue screen (short-circuiting). While controlling with the Trigger system, the screen changes in the same way as when pressing SCREENS CHECK button (☞ 12 on page 28).
 - *8 Must be controlled with the Trigger system. The mode changes in the order of "Normal" → "Cinema" → "Field." (This function cannot be controlled with the Make system.)
- You cannot assign the same function to different pin terminals.
 - The Trigger system switches each function by short-circuiting the pin terminal for about 1 second and opening it.

Using the serial communication

You can control the monitor from a personal computer etc. via the RS-485 or RS-232C terminal.

* Consult your dealer for the details of the external control specification.

<Communication specifications>

Input terminal	Cable	Terminal specification	Communication specifications
RS-485	A straight LAN cable	☞ See below	Baud Rate: 4800 bps Data Bits: 8 bits Parity: No parity Stop Bits: 1 bit Flow Control: No control Communication Code: ASCII Code
RS-232C	A straight cable with a D-sub 9-pin connector (male for the monitor, female for the personal computer etc.)		

<Specifications of the RS-485 terminal>

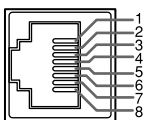

This is a female terminal.

Pin No.	IN terminal signal	OUT terminal signal
1	TXD +	TXD +
2	TXD -	TXD -
3	RXD +	RXD +
4	NC	NC
5	NC	NC
6	RXD -	RXD -
7	NC	NC
8	GND	GND

<Specifications of the RS-232C terminal>

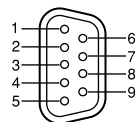

This is a female terminal.

Pin No.	Signal
1	NC
2	RXD
3	TXD
4	NC
5	GND
6	NC
7	RTS
8	CTS
9	NC

- The 7th terminal and the 8th terminal are connected.

External Control (cont.)

<Command outline>

All commands consist of the following segments.

Header	Monitor ID	Function	Data	Cr (0Dh)
--------	------------	----------	------	----------

On Header

"!" : Operation commands from the personal computer, etc. (☞ <Basic command list> below table).

"?" : Reference commands from the personal computer, etc.

"@" : Status returns from the monitor

To start communication, send the connection command from the personal computer etc.

To terminate the communication, send the termination command from the personal computer etc.

Example of communication procedures

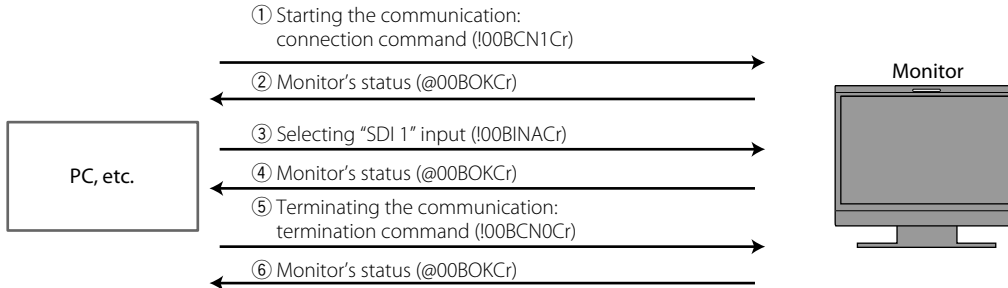

<Basic command list>

No.	Commands	Functions	Data
1	! * **1 B C N 1 Cr	Starts communication (connection)	No data
2	! * **1 B C N 0 Cr	Terminates communication (termination)	No data
3	! * **1 B I D S E T x x*2 Cr	Assigns the control ID	01 – 99
4	! * **1 B I D R E T Cr	Initializes the control ID	No data
5	! * **1 B I D D S P x x*2 Cr	Displays/hides the ID	00: Hide, 01: Display
6	! * **1 B M E N U Cr	Displays the Main Menu/Quits the menu operation	No data
7	! * **1 B U P Cr	Moves the cursor upward (△)	No data
8	! * **1 B D O W N Cr	Moves the cursor downward (▽)	No data
9	! * **1 B A D J R Cr	Makes setting/adjustment (▷)	No data
10	! * **1 B A D J L Cr	Makes setting/adjustment (◁)	No data
11	! * **1 B S E T U P Cr	Displays the Set-Up Menu	No data
12	! * **1 B P W 1 Cr	Turns on the monitor	No data
13	! * **1 B P W 0 Cr	Turns off the monitor (on standby)	No data
14	! * **1 B I N A Cr	Selects "SDI 1" input	No data
15	! * **1 B I N B Cr	Selects "SDI 2" input	No data
16	! * **1 B I N C Cr	Selects "HDMI" input	No data
17	! * **1 B I N D Cr	Selects "COMPO./RGB" input	No data
18	! * **1 B I N E Cr	Selects "VIDEO" input	No data
19	! * **1 B D I S P Cr	Displays the status*3	No data
20	! * **1 B A M U T E x x*2 Cr	Turns muting on/off	00: Off, 01: On
21	! * **1 B A S P x x*2 Cr	Changes the aspect ratio	00: 4:3, 01: 16:9
22	! * **1 B V P L S Cr	Increases the volume	No data
23	! * **1 B V M N S Cr	Reduces the volume	No data
24	! * **1 B V O L x x*2 Cr	Sets the volume	00-30

● "Cr" is 0Dh.

● The commands for starting communication (connection) (No. 1), terminating communication (termination) (No. 2), and turning on the monitor (No. 13) can be used while the monitor is off (on standby).



*1 Enter the monitor's ID for " **." The initial setting of the monitor's ID is "00." When connecting several monitors, "00" is a command for controlling all monitors at once.

*2 Enter the appropriate data to "xx."

*3 Displays the information shown when the INPUT SELECT button currently lit is pressed (☞ "On the Status Display" on page 29).

Troubleshooting

Solutions to common problems related to the monitor are described here. If none of the solutions presented here solve the problem, unplug the monitor and consult an authorized dealer or service center.

Symptom	Probable cause and corrective action	Page
No power supply.	● Press the  /  button.	28
	● Firmly insert the AC power plug.	27
	● Turn on the POWER switch on the rear panel.	27
No picture with the power on.	● Select the correct input using the INPUT SELECT buttons.	28
	● Connect the connecting cable firmly.	26
	● Turn on the power of the connected component and set the output correctly.	—
	● Check whether the input signal format is acceptable on the monitor.	47, 48
No sound.	● Adjust the volume level.	28
	● Deactivate the muting function.	28
	● Connect the connecting cable firmly.	26
	● Turn on the power of the connected component and set the output correctly.	—
"Out of Range" appears.	● Check whether the input signal format is acceptable on the monitor.	47, 48
"No Sync" appears.	● Select the correct input using the INPUT SELECT buttons.	28
	● Connect the connecting cable firmly.	26
	● Turn on the power of the connected component and output video signals. Or, check whether the video output of the component (video output setting of the VCR or graphic board of the computer) is set correctly.	—
Wrong color, no color.	● Adjust each picture adjustment knob on the front panel or adjust the items of "Picture Sub Adjust" in the Set-Up Menu. Or, perform "reset" in "Picture Sub Adjust."	28, 37
	● Check whether the setting of COLOR Off or SCREENS CHECK buttons are appropriate.	28
	● Select the proper color system ("Color System") in "Signal Setting".	33
	● Adjust the items of "White Balance Setting" in the Set-Up Menu. Or, perform "reset" in "White Balance Setting".	37
The picture becomes blurred.	● Adjust the picture contrast or brightness by using the adjustment knobs on the front panel. Or, adjust "Contrast" or "Bright" of "Picture Sub Adjust" in the Set-Up Menu.	28, 37
Wrong picture position, wrong picture size. The picture may sometimes not be able to fill the whole screen depending on the signal. In this case, nothing can be done to solve the problem. Please be aware of this beforehand.	● Check whether the setting of 1:1 is appropriate. ● Check "Manual Aspect" and "SD4:3 Size" settings in Aspect menu. ● Check whether the input signal format is acceptable on the monitor. ● Adjust the picture size (H Size/V Size) or position (H Position/V Position) of "Size/Position Adjust" menu.	28 32 47, 48 32
Buttons on the monitor do not work.	● Set "Control Lock" in the Set-Up Menu to "Off." ● You cannot use the buttons for the items controlled by the Make system. Disable the external control.	28 37, 40

● The following are not malfunctions.

- When a still image is displayed for a long time, it may remain indistinctly on the screen after the picture has changed. Though the remaining picture will disappear after a while, there may be a case that it remains for a long period depending on the length of time the still image was displayed for. This is due to the characteristics of the LCD display and is not a malfunction.
- Red spots, blue spots and green spots on the panel surface are a normal characteristic of LCD panels, and not a problem. The LCD panel is built with very high precision technology; however, be aware that a few pixels may be missing or constantly lit.
- The following symptoms are problems only when pictures or sounds are not played back normally.
 - A slight electric shock occurs when you touch the LCD panel.
 - The top and/or rear panel of the monitor becomes hot.
 - The monitor emits a cracking noise.
 - The monitor emits a mechanical noise.

Troubleshooting (cont.)

Self-check program

This monitor has a self-check function, which allows it to detect malfunctions and alert you. This makes troubleshooting easier. Whenever a problem occurs, one or some of the INPUT SELECT (COMPO./RGB, VIDEO) lamps will flash. If this happens, follow the steps below and contact your dealer to resolve the problem.

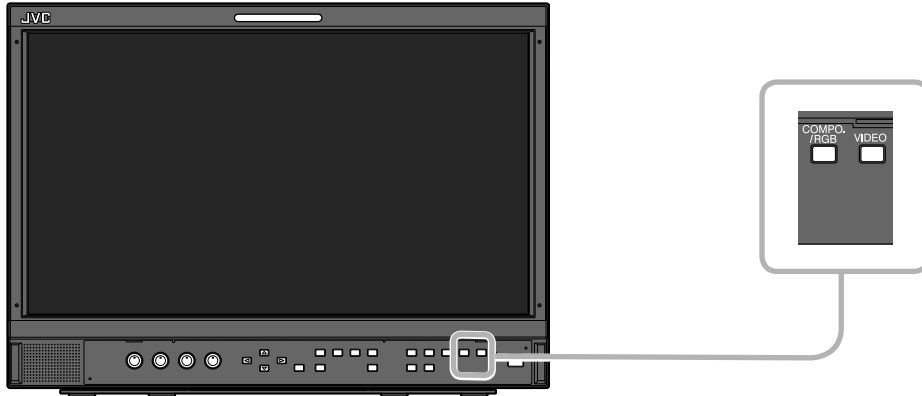

When the screen goes blank, and one or some of the INPUT SELECT (COMPO./RGB, VIDEO) lamps on the front control panel start flashing...

- 1** Check which lamps are flashing.
 - 2** Press  / I button to turn off (on standby) the monitor.
 - 3** Turn off the POWER switch on the rear panel.
 - 4** Disconnect the AC power cord from the AC outlet.
 - 5** Contact your dealer with the information about which lamps were flashing.
- If you turn on the monitor soon after turning it off (or after a short-term power failure), the INPUT SELECT lamps may flash and no image may be displayed.
When this happens, turn off power and wait at least 10 seconds before turning on the monitor again.
If the INPUT SELECT lamps do not flash, you can use the monitor as normal.
 - The self-check function does not work when the setup menu "Remote Active On Standby" is set to "Off" and you turn off the monitor (put the monitor in standby).

Specifications

General

Model name	DT-E15L4	
Type	Multi format LCD monitor	
Screen size	Type 15 wide format	
Aspect ratio	16:9	
Horizontal/vertical frequency (computer signal)	H: 31.469 kHz – 75.000 kHz V: 49.990 Hz – 75.062 Hz * Some signals within this frequency range may not be displayed ("Out of range" is displayed).	
Compliant video signal format	☞ "Available signals" on page 47	
Format	HD SDI: BTA S-004C, SMPTE292M SD SDI: ITU-R BT.656: 525/625 SMPTE259M: 525 EMBEDDED AUDIO: SMPTE299M, SMPTE272M	
Audio output	Internal speaker: 1.0 W	
Operating conditions	Operating temperature: 5°C – 35°C Operating humidity: 20% – 80% (non-condensing) (Slightly variable depending on ambient conditions for installation.)	
Power requirements	AC 120 V / AC 220 – 240 V, 50 Hz/60 Hz	
Rated current	0.6 A (AC 120 V) 0.35 A (AC 220 – 240 V)	
External dimensions (excluding protruding parts)	with the stand	without the stand
	Width: 373 mm	373 mm
	Height: 270.1 mm	265 mm
	Depth: 181 mm	99 mm
Weight	5.9 kg (with the stand)	4.3 kg (without the stand)
Accessories	AC power cord x 2	

LCD panel

Type	15" wide, active matrix TFT
Effective screen size	Width: 344 mm Height: 194 mm Diagonal: 395 mm
Number of pixels displayed	1366 x 768
Number of colors displayed	16.70 million
Viewing angle (TYP.)	170° (Horizontally), 160° (Vertically)
Brightness (TYP.)	300 cd/m ²
Contrast ratio (TYP.)	500:1

Input/output terminals

Video	VIDEO	Input/output of composite signal: 1 line, BNC connector x 2, 1 V (p-p), 75 Ω * The input (IN) and output (OUT) terminals are bridge-connected (auto termination).
	HDMI	HDMI signal input (compatible with HDCP): HDMI connector x 1
	COMPO./RGB (R, G, B, HS, VS or Y, Pb/B-Y, Pr/R-Y)	Analog Component signal input/Analog RGB signal input: 1 Line, mini D-SUB 15pin x1 Y: 1 V(p-p), 75 Ω(with sync) G, B/PB/B-Y, R/PR/R-Y: 0.7 V (p-p), 75 Ω HS, VS: 0.3 V (p-p) to 5 V (p-p) * For HS and VS, change the Low/High terminals manually.
	E. AUDIO HD/SD SDI (IN 1)	Digital signal input (compatible with EMBEDDED AUDIO signals): auto detection, 2 line, BNC connector x 2
	E. AUDIO HD/SD SDI (IN 2)	
	E. AUDIO HD/SD SDI (SWITCHED OUT)	Digital signal output (compatible with EMBEDDED AUDIO signals): 1 line switched out, BNC connector x 1
Audio	AUDIO (IN)	Analog audio signal input: 1 line, RCA connector x 2, 500 mV (rms), high impedance
	AUDIO (MONITOR OUT)	Analog audio signal output: 1 line, RCA connector x 2, 500 mV (rms)
External control	REMOTE (MAKE/TRIGGER)	☞ "Using the Make/Trigger system" on page 40
	REMOTE (RS-485)	☞ "Using the serial communication" on page 41
	REMOTE (RS-232C)	

Specifications (cont.)

Dimensions Unit: mm

DT-E15L4

<Front view>

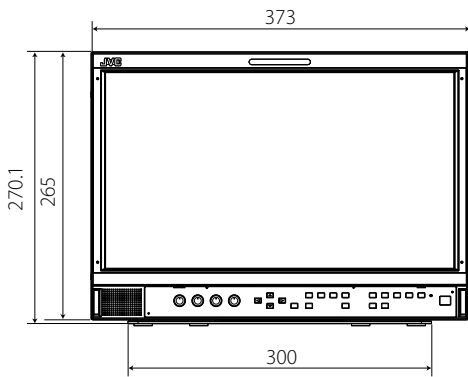

<Side view>

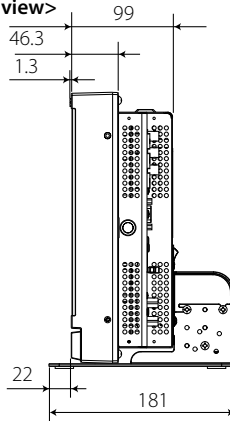

<Rear view>

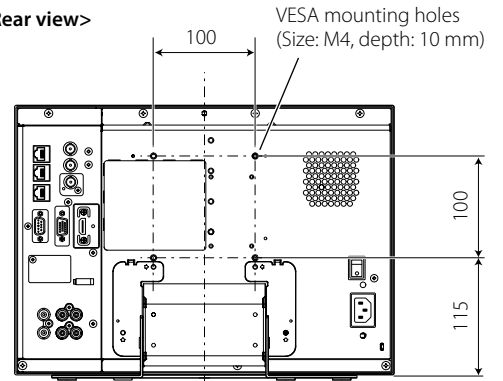

To install the monitor on a shelf

<Top view>

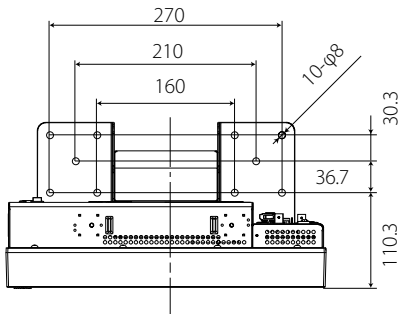

<Side view>

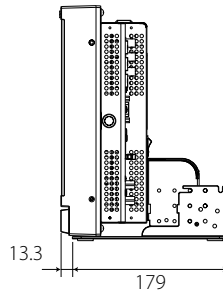

To install the monitor on a wall

<Rear view>

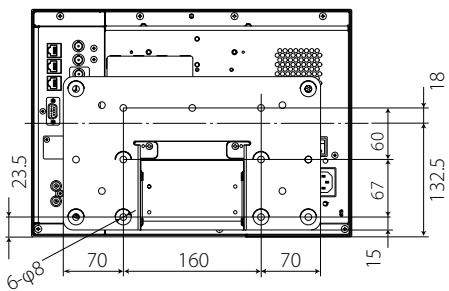

<Side view>

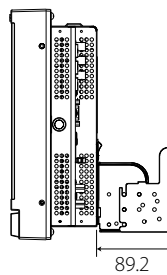

Available signals

The following signals are available for this monitor.

Video signals

No.	Signal name	Signal format shown in the status display (see page 29)*1	Input terminal				
			VIDEO	analog COMPO.	analog RGB	E.AUDIO *2 HD/SD SDI	HDMI
1	NTSC	NTSC	√	—	—	—	—
2	NTSC 4.43	N 4.43	√	—	—	—	—
3	PAL-M	PAL-M	√	—	—	—	—
4	PAL60	PAL60	√	—	—	—	—
5	PAL	PAL	√	—	—	—	—
6	PAL-N	PAL-N	√	—	—	—	—
7	SECAM	SECAM	√	—	—	—	—
8	B/W50	B/W50	√	—	—	—	—
9	B/W60	B/W60	√	—	—	—	—
10	480/60i	480/60i	—	√	—	—	√
11	480/59.94i	480/59.94i	—	√	—	√	√
12	576/50i	576/50i	—	√	—	√	√
13	480/60p	480/60p	—	√	—	—	√
14	480/59.94p	480/60p	—	√	—	—	√
15	576/50p	576/50p	—	√	—	—	√
16	640*480/60p	640*480/60p	—	—	√	—	√
17	640*480/59.94p	640*480/60p	—	—	√	—	√
18	720/60p	720/60p	—	√	—	√	√
19	720/59.94p	720/59.94p	—	√	—	√	√
20	720/50p	720/50p	—	√	—	√	√
21	720/30p	720/30p	—	—	—	√	—
22	720/29.97p	720/29.97p	—	—	—	√	—
23	720/25p	720/25p	—	—	—	√	—
24	720/24p	720/24p	—	—	—	√	—
25	720/23.98p	720/23.98p	—	—	—	√	—
26	1080/60i	1080/60i	—	√	—	√	√
27	1080/59.94i	1080/59.94i	—	√	—	√	√
28	1035/60i	1035/60i	—	—	—	√	√
29	1035/59.94i	1035/59.94i	—	—	—	√	√
30	1080/50i	1080/50i	—	√	—	√	√
31	1080/60p	1080/60p	—	√	√	—	√
32	1080/59.94p	1080/60p	—	√	√	—	√
33	1080/50p	1080/50p	—	√	√	—	√
34	1080/30p	1080/30p	—	—	—	√	√
35	1080/29.97p	1080/29.97p	—	—	—	√	√
36	1080/25p	1080/25p	—	—	—	√	√
37	1080/24p	1080/24p	—	—	—	√	√
38	1080/23.98p	1080/23.98p	—	—	—	√	√
39	1080/30PsF	1080/30psf	—	—	—	√*3	—
40	1080/29.97PsF	1080/29.97psf	—	—	—	√*4	—
41	1080/25PsF	1080/25psf	—	—	—	√*5	—
42	1080/24PsF	1080/24psf	—	—	—	√	—
43	1080/23.98PsF	1080/23.98psf	—	—	—	√	—

√: Acceptable

—: Not acceptable

*1 For signal formats other than E.Audio HD/SD SDI input, **/59.94, **/29.97, and **/23.98 will be displayed as **/60, **/30, and **/24 respectively.

*2 Compatible with EMBEDDED AUDIO signals.

*3 The signal is recognized as 1080/60i, and the status is displayed as "1080/60i."

*4 The signal is recognized as 1080/59.94i, and the status is displayed as "1080/59.94i."

*5 The signal is recognized as 1080/50i, and the status is displayed as "1080/50i."

● HDMI, the HDMI logo, and High-Definition Multimedia Interface are trademarks or registered trademarks of HDMI Licensing LLC in the United States and other countries.

● HDCP stands for High-bandwidth Digital Content Protection, a copy protection technology of high reliability licensed by Digital Content Protection, LLC.

Specifications (cont.)

Computer signals (preset)

Analog RGB input (COMP./RGB terminals) and DVI input (HDMI terminal):

No.	Signal name	Resolution		Frequency		Scan system
		Horizontal	Vertical	Horizontal (kHz)	Vertical (Hz)	
1	VGA60	640	480	31.5	59.9	Non-interlace
2	WVGA60	852	480	31.5	59.9	Non-interlace
3	SVGA60	800	600	37.9	60.3	Non-interlace
4	XGA60	1024	768	48.4	60.0	Non-interlace
5	WXGA (1280)	1280	768	47.8	60.0	Non-interlace
6	WXGA+60 *1	1440	900	55.9	60.0	Non-interlace
7	SXGA60 *1	1280	1024	64.0	60.0	Non-interlace
8	UXGA60 *1	1600	1200	75.0	60.0	Non-interlace
9	WUXGA60 *1	1920	1200	74.0	60.0	Non-interlace
10	1080/60p *1	1920	1080	67.5	60.0	Non-interlace
11	1080/50p *1	1920	1080	56.3	50.0	Non-interlace
12	US TEXT *2, *5	720	400	31.5	70.1	Non-interlace
13	WXGA(1360)	1360	768	47.7	60.0	Non-interlace
14	SXGA+/60A *1, *3	1400	1050	64.0	60.0	Non-interlace
15	SXGA+/60B *1, *4	1400	1050	65.2	60.0	Non-interlace
16	MAC13 *5	640	480	35.0	66.7	Non-interlace
17	MAC16 *5	832	624	49.7	74.5	Non-interlace
18	MAC19 *5	1024	768	60.2	74.9	Non-interlace
19	MAC21 *5	1152	870	68.7	75.1	Non-interlace

*1 No. 6, 7, 8, 9, 10, 11, 14 and No. 15 signals come in, thin lines will become obscured because their signal resolution is higher than the screen resolution.

*2 The signal is recognized as VGA400/70, and the status is displayed as "VGA400/70".

*3 The signal is recognized as SXGA+60, and the status is displayed as "SXGA+60".

4 The signal is recognized as SXGA+60, and the status is displayed as "SXGA+60*".

*5 Only supports analog RGB input.

- Non-preset signals may not be displayed normally even if the frequency is within the acceptable range.
- When a preset signal comes in, the signal format is shown on the status display. When a non-preset signal comes in, "Out Of Range" appears.

Specification of the HDMI terminal

Connect it to the HDMI output terminal of a video device.

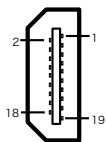

Pin No.	Input signal	Pin No.	Input signal	Pin No.	Input signal
1	T.M.D.S Data 2+	8	T.M.D.S Data 0 shield	15	SCL
2	T.M.D.S Data 2 shield	9	T.M.D.S Data 0-	16	SDA
3	T.M.D.S Data 2-	10	T.M.D.S Clock+	17	DDC/CEC GND
4	T.M.D.S Data 1+	11	T.M.D.S Clock shield	18	+5 V Power
5	T.M.D.S Data 1 shield	12	T.M.D.S Clock-	19	Hot Plug Detect
6	T.M.D.S Data 1-	13	Spare (not connected)		
7	T.M.D.S Data 0+	14	Spare (not connected)		

Specification of the mini D-SUB15pin terminal

Connect it to the mini D-SUB15pin output terminal of a video device.

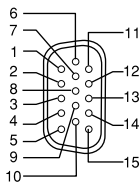

Pin No.	Input signal	Pin No.	Input signal	Pin No.	Input signal
1	Red video signal	7	Green video signal return	13	Horizontal synchronization signal
2	Green video signal	8	Blue video signal return	14	Vertical synchronization signal
3	Blue video signal	9	Not connected	15	I2C clock
4	Not connected	10	Ground		
5	Ground	11	Not connected		
6	Red video signal return	12	I2C data		

Notice on transportation

This monitor is precision equipment and needs dedicated packing material for transportation. Never use any packing material supplied from sources other than JVC or JVC-authorized dealers.

- For easy understanding, pictures and illustrations are shown by being emphasized, omitted or composed, and may be slightly different from actual products.
- Design and specifications are subject to change without notice.
- All company names and product names mentioned herein are used for identification purposes only, and may be the trademarks or registered trademarks of their respective companies.

Краткое руководство пользователя

Задняя панель

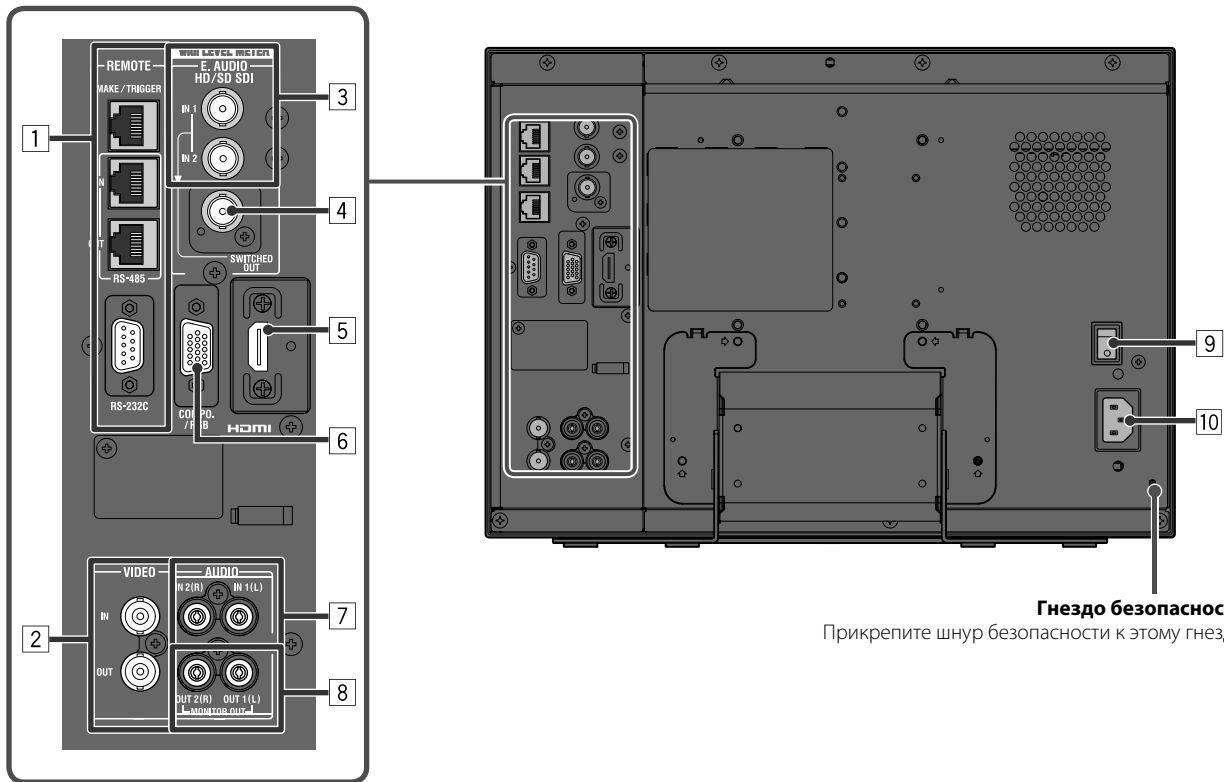

Гнездо безопасности

Прикрепите шнур безопасности к этому гнезду.

1 Разъем REMOTE

Разъем для управления монитором с помощью внешнего устройства.

2 Разъемы VIDEO (BNC)

Входной (IN) и выходной (OUT) разъемы для композитных сигналов.

3 Разъемы E. AUDIO HD/SD SDI (IN 1, IN 2) (BNC)

Входные разъемы для сигналов HD/SD SDI.

● Данные разъемы также принимают сигналы EMBEDDED AUDIO, включающие до 16 звуковых каналов с частотой дискретизации 48 кГц.

4 Разъем E. AUDIO HD/SD SDI (SWITCHED OUT) (BNC)

Выходной разъем для сигналов HD/SD SDI.

● Сигналы SDI текущего входа (SDI 1 или SDI 2) проходят синхронизацию, а затем подаются на выход.

● Когда выбран какой-либо вход кроме SDI 1 и SDI 2, на выход этого разъема подается сигнал SDI входа, выбранного в прошлый раз.

● Сигналы подаются на выход через этот разъем, только когда монитор включен или находится в режиме "Энергосбереж." (энергосбережения).

5 Разъем HDMI

Входной разъем совместим с HDCP для сигнала HDMI.

6 Разъем COMPO./RGB (15-контактный разъем mini D-sub)

Входной разъем для аналогового компонентного сигнала или аналогового сигнала RGB.

● Устанавливайте "Компонентный/RGB" соответственно входным сигналам.

7 Разъемы AUDIO (IN) (штекерное гнездо)

Входные разъемы для аналоговых аудиосигналов.

● Используйте этот разъем для аналогового аудиоподключения SDI. При вводе аудиосигналов через данный разъем установите параметр "Выбрать SDI-1" или "Выбрать SDI-2" в меню на значение "1 канал+2канал", "1-й канал" или "2-й канал".

● При использовании входа HDMI для изображения и аналогового звука для аудиосигнала вводите аналоговый звук через этот разъем и выполните настройку "Выбрать HDMI" в меню на значение "1 канал+2канал", "1-й канал" или "2-й канал".

Краткое руководство пользователя (продолж.)



8 Разъемы AUDIO (MONITOR OUT) (штекерное гнездо)

Выходные разъемы для аналогового аудиосигнала.

- Разъемы выводят аудиосигналы, поступающие с разъема AUDIO (IN) или сигналы EMBEDDED AUDIO, поступающие с входного разъема E. AUDIO HD/SD SDI (IN 1 или IN 2).
- Сигнал выводится через этот разъем, только когда монитор включен или находится в режиме “Энергосбереж.” (энергосбережения).
- Сигнал EMBEDDED AUDIO...
 - декодируется в аналоговый сигнал и затем выводится.
 - выводится, только когда выбрано “SDI 1” или “SDI 2” и когда сигналы EMBEDDED AUDIO поступают на разъем E. AUDIO HD/SD SDI (IN 1 или IN 2).
- Аудиосигналы выводятся через разъем HDMI, только когда сигналы не защищены HDCP.
 - Даже если сигналы защищены HDCP, звук выводится через динамики.

9 Выключатель POWER

Включает и выключает питание от источника переменного тока.

- Чтобы пользоваться монитором после включения выключателя питания POWER, необходимо нажать кнопку  / .

10 Разъем AC IN

Соединительный разъем для подачи питания от источника переменного тока.

Подключите прилагаемый шнур питания от источника переменного тока к розетке переменного тока.

ПРЕДОСТЕРЕЖЕНИЕ

Не подключайте шнур питания до тех пор, пока не будут выполнены все остальные подключения.

Примечание по подключениям

- Перед выполнением подключения выключите все устройства.
- Используйте шнур, штепсельные разъемы которого точно совпадают с разъемами на мониторе и устройствах.
- Штепсельные вилки должны быть прочно и надежно вставлены; плохой контакт может вызвать помехи.
- Отсоединяя шнур, возьмитесь за штепсель и потяните за него.
- НЕ подключайте шнур питания до тех пор, пока не будут выполнены остальные подключения.
- Также см. руководство пользователя для каждого устройства.

Передняя панель

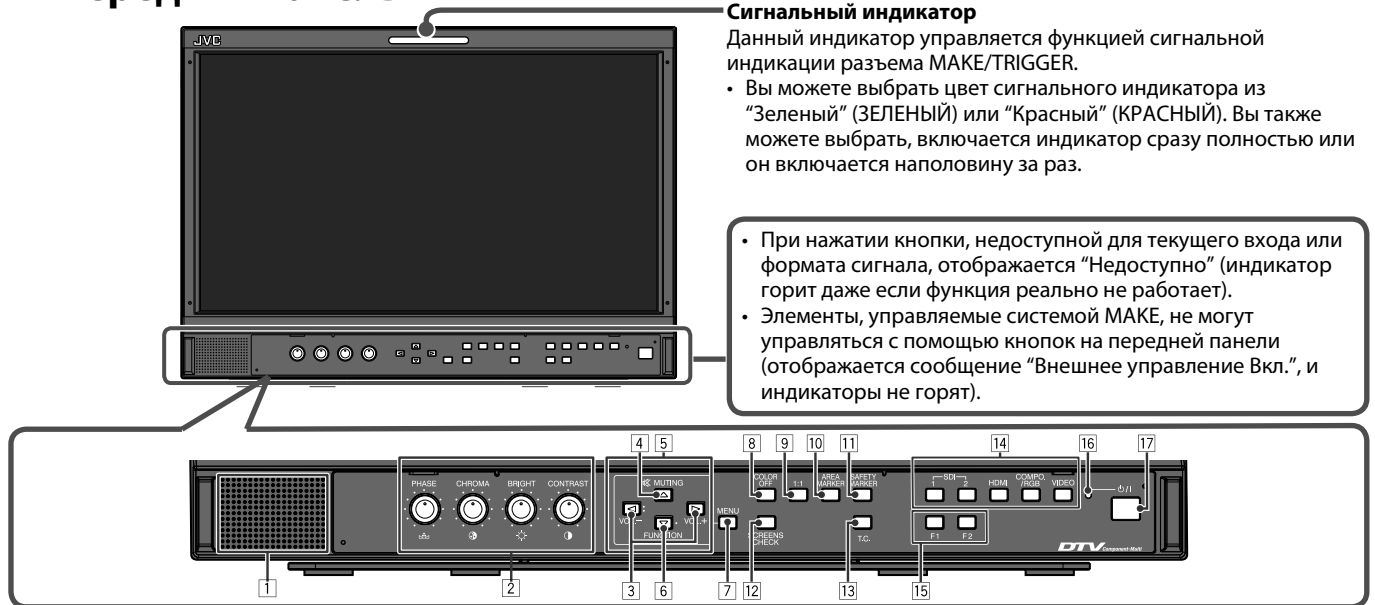

Сигнальный индикатор

Данный индикатор управляется функцией сигнальной индикации разъема MAKE/TRIGGER.

- Вы можете выбрать цвет сигнального индикатора из "Зеленый" (ЗЕЛЕНЫЙ) или "Красный" (КРАСНЫЙ). Вы также можете выбрать, включается индикатор сразу полностью или он включается наполовину за раз.

- При нажатии кнопки, недоступной для текущего входа или формата сигнала, отображается "Недоступно" (индикатор горит даже если функция реально не работает).
- Элементы, управляемые системой MAKE, не могут управляться с помощью кнопок на передней панели (отображается сообщение "Внешнее управление Вкл.", и индикаторы не горят).

1 Динамик (монофонический)

Динамик воспроизводит те же аудиосигналы, которые подаются на выходные разъемы AUDIO (MONITOR OUT).

2 Ручка настройки изображения

- PHASE:** Настройка оттенков изображения
CHROMA: Настройка цветности изображения
BRIGHT: Настройка яркости изображения
CONTRAST: Настройка контрастности изображения
- Параметры PHASE и CHROMA могут не настраиваться для определенных форматов сигнала.
 - Когда для параметра "Компонент фаза" задано значение "Выключить" и на вход поступает сигнал NTSC, можно отрегулировать параметр PHASE.

3 Регулировочная кнопка VOLUME/Кнопка настройки EMBEDDED AUDIO

Настройка уровня громкости, когда не отображается никакой экран меню.
 Выбор звукового канала, когда на входе SDI содержатся сигналы EMBEDDED AUDIO.

4 Кнопка MUTING

- Отключает звук (функция отключения звука).
- Чтобы отменить функцию, нажмите кнопку еще раз.
 - Функция отключения звука также отменяется при регулировке уровня громкости.

5 Кнопки </> / Δ / ▽

Когда отображается экран меню, позволяют выбрать или отрегулировать элементы меню.

6 Кнопка FUNCTION

Назначение функций кнопкам F1 и F2, когда не отображается меню.

7 Кнопка MENU

Включает/выключает отображение Главного меню.

8 Кнопка/индикатор COLOR OFF

Отображает только сигнал яркости.

- Эта функция не работает для входных сигналов RGB.

9 Кнопка/индикатор 1:1

Отображает картинку с изначальным разрешением входного сигнала.

- Форматное соотношение картинок может изменяться в зависимости от входного сигнала.

10 Кнопка/индикатор AREA MARKER

Отображает/скрывает маркер области.

- Выберите тип маркера области в "Маркер" из Главного меню.
- Данная функция работает, только когда картинка отображается в формате 16:9.
- Данная функция не работает, когда для параметра "Маркер области" или "Маркер безопасности - R" установлено значение "Выкл." в "Маркер".

11 Кнопка/индикатор SAFETY MARKER

Отображает/скрывает маркер безопасности.

- Задать область маркера безопасности в элементе меню "Маркер" из Главного меню.

- Данная функция не работает, когда картинка отображается в формате 1:1 и для параметра "Размер SD4:3" в меню установлено значение "Полноразмерный".
- Данная функция не работает, когда для параметра "Сохранить маркер" или "Маркер безопасности - R" установлено значение "Выкл." в "Маркер".

12 Кнопка/индикатор SCREENS CHECK

Отображает только выбранный элемент (R, G или B) видеосигнала.

- Каждый раз с нажатием этой кнопки изображение меняется в следующем порядке.

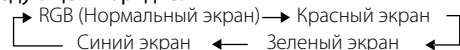

13 Кнопка/индикатор T.C. (временной код)

Включение/выключение отображения временных данных (временного кода), содержащихся в сигнале SDI.

- Выберите тип кода времени в параметре "Информация" из меню Меню настроек.

14 Кнопки/индикаторы INPUT SELECT

Выбор входа.

SDI 1: Разъем E. AUDIO HD/SD SDI (IN 1)
SDI 2: Разъем E. AUDIO HD/SD SDI (IN 2)
HDMI: Разъем HDMI
COMPO./RGB: Разъем COMPO./RGB
VIDEO: Разъем VIDEO

- Загорается индикатор для выбранного входа.

15 Кнопки/индикаторы F1/F2

Вы можете использовать функции, назначенные этой кнопке.

16 Индикатор питания

Индикатор не светится: Монитор полностью отключен (выключен выключатель питания POWER на задней панели) или находится в режиме низкой мощности

Индикатор светится зеленым: Монитор включен

Индикатор светится оранжевым: Монитор отключен (в режиме ожидания)

Индикатор мигает оранжевым: Монитор в режиме Энергосбереж. (энергосбережения).

17 Кнопка ⏻ / I

Включает и выключает питание (переключает монитор в режим ожидания)

- Выключатель питания POWER находится на задней панели монитора.

