



HD MEMORY CARD CAMERA RECORDER

GY-HM890U/GY-HM890E

GY-HM890CHU/GY-HM890CHE

GY-HM890RE/GY-HM890RCHE

GY-HM850U/GY-HM850E

GY-HM850CHU/GY-HM850CHE

GY-HM850RE/GY-HM850RCHE

INSTRUCTIONS

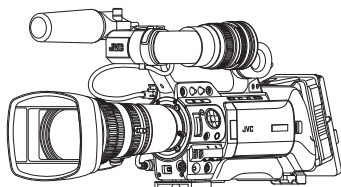

In this illustration, the supplied viewfinder, microphone, and lens are attached to the GY-HM890U/GY-HM890E/GY-HM890RE.

The lens is not supplied for GY-HM890CHU/GY-HM890CHE/GY-HM890RCHE and GY-HM850CHU/GY-HM850CHE/GY-HM850RCHE.

The specifications and appearance of this product are subject to changes for further improvement without prior notice.

Please check the latest version of the INSTRUCTIONS from the following Mobile User Guide. You can also download the PDF from the Mobile User Guide.

Mobile User Guide

When you are outside, you can refer to the instructions from your Android phone or iPhone.

<http://manual3.jvckenwood.com/pro/mobile/global/>

You can view the Mobile User Guide using the browser on your Android phone or iPhone.



For Customer Use:

Enter below the Serial No. which is located on the body.
Retain this information for future reference.

Model No. GY-HM890U / GY-HM890CHU
GY-HM850U / GY-HM850CHU

Serial No. _____

Please read the following before getting started:

Thank you for purchasing this product. Before operating this unit, please read the instructions carefully to ensure the best possible performance.

In this manual, each model number is described without the last letter (U/E) which means the shipping destination. (U: for USA and Canada, E: for Europe) Only "U" models (GY-HM890U/GY-HM890CHU/GY-HM850U/GY-HM850CHU) have been evaluated by UL.

Safety Precautions

IMPORTANT SAFEGUARDS

1. Read all of these instructions.
 2. Save these instructions for later use.
 3. All warnings on the product and in the operating instructions should be adhered to.
 4. Unplug this appliance system from the wall outlet before cleaning. Do not use liquid cleaners or aerosol cleaners. Use a damp cloth for cleaning.
 5. Do not use attachments not recommended by the appliance manufacturer as they may cause hazards.
 6. Do not use this appliance near water - for example, near a bathtub, washbowl, kitchen sink, or laundry tub, in a wet basement, or near a swimming pool, etc.
 7. Do not place this appliance on an unstable cart, stand, or table. The appliance may fall, causing serious injury to a child or adult, and serious damage to the appliance. Use only with a cart or stand recommended by the manufacturer, or sold with the appliance. Wall or shelf mounting should follow the manufacturer's instructions, and should use a mounting kit approved by the manufacturer. An appliance and cart combination should be moved with care. Quick stops, excessive force, and uneven surfaces may cause the appliance and cart combination to overturn.
- 
8. Slots and openings in the cabinet and the back or bottom are provided for ventilation, and to insure reliable operation of the appliance and to protect it from overheating, these openings must not be blocked or covered. The openings should never be blocked by placing the appliance on a bed, sofa, rug, or other similar surface. This appliance should never be placed near or over a radiator or heat register. This appliance should not be placed in a built-in installation such as a bookcase unless proper ventilation is provided.
 9. This appliance should be operated only from the type of power source indicated on the marking label. If you are not sure of the type of power supplied to your home, consult your dealer or local power company. For appliance designed to operate from battery power, refer to the operating instructions.
 10. For added protection for this product during a lightning storm, or when it is left unattended and unused for long periods of time, unplug it from the wall outlet and disconnect the antenna or cable system. This will prevent damage to the product due to lightning and power-line surges.
 11. Do not allow anything to rest on the power cord. Do not locate this appliance where the cord will be abused by persons walking on it.
 12. Follow all warnings and instructions marked on the appliance.
 13. Do not overload wall outlets and extension cords as this can result in fire or electric shock.
 14. Never push objects of any kind into this appliance through cabinet slots as they may touch dangerous voltage points or short out parts that could result in a fire or electric shock. Never spill liquid of any kind on the appliance.

- 15.** Do not attempt to service this appliance yourself as opening or removing covers may expose you to dangerous voltage or other hazards. Refer all servicing to qualified service personnel.
- 16.** Unplug this appliance from the wall outlet and refer servicing to qualified service personnel under the following conditions:
- When the power cord or plug is damaged or frayed.
 - If liquid has been spilled into the appliance.
 - If the appliance has been exposed to rain or water.
 - If the appliance does not operate normally by following the operating instructions. Adjust only those controls that are covered by the operating instructions as improper adjustment of other controls may result in damage and will often require extensive work by a qualified technician to restore the appliance to normal operation.
 - If the appliance has been dropped or the cabinet has been damaged.
 - When the appliance exhibits a distinct change in performance - this indicates a need for service.
- 17.** When replacement parts are required, be sure the service technician has used replacement parts specified by the manufacturer that have the same characteristics as the original part. Unauthorized substitutions may result in fire, electric shock or other hazards.
- 18.** Upon completion of any service or repairs to this appliance, ask the service technician to perform routine safety checks to determine that the appliance is in safe operating condition.

FOR USA AND CANADA**CAUTION**

**RISK OF ELECTRIC SHOCK
DO NOT OPEN**



CAUTION:
TO REDUCE THE RISK OF ELECTRIC SHOCK,
DO NOT REMOVE COVER (OR BACK).
NO USER-SERVICEABLE PARTS INSIDE. REFER SERVICING TO QUALIFIED SERVICE PERSONNEL.



The lightning flash with arrowhead symbol, within an equilateral triangle is intended to alert the user to the presence of uninsulated "dangerous voltage" within the product's enclosure that may be of sufficient magnitude to constitute a risk of electric shock to persons.



The exclamation point within an equilateral triangle is intended to alert the user to the presence of important operating and maintenance (servicing) instructions in the literature accompanying the appliance.

CAUTION:
CHANGES OR MODIFICATIONS NOT APPROVED BY JVC COULD VOID USER'S AUTHORITY TO OPERATE THE EQUIPMENT.

Information for USA

This device complies with part 15 of the FCC Rules. Changes or modifications not approved by JVC KENWOOD could void the user's authority to operate the equipment.

This equipment has been tested and found to comply with the limits for a Class A digital device, pursuant to Part 15 of the FCC Rules. These limits are designed to provide reasonable protection against harmful interference when the equipment is operated in a commercial environment. This equipment generates, uses, and can radiate radio frequency energy and, if not installed and used in accordance with the instruction manual, may cause harmful interference to radio communications. Operation of this equipment in a residential area is likely to cause harmful interference in which case the user will be required to correct the interference at his own expense.

This device complies with Part 15 of the FCC Rules.

Operation is subject to the following two conditions: (1) This device may not cause harmful interference, and (2) this device must accept any interference received, including interference that may cause undesired operation.

Due to design modifications, data given in this instruction book are subject to possible change without prior notice.

POUR CANADA



ATTENTION

RISQUE
D'ELECTROCUTION
NE PAS OUVRIR



ATTENTION:
POUR EVITER TOUT RISQUE
D'ELECTROCUTION NE PAS
OUVRIR LE BOITER. AUCUNE
PIECE INTERIEURE N'EST A
REGLER PAR L'UTILISATEUR. SE
REFERER A UN AGENT QUALIFIE
EN CAS DE PROBLEME.



Le symbole de l'éclair à l'intérieur d'un triangle équilatéral est destiné à alerter l'utilisateur sur la présence d'une "tension dangereuse" non isolée dans le boîtier du produit. Cette tension est suffisante pour provoquer l'électrocution de personnes.



Le point d'exclamation à l'intérieur d'un triangle équilatéral est destiné à alerter l'utilisateur sur la présence d'opérations d'entretien importantes au sujet desquelles des renseignements se trouvent dans le manuel d'instructions.

Ces symboles ne sont utilisés qu'aux Etats-Unis.

CAN ICES-3 A / NMB-3 A

The apparatus shall not be exposed to dripping or splashing and that no objects filled with liquids, such as vases, shall be placed on the apparatus.

WARNING:
TO PREVENT FIRE OR SHOCK HAZARD, DO NOT EXPOSE THIS UNIT TO RAIN OR MOISTURE.

CAUTION:
 This unit should be used with 12V DC only. To prevent electric shocks and fire hazards, do NOT use anyother power source.

AVERTISSEMENT :
POUR EVITER LES RISQUES D'INCENDIE OU D'ELECTROCUTION, NE PAS EXPOSER L'APPAREIL A LA PLUIE NI A L'HUMIDITE.

ATTENTION:
 Ce magnétoscope ne doit être utilisé que sur du courant direct en 12V. Afin d'éviter tout resque d'incendie ou d'électrocution, ne pas utillser d'autres sources d'alimentation électrique.

NOTE:
 The rating plate and safety caution are on the bottom and/or the back of the main unit.

REMARQUE :
 La plaque d'identification et l'avertissement de sécurité se trouvent sous l'appareil et/ou au dos.

CAUTION:
 To prevent electric shock, do not open the cabinet.
 No user serviceable parts inside. Refer servicing to qualified service personnel.

FOR EUROPEAN

WARNING
 This equipment is compliant with Class A of CISPR 32.
 In residential environment this equipment may cause radio interference.

The plastics packaging bags may cause suffocation when they are covered over the head. Tear them open, and keep them away from the reach of infants and children by ensuring that they are disposed of properly.

Dear Customer

This apparatus is in conformance with the valid European directives and standards regarding electromagnetic compatibility and electrical safety. European representative of JVC KENWOOD Corporation is: JVCKENWOOD Deutschland GmbH Konrad-Adenauer-Allee 1-11 61118 Bad Vilbel GERMANY

Sehr geehrter Kunde, sehr geehrte Kundin, dieses Gerät stimmt mit den gültigen europäischen Richtlinien und Normen bezüglich elektromagnetischer Verträglichkeit und elektrischer Sicherheit überein. Die europäische Vertretung für die JVC KENWOOD Corporation ist: JVCKENWOOD Deutschland GmbH Konrad-Adenauer-Allee 1-11 61118 Bad Vilbel DEUTSCHLAND

FOR EUROPE

- This equipment is in conformity with the provisions and protection requirements of the corresponding European Directives. This equipment is designed for professional video appliances and can be used in the following environments:

Controlled EMC environment (for example, purpose-built broad-casting or recording studio), and rural outdoors environments.

In order to keep the best performance and furthermore for electromagnetic compatibility we recommend to use cables not exceeding the following lengths:

Terminal	Cable	Length
[DC INPUT]	Exclusive Cable	5 m
[VIDEO OUT]	Coaxial Cable	10 m
[INPUT1/INPUT2]	Shielded Cable	3 m
[AUDIO OUTPUT CH-1/3]	Shielded Cable	10 m
[AUDIO OUTPUT CH-2/4]	Shielded Cable	10 m
[AUX]	Shielded Cable	5 m
[PHONES]	Exclusive Cable	3 m
[HDMI]	Shielded Cable	3 m
[HD/SD SDI IN] 890 890CH	Coaxial Cable	10 m
[HD/SD SDI OUT]	Coaxial Cable	10 m
[REMOTE1]	Exclusive Cable	5 m
[REMOTE2]	Exclusive Cable	1 m
[LENS]	Unshielded Cable	0.1 m
[VF]	Special cable	0.3 m
[DEVICE]	Shielded Cable	2 m
[GENLOCK]	Coaxial Cable	10 m
[TC IN]	Coaxial Cable	10 m
[TC OUT]	Coaxial Cable	10 m
[STUDIO] 890 890CH	Exclusive Cable	0.3 m

Caution:

Where there are strong electromagnetic waves or magnetism, for example near a radio or TV transmitter, transformer, motor, etc., the picture and the sound may be disturbed. In such case, please keep the apparatus away from the sources of the disturbance.

■ Para Brasil

Informação sobre eliminação de baterias

Este produto não deverá ser eliminado como lixo doméstico em geral. Devolva a bateria velha ao comerciante ou para a rede autorizada, para que seja devolvida ao fabricante ou importador. A reciclagem e eliminação de lixo em uma maneira adequada, ajudarão para preservar recursos, prevenindo, ao mesmo tempo, contra efeitos prejudiciais sobre a nossa saúde e o meio ambiente.

Importer (EU only)

JVCKENWOOD U.K. Limited
12 Priestley Way, London NW2 7BA,
UNITED KINGDOM

Importeur (Nur EU)

JVCKENWOOD Deutschland GmbH
Konrad-Adenauer-Allee 1-11, 61118 Bad Vilbel,
DEUTSCHLAND

Importatore (Solo EU)

JVCKENWOOD Italia S.p.A.
Via G. Sirtori 7/9, 20129 Milano, ITALIA

Importador (Solamente EU)

JVCKENWOOD Ibérica, S.A.
Ctra. Rubi, 88 Edificio Can Castanyer, 08174
Sant Cugat del Valles, Barcelona, ESPAÑA

Importeur (Aleen EU)

JVCKENWOOD Belgium N.V.
Leuvensesteenweg 248J, 1800 Vilvoorde,
BELGIQUE

Importeur (Aleen EU)

JVCKENWOOD Europe B.V.
Amsterdamseweg 37, 1422 AC Uithoorn,
NEDERLAND

Manufacturer

JVCKENWOOD Corporation

3-12, Moriya-cho, Kanagawa-ku, Yokohama-shi,
Kanagawa, 221-0022, JAPAN

关于环保使用期限



环保使用期限

- 此图标表示了中华人民共和国的法律所规定的环保使用期限。只要用户在使用本产品时遵守注意事项中的各项规定，从制造日期开始到此图标标出的期限为止（环保使用期限）既不会污染环境也不会产生对人体有害的物质。
- 附件和消耗性零件的环保使用期限如下所示：
（不同产品中包含的附件和消耗性零件也不相同。）
遥控器、交流转换器、电缆类：10年
电池包：5年

关于产品中的有害物质

部件名称	有害物质					
	铅 (Pb)	汞 (Hg)	镉 (Cd)	六价铬 (Cr(VI))	多溴联苯 (PBB)	多溴二苯醚 (PBDE)
线路板组件	×	○	○	×	○	○
机箱	×	○	○	×	○	○
光学系统	×	○	○	×	○	○
液晶显示屏模块	×	○	○	×	○	○
其他附件	×	○	○	×	○	○

本表格依据 SJ/T11364 的规定编制。

- ：表示该有害物质在该部件所有均质材料中的含量均在 GB/T26572 规定的限量要求以下。
- ×：表示该有害物质至少在该部件的某一均质材料中的含量超出 GB/T26572 规定的限量要求。

Contents

	Clips Recorded to SD Cards	47
	About the Operation Lock Feature	48
Introduction		
Safety Precautions	3	
Contents	9	
Main Features	12	
Precautions for Proper Use	14	
Operation Modes	18	
Names of Parts	20	
Side Control Panel	22	
Viewfinder	23	
LCD Monitor	24	
Side Terminal Section	24	
SD Slot	25	
Rear Terminal	25	
Lens Section 890 850	26	
Basic System Diagram	27	
Preparations		
Settings and Adjustments Before Use	28	
Attaching the Lens (Supplied)	28	
Adjusting the Grip Belt 890 850	28	
Attaching the Microphone (Supplied)	28	
Attaching the Viewfinder (Supplied)	28	
Opening/Closing the Lens Cover 890 850	29	
Attaching/Detaching the Hood 890 850	29	
Attaching the Anti-reflective Film	30	
Power Supply	30	
Using AC Power (DC IN Power)	30	
Using a Battery Pack	31	
Power Status Display	32	
Turning On/Off the Power	33	
Initial Settings	34	
Displays on the LCD Monitor and Viewfinder	36	
Display Screen	36	
Status Screen	37	
USB Mode Screen	38	
Remote Edit Mode Screen	38	
Warning Display	38	
Adjusting the LCD Monitor and Viewfinder	38	
Adjusting the LCD Monitor	39	
Adjusting the Viewfinder	40	
Adjusting the Monitor Speaker	40	
Adjusting Back Focus	41	
Assignment of Functions to User Buttons	42	
Tally Lamp	42	
SD Card	43	
Usable Cards	43	
Formatting (Initializing) SD Cards	45	
Restoring and Updating the SD Card	46	
Shooting		
Basic Shooting Procedures	49	
Selecting a Recording Format	50	
Zoom Operation	52	
Focus Operation LENS	53	
Adjusting the Focus by Face Detection LENS	56	
Adjusting the Brightness	57	
Adjusting the Iris	58	
Setting the Gain	59	
Setting the Electronic Shutter	60	
Setting the ND Filter	62	
Adjusting the White Balance	63	
Adjusting the Camera Image	68	
Using the Image Stabilizer LENS	68	
Audio Recording	69	
Audio Output during Recording	72	
Time Code and User's Bit	72	
Setting Time Code Generator	73	
Setting the User's Bit	76	
Synchronizing the Time Code with an External Time Code Generator	78	
Setting Zebra Pattern	79	
Setting Spot Meter	80	
Acquiring Positioning Information by GPS GPS	82	
Viewing Recorded Videos Immediately (Clip Review)	83	
Using the Histogram	84	
Recording Simultaneously at Two Different Definitions	84	
Splitting the Clips Freely (Clip Cutter Trig)	85	
Dual Rec	85	
Backup Rec	87	
Special Recording	89	
Pre Rec	89	
Clip Continuous Rec	89	
Frame Rec	91	
Interval Rec	92	
Variable Frame Rec	93	
Playback		
Playing Recorded Clips	94	
Thumbnail Screen	94	
Actions	96	
Playing back	97	
Deleting Clips	98	
Appending/Deleting OK Mark	99	
Selecting and Performing Operations on Multiple Clips	100	

Selecting Multiple Clips Randomly	100	Connecting Wired Remote Control	164
Selecting Multiple Clips Consecutively	101	Connecting a Remote Control Unit	164
Trimming Recorded Clips	102	Functions Operable from the Remote Control Unit	166
Menu Display and Detailed Settings		Inputting SDI Signals from an External Device 890 890CH	168
Basic Operations in Menu Screen	103	Inputting External Synchronizing Signals (Genlock)	169
Display and Description of the Menu Screen	104	Displaying Return Videos from an External Device 890 890CH	172
Text Input with Software Keyboard	105	Studio System 890 890CH	172
About the Menu Lock Feature	106	Connecting to the Network	
Menu Screen Hierarchical Chart	107	Functions of Network Connection	174
Camera Function Menu	108	Preparing Network Connection	174
User Switch Set Item	111	Operating Environment	174
FULL AUTO Item	113	Camera Setup for Network Connection	175
Camera Process Menu	114	Connecting via Wireless LAN	175
Detail/Adjust Item	117	Connecting via Wired LAN	177
White Balance Item	118	Connecting via Cellular Adapter	177
TC/UB Menu	119	Importing Metadata	178
LCD/VF Menu	120	Preparing Metadata	178
Shooting Assist Item	121	Configuring the Server for Downloading	178
Marker Settings Item	121	Importing Metadata	179
Display Settings Item	122	Uploading a Recorded Video Clip	180
A/V Set Menu	125	Configuring the FTP Server for Uploading	180
Video Set Item	125	Uploading Video Clip	180
Audio Set Item	127	Connecting from a Web Browser	182
System Menu	130	Editing Metadata	183
Record Set Item	132	Planning Metadata	183
Network/Settings Item	137	Clip Metadata	184
Adding/Editing Frequently Used Menu Items	142	Uploading a Recording Clip via a Web Browser	187
Registration to Favorites Menu	142	View Remote Feature	190
Editing Favorites Menu	143	Operating Procedure	190
Display/Status Screen		Registering/Deleting Preset Zoom	191
Display Screen in Camera Mode	145	Camera Control Function	193
Display Screen in Media Mode	151	Changing the Settings via a Web Browser	194
Status Screen	153	Changing View Remote Function Settings	195
Camera Features		Changing Connection Setup	196
Marker and Safety Zone Displays	154	Changing Metadata Server Settings	197
Smoothing the Skin Color (Skin Detail Function)	155	Changing Clip Server Settings	197
Color Bar Output	155	Changing Streaming Settings	197
Adjusting Color Matrix	156	Managing the Network Connection Settings File	197
Configuring Setup Files	157	Saving the Connection Settings File	197
Saving Setup Files	157	Reading the Connection Settings File	198
Loading a Setup File	158	Deleting Connection Settings	199
Deleting Setup Files	159	Performing Live Streaming	199
Connecting External Devices		Setting Distribution	200
Managing/Editing Clips on a PC	160	Starting Distribution	200
Connecting External Monitor	161		
Connecting a Earphone	163		

Others

Error Messages and Actions	202
List of FTP Transfer Errors	203
List of Live Streaming Error Displays	205
Blinking of the Tally Lamp	206
Warning Tone	206
Troubleshooting	206
Specifications	209
Index	214
Software License Agreement	216
Important Notice concerning the Software	217
Open Source License	218

Main Features

Inheriting the compact shoulder-carry style

Inheriting the compact shoulder-carry style of the GY-HM700 series, this camera recorder enables more stable shooting while maintaining the same weight as handheld models.

F11 Sensitivity, 1/3-inch Full HD 3CMOS Sensors

This camera recorder is equipped with three 1/3-inch 2.07M pixels full HD CMOS sensors. It delivers high image quality with a high color resolution through the processing of individual R, G, B color signals. 12-bit signal processing and the new 2D DNR removes dark current and optical shot noise without losing S/N and high resolution, thereby achieving high F11 sensitivity.

Equipped with the newly-developed Fujinon 20x interchangeable zoom lens with AF/OIS 890 850

It ensures high magnification of 29 mm at wide ends, and provides high sensitivity across all regions with F1.6-3.0.

This interchangeable lens comes with an autofocus (AF) and Optical Image Stabilizer (OIS) function, allowing for stable focusing when used as a shoulder-carry camera recorder.

In addition to the central area, it also comes with a face-detection autofocus feature, and supports switching to manual focusing.

The zoom ring with zoom ring pin enables zooming from the wide end to the tele end in 90 degrees.

Focus and iris control are also possible using separate rings.

4-position ND Filter

This camera recorder incorporates three types of ND filters.

Adjust the amount of light according to the brightness during shooting by switching the 4-position ND filter (OFF, 1/4, 1/16, 1/64).

JVC's Proprietary FALCONBRID High-Quality Imaging Engine

The FALCONBRID high-quality imaging engine omits unnecessary processing through incorporating camera processing and image compression on a single chip. Images from imaging devices are compressed and processed without any loss thereby achieving high-quality images.

MPEG2 and H.264 Codec

FALCONBRID allows users to select a recording format such as MPEG-2, H.264 and AVCHD Progressive, the most commonly used codec for professional videos.

50 Mbps high-resolution recording mode

This camera recorder comes with a 50 Mbps mode in the H.264 format (1920x1080: MOV) to support high-resolution video recording.

QuickTime (MPEG-2 HD/H.264 HD/H.264 SD)/MP4 (MPEG-2 HD)/AVCHD File Formats

Inheriting the concept of ProHD memory camera recorders, this camera recorder also supports various file formats, such as AVCHD and QuickTime (H.264 SD) files, as well as QuickTime (MPEG-2 HD/H.264 HD) files that can be directly edited on Apple Final Cut Pro, in addition to MP4 files that are most suitable for XDCAM EX Nonlinear Editing Workflow.

Two SDHC/SDXC Card Slots for Dual, Backup and Series Recording

The most common SDHC/SDXC card recording system is used as the memory card.

This ensures reliability and operation at low running cost.

Various user friendly recording systems are also available. These include dual recording of the same file to two cards, and using REC/STBY to break up video clips in one card while performing backup recording to the other card.

Diverse simultaneous recording combinations (HD and SD, HD and Proxy Video, etc.)

This camera recorder is equipped with a proxy video (960x540: MOV, 480x270: MOV, 1440x1080: AVCHD) recording function that is convenient for network distribution.

Further enhancements were made to the dual recording feature, allowing for HD recording to one of the SDHC/SDXC cards, and SD or proxy video recording to the other card at the same time.

Variable frame recording

Enables beautiful slow motion and quick motion image recording such as overcrank and undercrank.

The ability to change the frame rate during recording enables quick to gradually slow motion effects.

Pre Rec function (up to 10 seconds) and Interval Rec function

SDI/HDMI Simultaneous Output

Equipped with both [HD/SD SDI] and [HDMI] terminals as digital output. Non-compressed full HD video signals and audio signals can be output to the [HD/SD SDI] and [HDMI] terminals at the same time.

Comes with genlock input and time code input/output terminals

This camera recorder supports the use of multiple cameras as well as studio use.

Professional Switch Layout and Various Video Parameter Settings

Switches for Gain and White Balance are available on the side panel to enable quick switching according to the shooting scene. Image parameters such as gamma and color matrixes are also available in the menu for adjusting preferred tones.

0.45-inch 1.22-megapixel color viewfinder, 4.3-inch 1.15-megapixel LCD display (Equipped with Focus Assist function)

4-channel audio

Supports 4-channel audio in the MPEG-2/H.264 recording mode. In addition to two mic inputs, you can also record audio input from the [AUX] input terminal to an independent track.

2-channel XLR audio input (microphone/line switch, phantom power supply) and mini jack input terminal for wireless microphone receiver

Supports two types of wired remote control units

In addition to JVC's original 6-pin remote terminal, this camera recorder is also equipped with a Φ 2.5mm stereo jack remote control terminal.

Built-in GPS

This camera recorder is built in with a GPS function, which enables the positional information obtained from the GPS satellite during a shoot to be recorded as metadata.

* Note that acquisition of the positional information may fail depending on the weather condition.

Diverse Network Functions

This camera recorder supports functions such as remote control from a mobile device, viewing, metadata transmission, and proxy file transfer as an FTP client.

Equipped with a USB host function, you can upload recorded files stored in this unit via a network by connecting it to network devices such as a wireless LAN adapter (optional). Video and audio streaming is also supported.

Professional-spec battery

This camera recorder supports the use of batteries used by broadcasting stations, such as Anton/Bauer and IDX batteries.

(Gold Mount: For use with Anton/Bauer battery (U model), V Mount: For use with IDX battery (E model))







Application Software Provided

The [JVC ProHD Clip Manager] application software is provided for you to copy recorded clips to Windows or Macintosh computers and for checking the video images. (For MP4 file format)

The disc provided with this camera recorder comes with [JVC ProHD Clip Manager] and other application software as well as their user guides.

* For details, refer to the user guides for each application software.

Symbols used

- Caution : Describes precautions concerning the operation of this product.
- Memo : Describes reference information, such as functions and usage restrictions of this product.
-  : Indicates the reference page numbers and reference items.
-  : Feature available on GY-HM890U/GY-HM890E/GY-HM890RE only.
-  : Feature available on GY-HM890CHU/GY-HM890CHE/GY-HM890RCHE only.
-  : Feature available on GY-HM850U/GY-HM850E/GY-HM850RE only.
-  : Feature available on GY-HM850CHU/GY-HM850CHE/GY-HM850RCHE only.
-  : Feature available on models with built-in GPS only (GY-HM890U/GY-HM890E/GY-HM890CHU/GY-HM890CHE/GY-HM850U/GY-HM850E/GY-HM850CHU/GY-HM850CHE).
-  : Feature available only with the supplied lens.

Content of this manual

- All rights reserved by JVC KENWOOD Corporation. Unauthorized duplication or reprinting of this manual, in whole or in part, is strictly prohibited.
- Illustrated designs, specifications and other contents of this manual are subject to change for improvement without prior notice.
- AVCHD Progressive and the AVCHD Progressive logo are trademarks of Panasonic Corporation and Sony Corporation.
- XDCAM EX is a trademark of Sony Corporation.
- SDXC and SDHC logos are trademarks of SD-3C, LLC.
- HDMI (High-Definition Multimedia Interface) and  are trademarks of HDMI Licensing, LLC.
- QuickTime, Final Cut Pro, iPhone, iPad, iPod touch, iOS, Mac OS and Safari are trademarks of Apple Inc., registered in the U.S. and other countries.
- Android and Google Chrome are trademarks and/or registered trademarks of Google Inc.
- QR Code is a registered trademark of Denso Wave Incorporated.
- Dolby and the double-D symbol are trademarks of Dolby Laboratories.
- Microsoft, Windows, Windows XP, Windows Vista, Windows 7, Windows 8, and Internet Explorer are registered trademarks of Microsoft Corporation in the United States and/or other countries.
- Mozilla and Firefox are either trademarks or registered trademarks of Mozilla Foundation in the United States and/or other countries.
- Intel Core 2 Duo is a trademark or registered trademark of Intel Corporation or its subsidiaries in the United States and other countries.
- The company name of Fontworks, Fontworks, and the name of the fonts are registered trademarks of Fontworks Inc.
- Other product and company names included in this instruction manual are trademarks and/or registered trademarks of their respective companies. Marks such as TM and ® have been omitted in this manual.

Precautions for Proper Use

| Storage and Usage Locations

- Allowable ambient temperature and humidity
Be sure to use this unit within the allowable temperature range of 0 °C to 40 °C (32 °F to 104°F) and a relative humidity of 35 % to 80 %. Using this unit at a temperature or humidity outside the allowable ranges could result not only in malfunction but also serious impact on the CMOS elements as small white spots may be generated. Please exercise care during use.
- Strong electromagnetic waves or magnetism
Noise may appear in the picture or audio and/or the colors may be incorrect if this unit is used near a radio or television transmitting antenna, in places where strong magnetic fields are generated by transformers, motors, etc., or near devices emitting radio waves, such as transceivers or cellular phones.
- Use of wireless microphone near this unit
When a wireless microphone or wireless microphone tuner is used near this unit during recording, the tuner could pick up noise.
- Avoid using or placing this unit in the following places.
 - Places subject to extreme heat or cold
 - Places with excessive dirt or dust
 - Places with high humidity or moisture
 - Places subject to smoke or vapor such as near a cooking stove
 - Places subject to strong vibrations or unstable surfaces
 - In a parked car under direct sunlight or near a heater for long hours
- Do not place this unit at places that are subject to radiation or X-rays, or where corrosive gases occur.
- Protect this unit from being splashed with water. (Especially when shooting in the rain)
- Protect this unit from getting wet when shooting on a beach. In addition, salt and sand may adhere to the body. Clean the unit after use.
- Protect this unit against penetration of dust when using it in a place subject to sandy dust.

Carrying the Camera

Do not drop or hit this unit against a hard object when transporting.

Power Saving

When this unit is not in use, be sure to set the [POWER ON/OFF] switch to "OFF" in order to reduce power consumption.

Maintenance

- Turn off the power before performing any maintenance.
- Wipe the external cabinet of the unit with a soft cloth. Do not wipe the body with benzene or thinner. Doing so may cause the surface to melt or turn cloudy. When it is extremely dirty, soak the cloth in a solution of neutral detergent, wipe the body with it, and then use a clean cloth to remove the detergent.

Batteries

- The batteries recommended for use with this camera recorder are as follows.
U model : Dionic90 (Anton/Bauer)
E model : Endura-HL9 (IDX)
- Please make use of one of the recommended batteries.
Heavy batteries may fall off if they are not used correctly.

Regular Inspection (Maintenance)

Under normal environment, dust will accumulate on the camera recorder when it is used over a long period. Dust may enter the camera recorder especially if it is used outdoors. This may affect the image and sound quality of the camera recorder. Check and replace the fan after every 9000 hours (suggested guideline).

You can check the usage time of the fan in [System] → [System Information] → [Fan Hour].

(☞ P132 [Fan Hour])

If the fan is used for more than 9000 hours without replacement, "Fan Maintenance Required" will be displayed every time you turn on the power.

GPS

- The GPS (Global Positioning System) satellites are managed by the Department of State of the U.S., and its precision may be altered intentionally.
- Perform positioning at an unobstructed location with a clear view that is not indoors or blocked by trees.
- The time needed for obtaining the position information may be longer and variation may also be larger depending on the surrounding environment and time of day.
- This camera recorder uses the WGS 84 World Geodetic System.
- Signal from GPS satellites may be interrupted by communication signal from electronic devices such as mobile phones.

LCD Monitor and Viewfinder

- The LCD monitor and viewfinder screen are manufactured using high-precision technology. Black spots may appear on the LCD monitor and viewfinder screen, or red, blue, and/or white spots may not disappear. However, this is not a malfunction and these spots are not recorded on the SD card.
- If you use this unit continuously for a long period of time, the characters displayed in the viewfinder may temporarily remain on the screen. This is not recorded on the SD card. They will not appear after you turn the power off and then on again.
- If you use this unit in a cold place, the images may appear to lag on the screen, but this is not a malfunction. Retained images are not recorded on the SD card.
- Do not press against the surface with force or subject it to strong impact. Doing so may damage or break the screens.
- Noise may appear in the viewfinder when switching between the live video and playback images.
- Due to the characteristic of the viewfinder display device, colors may appear on the images when you blink your eyes. It does not affect the recorded images, SDI output, or HDMI output.

SDHC/SDXC Cards

■ SDHC/SDXC card is referred to as “SD card” in this manual.

■ This camera recorder saves the recorded images and audio sound on the SD card (sold separately) in the card slot.

■ Use an SD card (4 GB to 128 GB) with Class 6 or higher performance, formatted using this camera recorder.

* Depending on the recording format, SD card with Class 4 or higher performance can also be used. Some recording formats supports only the use of cards with Class 10 or higher.

( P50 [Selecting a Recording Format])

* Using cards other than those from Panasonic, TOSHIBA or SanDisk may result in recording failure or data loss.

■ If the SD card contains files recorded by devices other than this camera recorder or files that are saved from a PC, the recordable time may be shorter or data may not be properly recorded. In addition, the remaining space on the card may not increase even when files are deleted using a PC.

Handling of SD Cards

■ The status indicator lights up in red when data on the SD card is being accessed. Do not remove the SD card during data access (such as recording, playback, or formatting). Do not turn off the power or remove the battery and AC adapter during access either.

■ Do not use or store the SD card in a place that is subject to static electricity or electrical noise.

■ Do not place the SD card near locations that are exposed to strong magnetic fields or radio waves.

■ Inserting the SD card incorrectly may result in damage of this unit or the SD card.

■ We are not liable for any accidental loss of data stored on the SD card. Please back up any important data.

■ Make use of the SD card within the prescribed conditions of use.

Do not use it at the following locations.

Places that are subject to direct sunlight, high humidity or corrosion, places near thermal equipment, sandy or dusty places, or in a car under the sun with the doors and windows closed.

■ Do not bend or drop the SD card, or subject it to strong impact or vibration.

■ Do not splash the SD card with water.

■ Do not dismantle or modify the SD card.

■ Do not touch the terminals with your hands or with a metal object.

■ Do not allow dust, dirt, water, or foreign objects to adhere to the terminals.

■ Do not remove the labels or stick other labels or stickers on the SD cards.

■ Do not use pencils or ballpoint pens to write on the SD cards. Always use oil-based pens.

■ If you format (initialize) the SD card, all data recorded on the card, including video data and setup files, will be deleted.

■ You are recommended to use cards that are formatted (initialized) on this camera recorder.

- The SD card may be damaged if the camera recorder is not operated correctly. Formatting (Initializing) the SD card may allow it to operate correctly.

- SD cards that have been formatted (initialized) on other cameras, computers or peripheral equipment may not operate correctly. In this case, format (initialize) the SD card on this camera recorder.

■ If you want to wipe out all information by completely erasing the data, we recommend either using commercially available software that is specially designed for that purpose, or by physically destroying the SD card with a hammer, etc. When formatting or erasing data using the camera recorder, only the file administration information is changed. The data is not completely erased from the SD card.

■ Some commercially available SD cards may be harder to be removed from this unit. Remove them by hooking onto the groove on the cards.

- It will be easier to remove the cards after several times.
- Do not stick any stickers on the cards.



■ The SD card may pop out when it is being removed. Be careful not to lose the card.

Copyright

Any recordings made on this camera recorder that are played back for profit or public preview may infringe on the rights of the owner of the recordings. Do not use the recordings for purpose other than personal enjoyment without prior consent from the owner.

License Notices

■ MPEG LA AVC

THIS PRODUCT IS LICENSED UNDER THE AVC PATENT PORTFOLIO LICENSE FOR THE PERSONAL USE OF A CONSUMER OR OTHER USES IN WHICH IT DOES NOT RECEIVE REMUNERATION TO (i) ENCODE VIDEO IN COMPLIANCE WITH THE AVC STANDARD ("AVC VIDEO") AND/OR (ii) DECODE AVC VIDEO THAT WAS ENCODED BY A CONSUMER ENGAGED IN A PERSONAL ACTIVITY AND/OR WAS OBTAINED FROM A VIDEO PROVIDER LICENSED TO PROVIDE AVC VIDEO. NO LICENSE IS GRANTED OR SHALL BE IMPLIED FOR ANY OTHER USE. ADDITIONAL INFORMATION MAY BE OBTAINED FROM MPEG LA, L.L.C. SEE

[HTTP://WWW.MPEGLA.COM](http://www.mpegla.com)

■ MPEG LA MPEG-2 Patent

ANY USE OF THIS UNIT IN ANY MANNER OTHER THAN PERSONAL USE THAT COMPLIES WITH THE MPEG-2 STANDARD FOR ENCODING VIDEO INFORMATION FOR PACKAGED MEDIA IS EXPRESSLY PROHIBITED WITHOUT A LICENSE UNDER APPLICABLE PATENTS IN THE MPEG-2 PATENT PORTFOLIO, WHICH LICENSE IS AVAILABLE FROM MPEG LA, LLC, 6312 S. Fiddlers Green circle, Suite 400E, Greenwood Village, Colorado 80111 U.S.A.

Encryption in Network Connection

Wireless LAN connections make use of an encryption function.

This encryption is designed for commercially-sold equipment, and it cannot be altered.

Others

- Do not insert objects other than the memory card into the card slot.
- Do not block the vent on the unit. Blocking of the vent causes internal heating and may lead to burns and fires.
- Do not turn off the [POWER ON/OFF] switch or remove the power cable during recording or playback.
- The camera recorder may not show stable pictures for a few seconds immediately after the power is turned on, but this is not a malfunction.
- When the video signal output terminals are not in use, put on the covers to prevent damage to the terminals.
- Do not drop this unit or subject it to strong impact or vibration as it is a precision equipment.
- Optical performance of lens
Due to the optical performance of the lens, color divergence phenomena (magnification chromatic aberration) may occur at the periphery of the image. This is not a camera malfunction.
- Noise may appear in the image when switching modes.
- If placed on its side, heat release efficiency will deteriorate.
- When the connectors that come with connector covers are not in use, put on the covers to prevent damage to the connectors.
- This camera recorder makes use of fonts by Fontworks Inc.
- This camera recorder makes use of M+ FONTS.

Operation Modes

This camera recorder has four operation modes - Camera mode, Media mode, USB mode and Remote Edit mode.

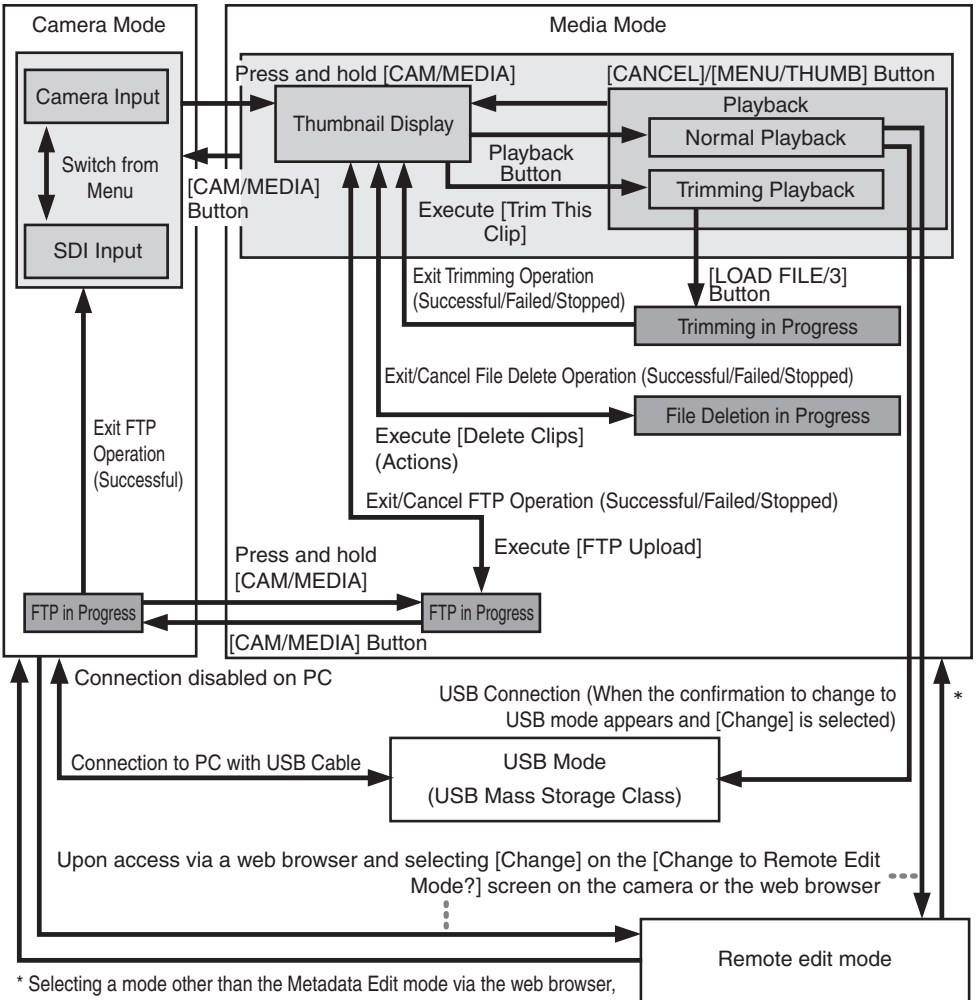

* Selecting a mode other than the Metadata Edit mode via the web browser, or selecting [Exit] on the [Remote Edit Mode] screen

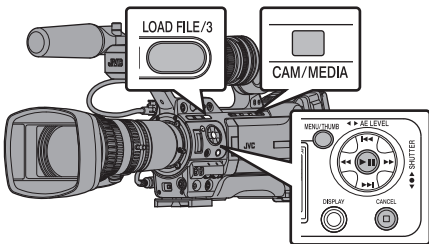

Operation Mode	Description
Camera Mode	<ul style="list-style-type: none"> • This is the camera shooting mode. The camera recorder starts up in Camera mode when the power is turned on. • Camera images are output on the viewfinder and LCD monitor. When a recordable SD card is inserted, the camera recorder enters the recording standby mode. "STBY" appears on the operation mode display area of the LCD monitor and viewfinder. • Press the [REC] trigger button to start recording. • When [System] → [Record Set] → [Record Format] → [System] is set to "HD(SDI In)" or "SD(SDI In)", and the device is connected to the [SDI IN] terminal, the SDI input video is displayed on the LCD monitor or viewfinder. 890 890CH (☞ P168 [Inputting SDI Signals from an External Device 890 890CH]) <hr/> <p>Memo : —</p> <ul style="list-style-type: none"> • Playback of SD card is not possible in Camera mode. However, you can check the most recently recorded video clip. (☞ P83 [Viewing Recorded Videos Immediately (Clip Review)])
Media Mode	<ul style="list-style-type: none"> • This mode allows you to play back or delete clips recorded on the SD card. • When a playable SD card is inserted, the thumbnail or playback screen is displayed on the viewfinder and LCD monitor. • Press and hold the [CAM/MEDIA] selection button to enter the Media mode when you are not shooting in the Camera mode. Once the camera recorder is in Media mode, thumbnails of the selected media slot are displayed.
USB Mode	<ul style="list-style-type: none"> • This mode allows you to connect to a PC and transfer the files on an SD card to the PC. (Writing is not allowed) • When the camera recorder is connected to a USB cable, the message "Change to USB Mode?" appears. Select [Change] and press the Set button to switch to USB mode. (☞ P160 [Managing/Editing Clips on a PC]) • In USB mode, the camera recorder is recognized by the connected PC as a peripheral drive. (USB mass storage class only) Disable the connection on the PC and remove the USB cable from the camera recorder to switch to Camera mode. (☞ P160 [Managing/Editing Clips on a PC]) <hr/> <p>Memo : —</p> <ul style="list-style-type: none"> • When a USB cable is connected during recording, the message appears after recording stops. • If playback is in progress, the message appears once the files are closed automatically, such as when playback stops. • Files on the PC cannot be written to the SD card.
Remote Edit Mode	<ul style="list-style-type: none"> • This mode enables the list display and editing of the recorded clip data through access to the clip list display page via a web browser on a smartphone, tablet terminal, or PC. • When you access via a web browser on a smartphone, tablet terminal, or PC, "It is necessary to change the camera mode to "Remote Edit Mode". Change the mode." appears on the web browser. Also, "Change to Remote Edit Mode?" is displayed on the display screen of the camera unit. Selecting [Change] on the camera recorder and pressing the Set button switches to the Remote Edit mode, and enables display of the clip list and editing of the clip metadata. (☞ P184 [Clip Metadata]) (☞ P187 [Uploading a Recording Clip via a Web Browser]) <hr/> <p>Memo : —</p> <ul style="list-style-type: none"> • If you access via a web browser on devices such as a smartphone, tablet terminal, or PC while recording is in progress, the message appears after recording stops. • If playback is in progress, the message appears once the files are closed automatically, such as when playback stops.

Names of Parts

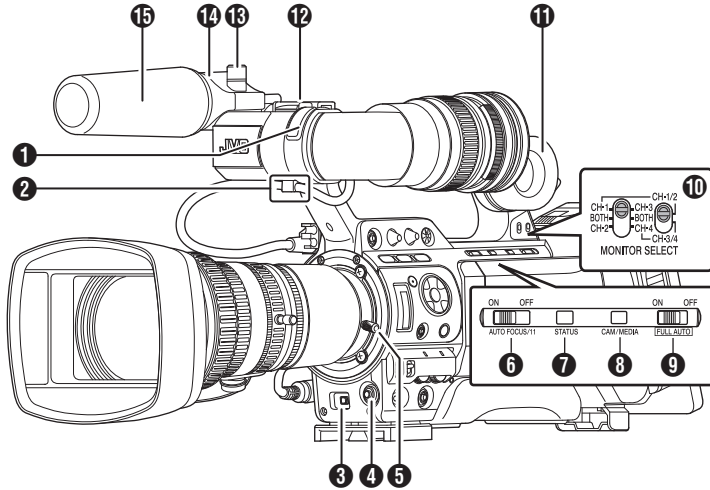

- 1** Front Tally Lamp
 (☞ P42 [Tally Lamp])
 (☞ P206 [Blinking of the Tally Lamp])
- 2** Viewfinder Cable Clamp
 (☞ P28 [Attaching the Viewfinder (Supplied)])
- 3** Cross-Shaped Button (▲▼◆▶)/Set Button (●)
 The function changes according to the operation status of the camera recorder.

 - During menu operation (all modes)
 (☞ P103 [Basic Operations in Menu Screen])

Center Set button (●) : Confirms menu items and setting values

Cross-Shaped Button : Selects menu items and setting values (▲▼◆▶)

 - During Camera mode
 [5/▲][▼/6][7/◀]/ZEBRA[8/▶]/SPOT METER] : You can also use it as a user button by assigning a specific feature in the menu setting to this button.

(☞ P42 [Assignment of Functions to User Buttons])
 (☞ P79 [Setting Zebra Pattern])
 (☞ P80 [Setting Spot Meter])
- 4** [AWB/9] Auto White Balance/User 9 Button

 - Auto White Balance starts up when the [WHT.BAL B/A/PRESET] switch **10** on the operation panel located at the right side of this unit is set to “A” or “B”.
- It is used to switch the color temperature of the preset white balance when the [WHT.BAL B/A/PRESET] switch **10** on the operation panel located at the right side of this unit is set to “PRESET”.
 - You can also use it as a user button by assigning a specific feature in the menu setting to this button.
 (☞ P63 [Adjusting the White Balance])
 (☞ P42 [Assignment of Functions to User Buttons])
- 5** Lens Lock Lever
 (☞ P28 [Attaching the Lens (Supplied)])
- 6** [AUTO FOCUS/11] Autofocus/User 11 Switch
 For switching the Autofocus function ON or OFF. **LENS**
 You can also use it as a user button by assigning a specific feature in the menu setting to this button.
 This switch operates only with the supplied lens.
- 7** [STATUS] Status Screen Display Button
 Press the [STATUS] button to display the status screen on the viewfinder and LCD monitor during normal screen display (when the menu screen is not displayed).
- 8** [CAM/MEDIA] Camera/Media Mode Selection Button
 (☞ P18 [Operation Modes])
- 9** [FULL AUTO ON/OFF] Full Auto Switch
 (☞ P57 [Adjusting the Brightness Automatically])
 (☞ P65 [Automatic White Balance Mode (FAW: Fulltime Auto White balance)])

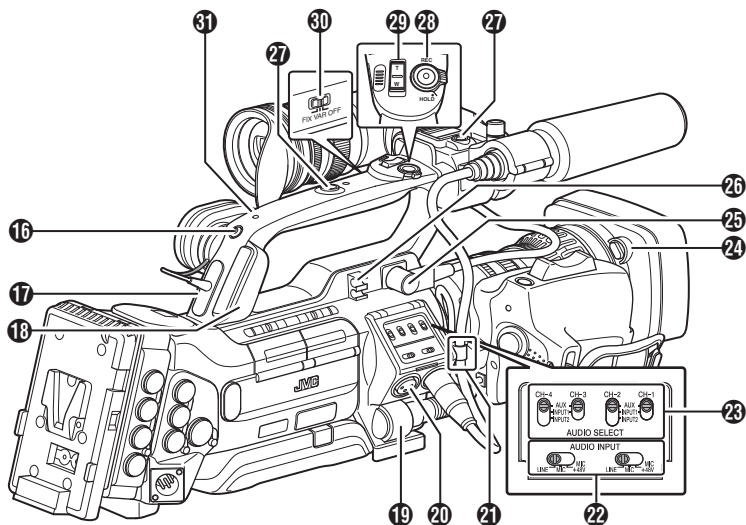

- 10** [MONITOR SELECT] Audio Monitor Selection Switch
(☞ P72 [Audio Output during Recording])
- 11** Monitor Speaker (Cheek Pad)
(☞ P97 [Audio Output during Playback])
- 12** Shoe
For mounting separately sold lights and accessories.
- 13** Microphone Holder Lock Knob
(☞ P28 [Attaching the Microphone (Supplied)])
- 14** Microphone Holder
(☞ P28 [Attaching the Microphone (Supplied)])
- 15** Microphone
(☞ P69 [Audio Recording])
- 16** Back Tally Lamp
(☞ P42 [Tally Lamp])
- 17** [PHONES] Earphone Connection Terminal (Φ3.5)
(☞ P72 [Audio Output during Recording])
- 18** [HOST] USB Host Terminal
For connecting an USB adapter according to the intended purpose when you are connecting the unit to a network.
(☞ P175 [Camera Setup for Network Connection])
- 19** [LENS] Lens Connection Terminal (12-pin Connector)
(☞ P28 [Attaching the Lens (Supplied)])
- 20** [INPUT1/INPUT2] Audio Input Terminal 1, 2 (XLR 3-pin x 2)
(☞ P69 [Audio Recording])
- 21** Lens Cable Clamp
(☞ P28 [Attaching the Lens (Supplied)])
- 22** [AUDIO INPUT] Audio Input Signal Selection Switch 1/2
(☞ P69 [Audio Recording])
- 23** [AUDIO SELECT CH-1~CH-4] Audio Input Signal Selection Switch 1 to 4
(☞ P69 [Audio Recording])
- 24** Hood Release Button
(☞ P29 [Attaching/Detaching the Hood **890** **850**])
- 25** Viewfinder Connection Terminal (20-pin)
(☞ P28 [Attaching the Viewfinder (Supplied)])
- 26** Accessory Cable Clamp
- 27** Accessory Mounting Screw Hole (x2)
- 28** [REC/HOLD] Record Trigger Button/Lock Switch
Starts/stops recording.
Set the switch to [HOLD] to lock the [REC/HOLD] Trigger button. However, note that the other record trigger buttons are not locked.
- 29** Zoom lever at the Handle **LENS**
(☞ P52 [Using the Zoom Lever at the Handle **LENS**])
- 30** [FIX/VAR/OFF] Zoom Speed Switch **LENS**
(☞ P52 [Zoom Operation])
For switching the zoom speed of the zoom lever **29** at the handle.
- 31** Handle

Side Control Panel

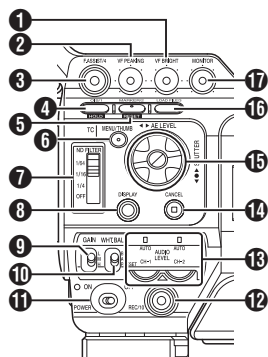

1 [VF BRIGHT] Viewfinder Brightness Adjustment Knob
(☞ P40 [Adjusting the Viewfinder])

2 [VF PEAKING] Outline Adjustment Knob
(☞ P40 [Adjusting the Viewfinder])

Memo : _____

- This knob is disabled when Focus Assist is in operation.
(☞ P55 [Focus Assist Function])

3 [F.ASSIST/4] Focus Assist/User 4 Button
For switching the focus assist function ON or OFF.
(☞ P55 [Focus Assist Function])
You can also use it as a user button by assigning a specific feature in the menu setting to this button.
(☞ P42 [Assignment of Functions to User Buttons])

4 [OIS/1] Optical Image Stabilizer/User 1 Button
For switching the image stabilizer feature mode ON or OFF. **LENS**
You can also use it as a user button by assigning a specific feature in the menu setting to this button.
(☞ P42 [Assignment of Functions to User Buttons])

5 [MARKER/2] Marker/User 2 Button
This button toggles ON/OFF the marker, safety zone, and center mark displays.
You can also use it as a user button by assigning a specific feature in the menu setting to this button.
(☞ P154 [Marker and Safety Zone Displays])
(☞ P42 [Assignment of Functions to User Buttons])

6 [MENU/THUMB] Menu/Thumbnail Button

- Displays the menu screen during Camera mode.
- Switches between [Main Menu] and [Favorites Menu] when the [MENU/THUMB] button is pressed and held down while the menu screen is displayed.
(☞ P103 [Basic Operations in Menu Screen])
- Displays the menu screen when the button is pressed during thumbnail display in the Media mode.
- Stops playback and displays the thumbnail screen when the button is pressed during playback screen display in the Media mode.

7 [ND FILTER] ND Filter Switch
(☞ P62 [Setting the ND Filter])

8 [DISPLAY] Display Button

- Press the [DISPLAY] button to switch to the display screen during normal screen display (when the menu screen is not displayed).
(☞ P36 [Display Screen])
- Switches between [Main Menu] and [Favorites Menu] when the [DISPLAY] button is pressed while the menu screen is displayed.
(☞ P103 [Basic Operations in Menu Screen])

9 [GAIN L/M/H] Gain Level Switch
(☞ P59 [Setting the Gain])

10 [WHT.BAL B/A/PRESET] White Balance Switch
(☞ P63 [Adjusting the White Balance])

11 [POWER ON/OFF] Power ON/OFF Switch and Indicator Lamp
Turns ON/OFF the power. The indicator lamp lights up in green when the power is on. When the power is OFF, "POFF" appears on the LCD monitor and viewfinder.
Wait for 5 seconds or more to turn on the power again.

12 [REC/10] Record Trigger/User 10 Button
Starts/stops recording.
You can also use it as a user button by assigning a specific feature in the menu setting to this button.
(☞ P42 [Assignment of Functions to User Buttons])

13 [AUDIO LEVEL CH-1/CH-2]/[AUTO]CH-1/CH-2 Recording Level Adjustment Knob/Auto Indicator Lamp
(☞ P69 [Audio Recording])

14 [CANCEL] Cancel Button
Cancels various settings and stops playback.

15 Cross-Shaped Button (▲▼◀▶)/Set Button (●)

The function changes according to the operation status of the camera recorder.

■ During menu operation (all modes)

(☞ P103 [Basic Operations in Menu Screen])

Set Button (●) : Confirms menu items and setting values

Cross-shaped Button (▲▼) : Selects menu items and setting values

■ During Camera mode

Shutter operation:

Set Button (●) : Shutter ON/OFF

Cross-shaped Button (▲▼) : Switches shutter speed when shutter is ON

Cross-Shaped Button (◀▶) : AE level operation

Memo : _____

- When [Camera Function] → [AE LEVEL SW] is set to "AE LEVEL/VFR", the cross-shaped button (◀▶) is used to set the number of frames during Variable Frame Rec.

(☞ P93 [Variable Frame Rec])

(☞ P109 [AE LEVEL SW])

16 [LOAD FILE/3] Load File/User 3 Button

Displays the screen for retrieving a picture file. You can also use it as a user button by assigning a specific feature in the menu setting to this button.

(☞ P158 [Loading a Setup File])

(☞ P42 [Assignment of Functions to User Buttons])

17 [MONITOR] Audio Monitor Level Adjustment

Knob

For adjusting the volume of the monitor speaker and earphone.

Viewfinder

(☞ P40 [Adjusting the Viewfinder])

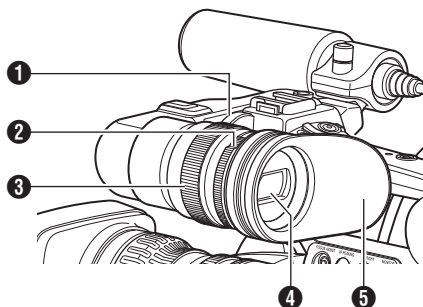

- 1** Viewfinder Slide Lock Ring
For loosening the ring and adjusting the position of the viewfinder **4** to the left or right.
- 2** Eyepiece Focus Ring
For adjusting the visibility.
- 3** Viewfinder Eyepiece Lock Ring
For loosening the ring and adjusting the eyepiece position of the viewfinder to the front or back.
- 4** Viewfinder
- 5** Eyepiece
Prevents external light from entering the viewfinder screen and cameraman's vision.

| LCD Monitor

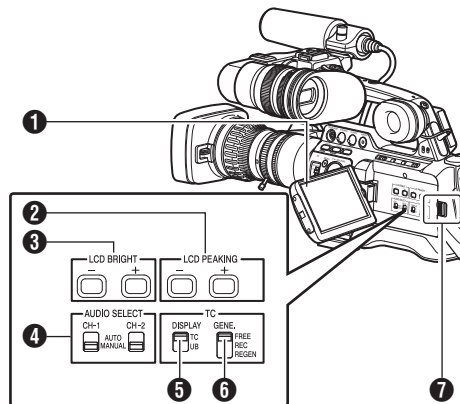

- 1 LCD Monitor
(☞ P38 [Adjusting the LCD Monitor and Viewfinder])
- 2 [LCD PEAKING +/-] LCD Outline Adjustment Button
(☞ P39 [Adjusting the LCD Monitor])
- 3 [LCD BRIGHT +/-] LCD Display Brightness Adjustment Button
(☞ P39 [Adjusting the LCD Monitor])
- 4 [AUDIO SELECT CH-1/CH-2 AUTO/MANUAL] Selection Switch
(☞ P69 [Audio Recording])
- 5 [TC DISPLAY] TC/UB Display Switch
(☞ P72 [Time Code and User's Bit])
(☞ P73 [Setting Time Code Generator])
- 6 [TC GENE.] Time Code Generator Switch
(☞ P72 [Time Code and User's Bit])
(☞ P73 [Setting Time Code Generator])
(☞ P78 [Synchronizing the Time Code with an External Time Code Generator])
- 7 LCD Cover Lock Release Knob

| Side Terminal Section

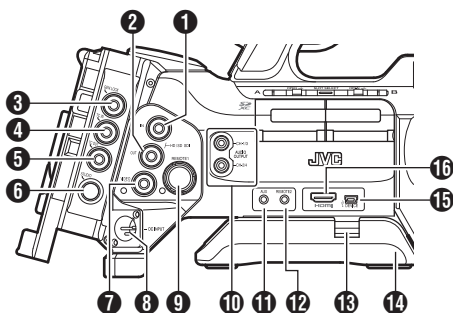

* GY-HM890U/GY-HM890E/GY-HM890CHU/
GY-HM890CHE/GY-HM890RE/GY-
HM890RCHE is used in the illustration here.

- 1 [HD/SD SDI IN] HD/SD SDI Input Terminal (BNC) **890 890CH**
(☞ P168 [Inputting SDI Signals from an External Device **890 890CH**])
- 2 [HD/SD SDI OUT] HD/SD SDI Output Terminal (BNC)
(☞ P125 [SDI Rec Trigger])
(☞ P161 [Connecting External Monitor])
- 3 [GENLOCK] Genlock Terminal (BNC)
(☞ P169 [Inputting External Synchronizing Signals (Genlock)])
- 4 [TC IN] Time Code Input Terminal (BNC)
(☞ P78 [Synchronizing the Time Code with an External Time Code Generator])
- 5 [TC OUT] Time Code Output Terminal (BNC)
(☞ P78 [Synchronizing the Time Code with an External Time Code Generator])
- 6 [STUDIO] Studio Terminal (Mini DIN) **890 890CH**
Connect to this terminal when you are combining the use of devices such as a transmission unit manufactured by a different company.
(☞ P172 [Displaying Return Videos from an External Device **890 890CH**])
- 7 [VIDEO OUT] Video Output Terminal (BNC)
(☞ P78 [Synchronizing the Time Code with an External Time Code Generator])
- 8 [DC INPUT] DC Input Terminal
Input terminal for DC 12 V power supply. Connect it with an AC adapter.
(☞ P30 [Using AC Power (DC IN Power)])
- 9 [REMOTE1] Remote 1 Terminal
(☞ P164 [Connecting a Remote Control Unit])

- 10** [AUDIO OUTPUT CH-1/3, CH-2/4] Audio Output Terminal (RCA)
Output terminal for audio signals.
- Input audio signals are output during Camera mode.
 - Playback audio signals are output during Media mode.
 - In the SDI signal input mode, audio signals superimposed with the SDI input are output.

Memo : _____

- Alarm audio is not output.
- 11** [AUX] AUX Input terminal (Φ3.5 Stereo Mini Jack)
(☞ P69 [Audio Recording])
- 12** [REMOTE2] Remote 2 Terminal
(☞ P164 [Connecting Wired Remote Control])
- 13** Shoulder Pad Slide Button
For adjusting the shoulder pad position. Press this button to adjust the shoulder pad **14** position to the front or back.
- 14** Shoulder Pad
- 15** [DEVICE] USB Mini Terminal
(☞ P160 [Managing/Editing Clips on a PC])
- 16** [HDMI] HDMI Output Terminal
(☞ P161 [Connecting External Monitor])

| SD Slot

(☞ P43 [SD Card])

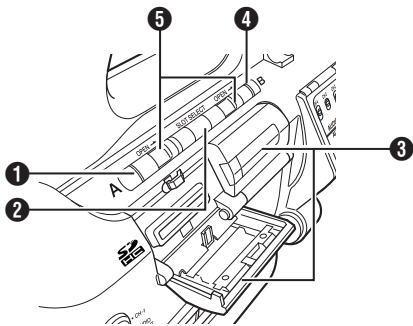

- 1** Card Slot A Status Indicator
- 2** [SLOT SELECT] Card Slot Selection Button
For switching the active card slot during shooting and playback.
- 3** SD Card Cover
- 4** Card Slot B Status Indicator
- 5** [OPEN] SD Card Cover Open/Close Knob

| Rear Terminal

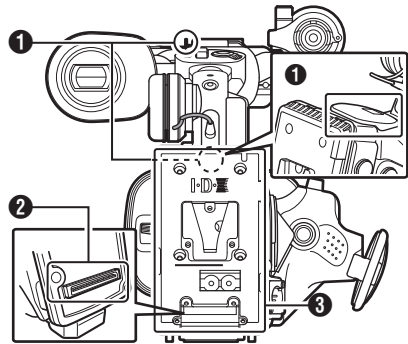

- 1** Shoulder Belt Mount (x2)
For mounting a shoulder belt (sold separately).

Caution : _____

- Be sure to use a shoulder belt with the strength to withstand the weight of this camera recorder.
- If the shoulder belt is not properly attached, the camera recorder may fall and cause injuries.
- Check the instruction manual provided with the shoulder belt before using.

- 2** Accessory Connection Terminal **890 890CH**
Terminal for connecting a KA-M790G (Multicore Remote Adapter: sold separately) or other units.

Memo : _____

- When using this terminal, make sure that the Battery Adapter **3** is removed.

- 3** Battery Loading Folder
The shape varies across the U and E models.
(☞ P31 [Using a Battery Pack])

* The E model is used in the illustration here.

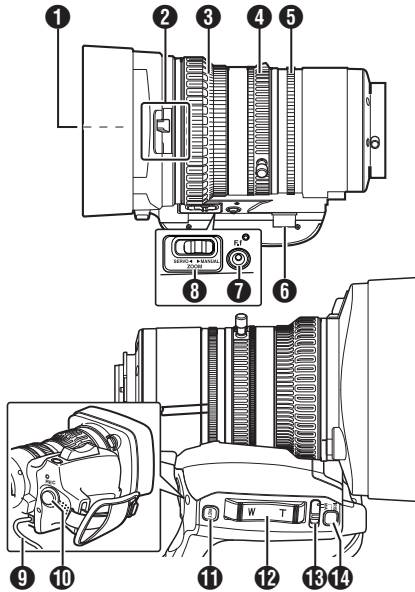

- 1** Filter Built-In Screw
- Transparent or UV filter for lens protection, or filters for various effects can be installed.
 - Installable filter types: Φ 72mmP0.75

Memo : _____

- Remove the lens hood when installing the filter. (☞ P29 [Attaching/Detaching the Hood 890 850])

- 2** Lens Cover Open/Close Switch
(☞ P29 [Opening/Closing the Lens Cover 890 850])
- 3** Focus Ring
(☞ P53 [Focus Operation LENS])
- 4** Zoom Ring
(☞ P52 [Zoom Operation])
To operate zoom with this ring, set the [ZOOM SERVO/MANUAL] switch **8** to "MANUAL".
- 5** Iris Ring
(☞ P58 [Adjusting the Iris])
To operate the auto iris, set the [IRIS A/M] mode switch **13** to "A".

- 6** Zoom Servo Connector
This is a connector for connecting a zoom servo unit (sold separately). When using a separately sold zoom servo unit, set the [ZOOM SERVO/MANUAL] switch **8** to "SERVO".
- 7** [F.f] Back Focus Button and Indicator Lamp
(☞ P41 [Adjusting Back Focus])
- 8** [ZOOM SERVO/MANUAL] Zoom Operation Servo/Manual Switch
Set to "SERVO" in the following cases.
- When using the grip zoom lever **12** on the lens, or the handle zoom lever **29** on this unit
 - When using a zoom servo unit (sold separately)
 - When operating remotely from a remote control unit connected to the [REMOTE1]/[REMOTE2] terminal or from a web browser (☞ P52 [Zoom Operation])
- 9** Lens Cable
For connecting to the camera's [LENS] connection terminal.
- 10** [REC] Record Trigger Button
Starts/stops recording.
- 11** [RET] Return Video Button
Functions as a push autofocus button. **LENS**
(☞ P54 [Setting to Auto Focus Temporarily (Push Auto Focus)])
You can also use it as a user button by assigning a specific feature in the menu setting to this button. (☞ P42 [Assignment of Functions to User Buttons])
- 12** Zoom Lever at the Grip
To operate zoom servo with the zoom lever at the grip, set the [ZOOM SERVO/MANUAL] switch **8** to "SERVO".
(☞ P52 [Using the Zoom Lever at the Grip])
- 13** [IRIS A/M] Iris Mode Switch
Switches the mode of the iris ring **5**. Select "A" to set to auto iris, and "M" to set to manual iris.
- 14** [IRIS] Iris Momentary Button
When the [IRIS A/M] mode switch **13** is set to "M", Auto Iris mode is enabled while the button is pressed down.

Basic System Diagram

Caution :

- VF-HP840U does not function even when it is connected to this camera recorder.

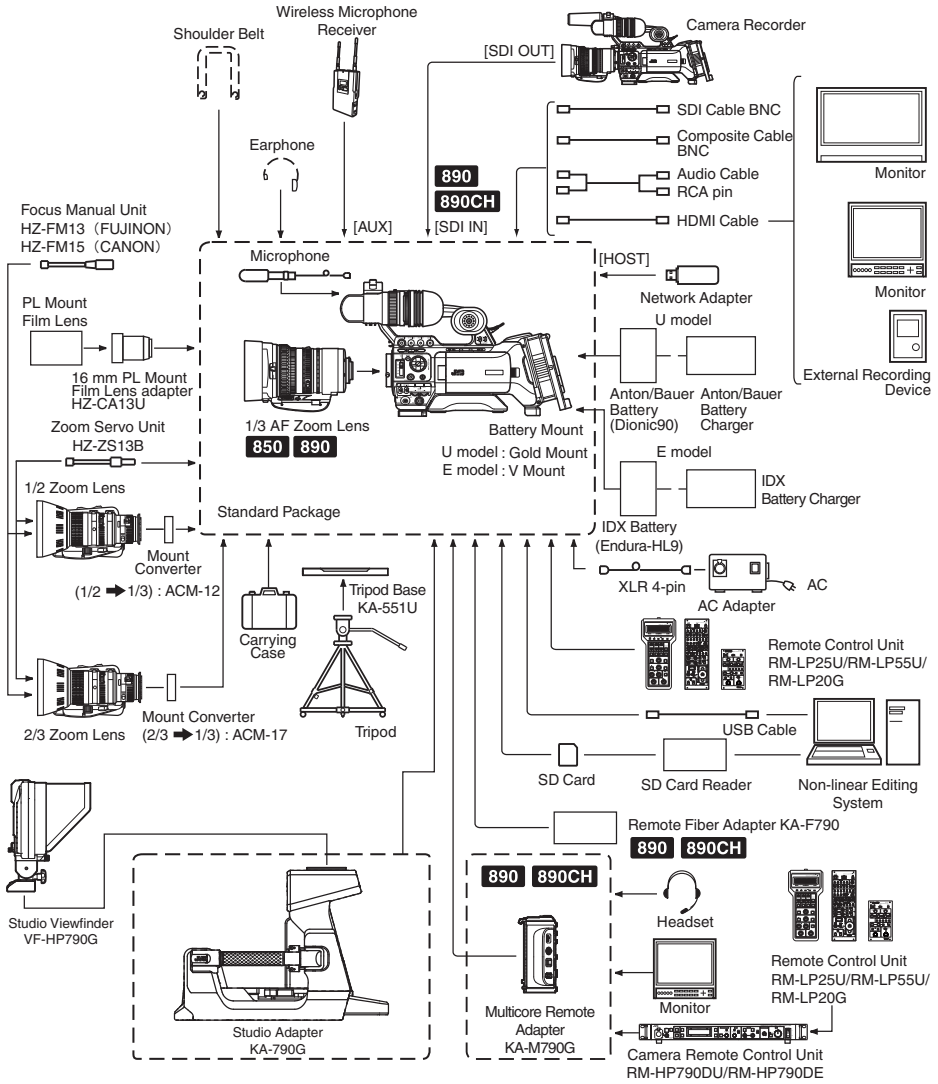

* Models with an E suffix are for the European market and the UL Listing mark is not applicable.

Settings and Adjustments Before Use

Attaching the Lens (Supplied)

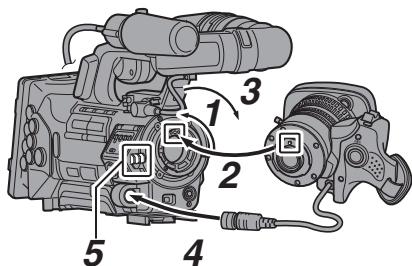

- 1 Loosen the mount ring.
- 2 Attach the zoom lens such that the pin matches the hole of the mounting area.
- 3 Tighten the mount ring.
- 4 Connect the cable connector.
- 5 Attach the lens cable to the clamp.

Memo : _____

- To attach or detach the zoom lens, set the [POWER ON/OFF] switch on this unit to "OFF".
- Tighten the mount ring completely. If it is not fully tightened, the lens may drop or the back focus may be out of alignment.
- Lens is supplied for GY-HM890U, GY-HM890E, GY-HM890RE, GY-HM850U, GY-HM850E and GY-HM850RE.

Adjusting the Grip Belt 890 850

Adjust the grip belt.

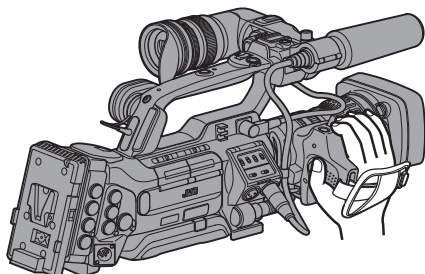

- Caution : _____
- If the grip is loose, the camera recorder may fall off resulting in injuries or malfunction.

Attaching the Microphone (Supplied)

You can attach the supplied microphone to the microphone holder.
The supplied microphone uses a phantom power supply.

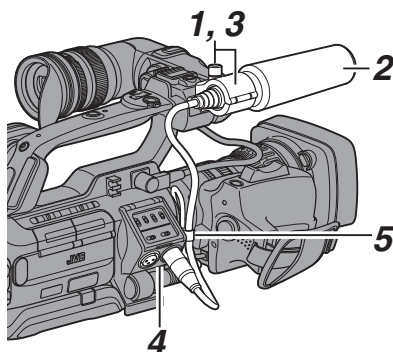

- 1 Turn the knob on the microphone holder counterclockwise to loosen and open the microphone holder.
- 2 Place the microphone in the microphone holder.
- 3 Turn the knob on the microphone holder clockwise to secure the microphone.
- 4 Connect the microphone cable to the [INPUT1] or [INPUT2] terminal.
- 5 Pin the microphone cable to the clamp.
- 6 Perform the settings for the phantom mic correctly.
(P69 [Audio Recording])

Attaching the Viewfinder (Supplied)

- 1 Slide the viewfinder in the direction of the arrow to attach it.
- 2 Turn the slide lock ring to secure the position of the viewfinder.

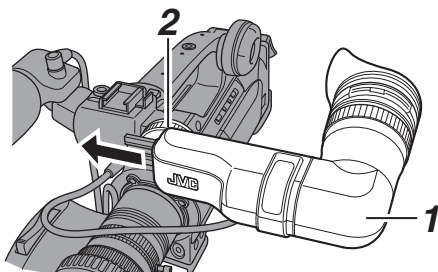

- 3 Attach the viewfinder cable to the viewfinder terminal.
- 4 Pin the viewfinder cable to the clamp.

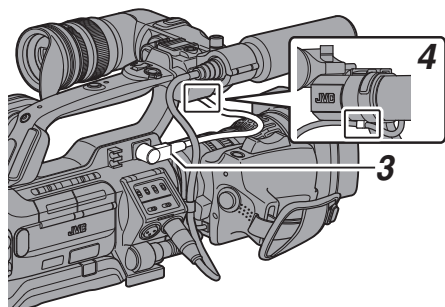

Memo : _____

- To attach or detach the viewfinder, set the [POWER ON/OFF] switch on this unit to "OFF".

Opening/Closing the Lens Cover 890

850

Use the lens cover open/close switch to open or close the lens cover.
Before shooting, open the lens cover.
When this camera recorder is not in use, close the lens cover to protect the lens.

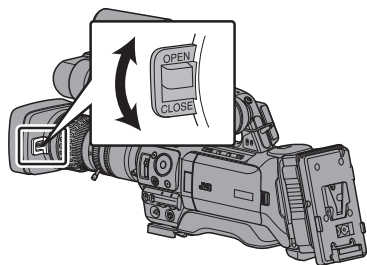

Caution : _____

- Do not press against the lens cover with force. Doing so may damage the lens or the cover.

Attaching/Detaching the Hood 890 850

Attaching the Hood

Align the markings on the camera recorder and hood; turn the hood in the direction of the arrow until it is locked.

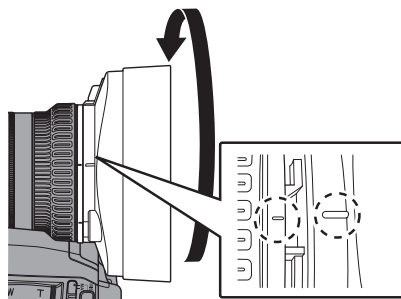

Detaching the Hood

- Remove the hood when attaching a filter, teleconverter or wide converter to the front of the lens.
- While pressing the hood release button, turn the hood in the direction of the arrow (anti-clockwise) to remove it.

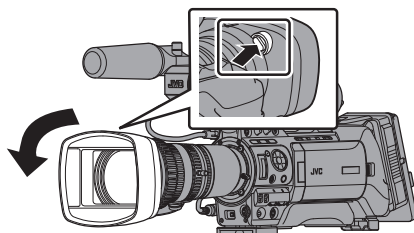

Attaching the Anti-reflective Film

Attach the supplied anti-reflective film onto the LCD monitor if necessary, such as when you are recording in the day or outdoors. Doing so helps to cut down reflection of outside light, thus improving the visibility.

- 1 **Wipe off any dirt, dust or stains on the surface of the LCD monitor.**
- 2 **Peel off the backing of the anti-reflective film halfway.**
Pay attention to prevent fingerprints from being left on the adhesive face.
- 3 **Attaching the Anti-reflective Film**
 - Attach the anti-reflective film by aligning it with the corners of the LCD monitor, while ensuring that there are no air bubbles.
 - Squeeze the air bubbles out.
 - In case if the anti-reflective film is not correctly attached, you can wash and reuse it.

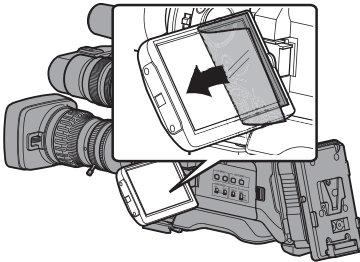

Memo : _____

- Do not press the LCD monitor surface with excessive force when attaching the film.
- For additional orders of the anti-reflective film, please consult the authorized dealer from which this camera recorder was purchased, or our service center.

Anti-reflective film model: LS43131

Power Supply

To use this camera recorder, you can attach a battery pack or connect an AC adapter to it.
 (☞ P31 [Using a Battery Pack])
 (☞ P30 [Using AC Power (DC IN Power)])

- Caution : _____
- Set the [POWER ON/OFF] switch to “OFF” before changing the power supply that operates this camera recorder.

Using AC Power (DC IN Power)

Use the AC adapter (sold separately) to operate the camera recorder with AC power.

- 1 **Connect the DC cable of the AC adapter to the [DC INPUT] terminal of the camera recorder.**
Check that the power of this unit and that of the AC adapter are both set to “OFF”, followed by connecting according to the diagram.

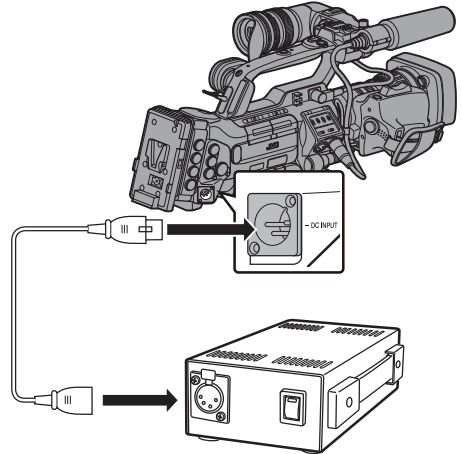

- 2 **Turn on the power of the AC adapter, followed by setting the [POWER ON/OFF] switch of this unit to “ON”.**
Power will be supplied to the camera recorder.

- Caution : _____
- Do not insert or remove the DC cable during recording.
 - Do not use power supply of high voltage fluctuation, containing noise such as ripple, or with insufficient capacity.

Built-In Battery

- The date/time and time code data are stored using the built-in rechargeable battery.
- When power is connected to the camera recorder, the built-in battery always gets recharged. When the power is disconnected, the battery gradually discharges.
- The battery will be totally discharged if left unused for 3 months and the date/time and time code data will be reset. When this happens, set the [POWER ON/OFF] switch to "ON" to display the [Initial Setting] screen, then set the date/time.
(☞ P34 [Initial Settings])

Using a Battery Pack

Recommended Batteries

U model : Dionic90 (Anton/Bauer)

E model : Endura-HL9 (IDX)

- * Models with an E suffix are for the European market and the UL Listing mark is not applicable.

Caution :

- Make use of the recommended batteries. Heavy batteries may fall off if not used correctly.
- For details on how to charge the battery, please refer to the [instruction manual] of the battery in use.

Battery Operating Time

The following are the approximate times for continuous operation on fully-charged batteries.

Battery	Continuous Recording Time (At 25 °C)
Dionic90 (U model)	Approx. 2.8 h
Endura-HL9 (E model)	Approx. 2.7 h

Memo :

- Actual operating times may differ depending on the age of the battery, charging condition, and operating environment.
- Operating time is shortened in cold environment.
- The operating time may shorten when power zoom is used, accessories are connected, or when the LCD monitor is frequently used.

Precautions for the Battery Operation

- Do not remove the battery when the [POWER ON/OFF] switch is "ON".
- Do not insert or remove the DC cable when the battery is in use.
- Leaving the camera recorder unused with the battery inside will deplete the battery power even if you set the [POWER ON/OFF] switch to "OFF". Remove the battery if you are not using the camera recorder.

Attaching/Detaching the Battery (U Model)

Use the Dionic90 (Anton/Bauer) battery.

- 1 **Align the battery guide pins (x3) with the battery adapter guide hole, and insert them directly.**

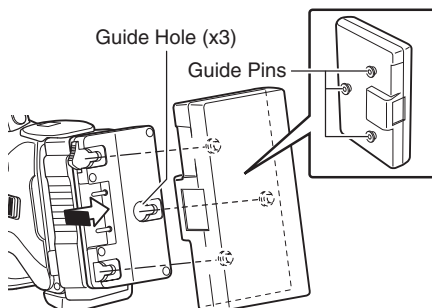

- 2 **Slide the battery in the direction indicated by the arrow until a "click" sound is heard.**

Memo :

- If the guide pins are not inserted straight, the battery will not be attached correctly.

- 3 **Detaching the Battery**

Press down the release lever and slide the battery toward you to detach it from the camera recorder.

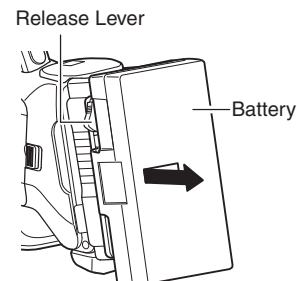

Attaching/Detaching the Battery (E Model)

Use the Endura-HL9 (IDX) battery.

1 Attach the battery.

Face the terminal downward and attach the V mount of the battery onto the V mount attachment bracket of the camera recorder.

2 Press down the battery until it snaps into place.

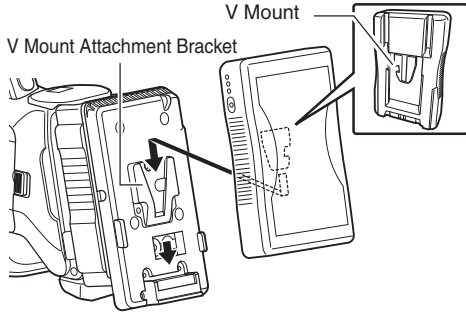

3 Detaching the Battery

Press down the release lever and slide the battery upward to detach it from the camera recorder.

Release Button

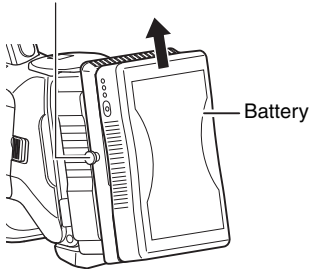

Precautions for Batteries

- Store the battery in a cool and dry place when not in use. Do not expose the battery to high temperatures (such as in a car under direct sunlight). This will cause battery leakage and shorten the battery life.
- Operating time is shortened if the battery terminal is dirty.
- If the operating time shortens drastically even after charging, the battery may be reaching the end of its life. Replace the battery with a new one.

Power Status Display

Viewfinder Screen and LCD Monitor

The power status is indicated on areas such as the display screen and the menu screen. When the value and unit appear in yellow, it is a warning indicating that the supply voltage of the DC power or the remaining battery level is low.

Display	Description
12.0V	Currently powered by a battery.
100min	When the battery power runs out, the battery mark appears hollow, and "RES" (yellow) is displayed.
30%	
RES	
16.0V	
Memo : _____	
<ul style="list-style-type: none"> • You can set the display using [LCD/VF] → [Display Settings] → [Battery]. (☞ P123 [Battery]) 	
	Currently powered by DC power.
	A warning display when the supply voltage of the DC power is low.

Memo : _____

- If the battery in use is not a recommended one, the battery mark which indicates the battery level may not appear.

Display Screen

- (☞ P145 [Display Screen in Camera Mode])
- (☞ P151 [Display Screen in Media Mode])



Menu Screen

- (☞ P104 [Display and Description of the Menu Screen])

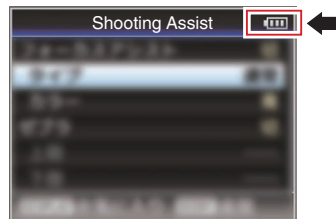

Warnings by Lamp and Warning Tone

Warning status is indicated by tally lamp and warning tone.

- The front and back tally lamps of the camera recorder appear blinking.
- The warning tone is output from the monitor speaker or [PHONES] terminal.

Memo : _____

- If you continue to use the camera recorder while the power warning is displayed, the camera recorder will stop automatically when the battery or supplied voltage from the DC power becomes lower.

Caution : _____

- The remaining battery power and time are displayed as they are from the battery information. Accurate data may not be displayed depending on the battery condition. Replace the battery as soon as possible when the remaining battery power and time are low.

Turning On/Off the Power

Turning On the Power

- 1 Set the [POWER ON/OFF] switch to "ON".
 - The camera recorder starts up in Camera mode and is ready for shooting.
 - The power status indicator lights up in green.

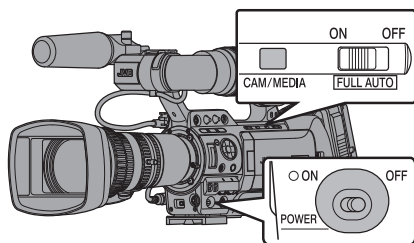

Memo : _____

- The camera recorder always start up in Camera mode when the [POWER ON/OFF] switch is set to "ON".
- Pressing the [CAM/MEDIA] selection button on the camera recorder each time switches the mode.
- Setting [System] → [Record Format] → [System] to "HD(SDI In)" or "SD(SDI In)" switches the camera recorder to the SDI Input mode.

890 890CH

(P18 [Operation Modes])

Camera Mode

Camera images are output on the viewfinder and LCD monitor. If a recordable SD card is inserted, the camera recorder switches to the recording standby mode, and "STBY" is displayed on the operation mode display area of the LCD monitor and viewfinder.

Press the [REC] trigger button to start recording.

Memo : _____

- Playback of SD card is not possible in the Camera mode. However, you can check the most recently recorded video clip using the clip review feature.
(P83 [Viewing Recorded Videos Immediately (Clip Review)])

Media Mode

This mode allows you to play back or delete clips recorded on the SD card.

When a playable SD card is inserted, the thumbnail or playback screen is displayed on the viewfinder and LCD monitor.

USB Mode

- This mode allows you to connect to a PC and transfer the files on an SD card to the PC. (Writing is not allowed)
- When the camera recorder is connected to a USB cable, the message "Change to USB Mode?" appears. Select [Change] and press the Set button to switch to USB mode.
- In USB mode, the camera recorder is recognized by the connected PC as a peripheral drive. (USB mass storage class only) Disable the connection on the PC and remove the USB cable from the camera recorder to switch to Camera mode.
(P160 [Managing/Editing Clips on a PC])

Remote Edit Mode

- This mode enables the list display and editing of the recorded clip data through access to the clip list display page via a web browser on a smartphone, tablet terminal, or PC.
- When you access via a web browser on a smartphone, tablet terminal, or PC, "It is necessary to change the camera mode to "Remote Edit Mode". Change the mode." appears on the web browser. Also, "Change to Remote Edit Mode?" is displayed on the display screen of the camera unit. Selecting [Change] on the camera recorder and pressing the Set button switches to the Remote Edit mode, and enables display of the clip list and editing of the clip metadata. (P184 [Clip Metadata]) (P187 [Uploading a Recording Clip via a Web Browser])

Turning Off the Power

Sets the camera recorder to the recording standby or stop mode.

- 1 Set the [POWER ON/OFF] switch to "OFF".
- 2 Remove the battery and the power to the [DC INPUT] terminal (when not in use for a long time).

Memo : _____

- The [POWER ON/OFF] indicator lamp lights up in green when the camera recorder is shutting down, and turns off when shutdown is complete.

Caution : _____

- Do not set the [POWER ON/OFF] switch to "OFF" during recording. Check that the operation mode display is "STBY" or "STOP" before you turn off the power.
- If you have mistakenly set the [POWER ON/OFF] switch to "OFF" during recording, wait for 5 seconds or more before you turn on the power again.
- When turning off the power, first set the [POWER ON/OFF] switch of the camera recorder to "OFF". Do not remove the battery or turn off the power of the AC adapter while the [POWER ON/OFF] switch is set to "ON".

Initial Settings

When the power is first turned on, the Initial Setting screen for performing the initial settings in the camera recorder appears.

Set the date/time of the built-in clock in the [Initial Setting] screen.

All operations are disabled until initial settings are complete.

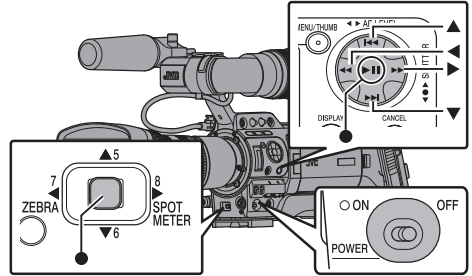

Memo : _____

- It is recommended to use the AC adapter as the power supply.
- Be sure to close the lens cover.

- 1 Set the [POWER ON/OFF] switch to "ON". A language selection screen appears.

- For U models

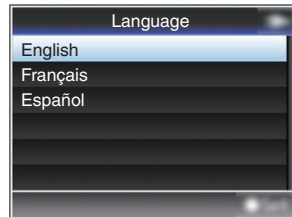

- For E models

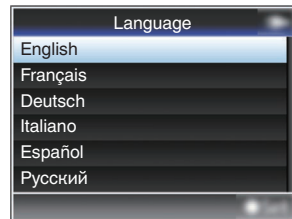

Memo : _____

- The selectable languages vary according to the destination.
- The menus and messages on the screen of the LCD monitor or viewfinder are displayed in the selected language.

- 2 Move the cursor using the cross-shaped button (▲▼) to select a language to use, followed by pressing the Set button (●).
The Initial Setting screen appears.

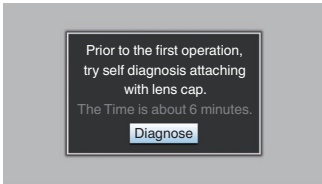

- 3 Ensure that the lens cover is closed, and press the Set button (●).
- Self-diagnosis starts.
 - A progress bar appears, and “Complete Diagnosis” appears when the diagnosis is complete.

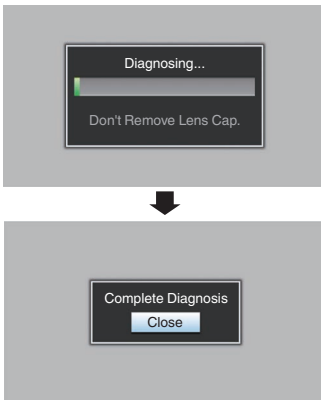

Memo : _____

- It takes about 6 minutes to complete the diagnosis. During the diagnosis, do not operate or turn off the camera recorder.

- 4 Press the Set button (●) after confirming the exit screen.

The [Initial Setting] screen appears.

- For U models

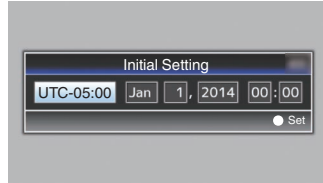

- For E models

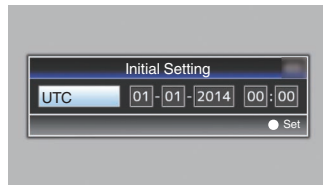

Memo : _____

- The [Initial Setting] screen appears when the power is turned on for the first time and when the power is turned on after the built-in battery is fully discharged.
- The configured date/time data is saved in the built-in rechargeable battery even if the power is turned off.

- 5 Set the time zone and date/time.

- ① Move the cursor with the cross-shaped button (◀▶) and select the setting item.
- ② Change the values with the cross-shaped button (▲▼).

- 6 Press the Set button (●) after setting is complete.

The clock is set to 0 seconds of the input date/time.

Memo : _____

- The configured date/time data can be displayed on the LCD monitor and viewfinder and be recorded to the SD card.
- The value of the year can be set in the range of “2000” to “2099”.

Changing the Time after Initial Setting

Setting the Date/Time

(P131 [Date/Time])

- 1 Select [System] → [Date/Time].

The [Date/Time] screen appears.

- For U models

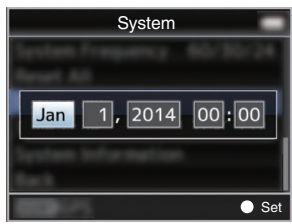

- For E models

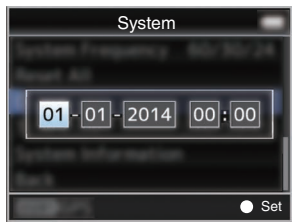

2 Set the date and time.

- ① Move the cursor with the cross-shaped button (◀▶) and select the setting item.
- ② Change the values with the cross-shaped button (▲▼).
- 3 Press the Set button (●) after setting is complete.
The clock is set to 0 seconds of the input date/time.

Changing the Display Style

You can change the display style of the date/time on the menu.

Setting the Date Display (Date Style)

(P124 [Date Style])
The date display can be changed in [LCD/VF] → [Display Settings] → [Date Style].

Setting the Time Display (Time Style)

(P124 [Time Style])
The time display can be changed in [LCD/VF] → [Display Settings] → [Time Style].

Date/Time Display in Each Operation Mode

- During Camera mode:
Date/time of the built-in clock is displayed.
- During Media mode:
Shooting date/time of the clip being played back is displayed.

Displays on the LCD Monitor and Viewfinder

You can display the camera status, media information, zebra pattern, and various markers in the video image on the LCD monitor and viewfinder screen during shooting.

Memo : _____

- When [Main Menu] → [A/V Set] → [Video Set] → [HDMI Out Character]/[SDI Out Character]/[VIDEO Out Character] is set to "On", the display screen and menu screen are also displayed in the video image of the video signal output terminal.
(P126 [HDMI Out Character])
(P126 [SDI Out Character])
(P126 [VIDEO Out Character])

Display Screen

Display Screen (VF/LCD) in Camera Mode

- (P145 [Display Screen in Camera Mode])
- The display switches between three screen types with every press of the [DISPLAY] button. (Display 0 → 1 → 2 → 0)
- Press the [STATUS] button to switch to the status screen.

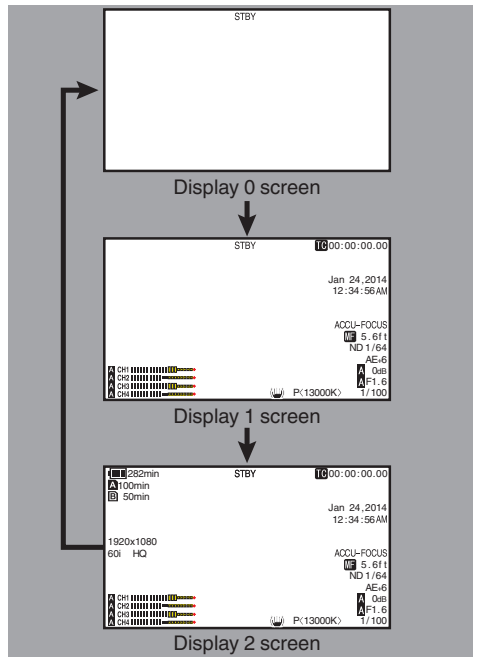

Display Screen (VF/LCD) in Media Mode

(☞ P151 [Display Screen in Media Mode])

- This is the screen display during clip playback in Media Mode.
- The display switches between three screen types with every press of the [DISPLAY] button. (Display 0 → 1 → 2 → 0)

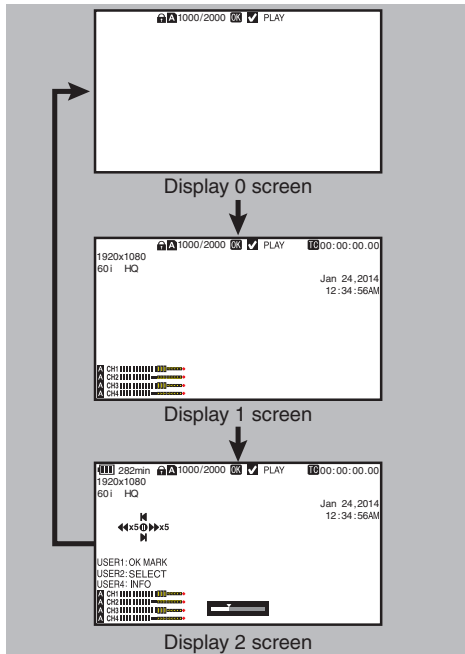

Status Screen

- This screen allows you to check the current settings.
- To display the status screen, press the [STATUS] button in the normal screen.
- The status display differs according to the operation mode (two types). (☞ P18 [Operation Modes])
- Press the [STATUS] button to switch to the display screen.
- Press the [MENU/THUMB] button at each status screen (other than the [Camera] and [Audio Level] screen) to enter the setting screen.
- Use the cross-shaped button (◀▶) to switch screens as follows:

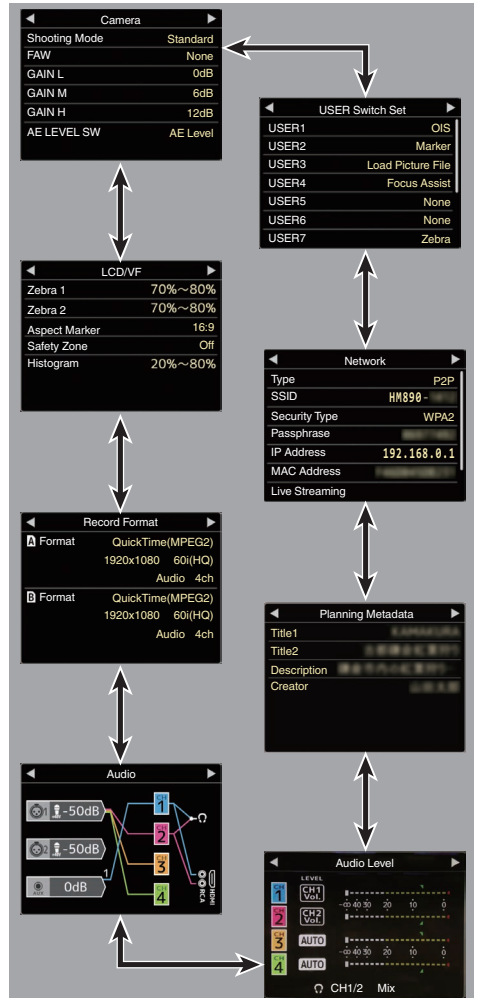

USB Mode Screen

This screen displays the USB mode.



Remote Edit Mode Screen

This mode enables the list display and editing of the recorded clip data through access to the clip list display page via a web browser on a smartphone, tablet terminal, or PC.

(☞ P184 [Clip Metadata])

(☞ P187 [Uploading a Recording Clip via a Web Browser])

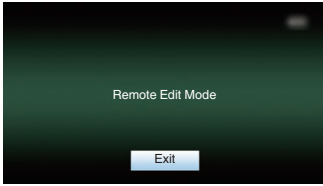

Warning Display

Warning display is displayed in the display screen (Camera mode, Media mode).

(☞ P202 [Error Messages and Actions])

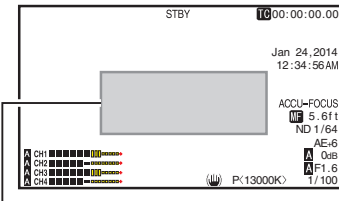

Warning Display Area

Adjusting the LCD Monitor and Viewfinder

You can monitor video images on this camera recorder using the viewfinder, LCD monitor, or both.

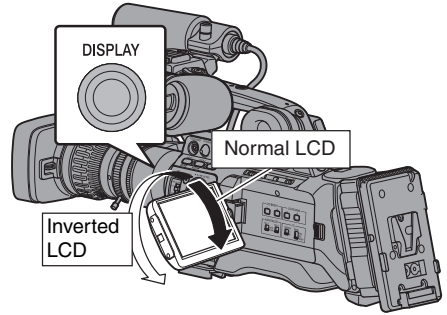

Displays on the LCD Monitor and Viewfinder Screen (VF)

When [LCD/VF] → [LCD + VF] is set to "Off"

(☞ P120 [LCD + VF])

LCD Monitor Status		LCD Display	VF Display
LCD closed	Normal LCD	OFF	ON
	Inverted LCD	ON	OFF *
LCD opened	Normal LCD	ON	OFF *
	Inverted LCD	ON	OFF *

* Turns on when [LCD/VF] → [LCD + VF] is set to "On".

Memo : _____

- Press and hold the [DISPLAY] button for 2 seconds to turn ON/OFF the LCD monitor.
- The function to switch between LCD monitor and viewfinder displays by pressing the [DISPLAY] button can be canceled by opening/closing or rotating the LCD monitor.
- The viewfinder screen is always displayed when [LCD/VF] → [LCD + VF] is set to "On".
- You can display both the LCD monitor and viewfinder screens at the same time by setting [LCD/VF] → [LCD + VF] to "On".

(☞ P120 [LCD + VF])

Adjusting the LCD Monitor

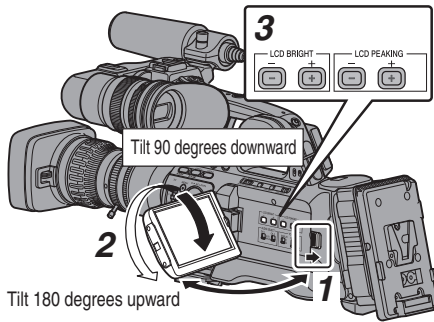

- Slide the LCD cover lock release knob to open the LCD monitor.
- Incline the LCD monitor to a position that enables easy viewing.
 - Rotate the LCD monitor to adjust the angle.
 - While the LCD monitor is open, you can rotate it 180 degrees upward or 90 degrees downward.
 - Rotating the LCD monitor 180 degrees upward enables you to see the screen from the lens side. To display the image when it is viewed from the opposite direction (mirror image), perform setting as follows.
 - Set [Main Menu] → [LCD/VF] → [LCD Mirror] to “Mirror” → Set button (●)
- Adjust the brightness, contour, and contrast of the LCD monitor.

You can change the angle and brightness of the LCD monitor according to your usage condition. Changing the brightness of the screen will not affect the recorded images.

Adjusting the Brightness

Use the [LCD BRIGHT +/-] button to adjust the brightness of the LCD monitor.

- The [+] button brightens the monitor and the [-] button darkens it.
- Press the [+] and [-] buttons simultaneously to return to standard settings.
- During adjustment, the brightness level is displayed on the LCD monitor.



Adjusting the Contour

Use the [LCD PEAKING +/-] button to adjust the contour of the LCD monitor.

- The [+] button increases contour correction and the [-] button decreases contour correction.
- Press the [+] and [-] buttons simultaneously to return to standard settings.
- During adjustment, the contour level is displayed on the LCD monitor.

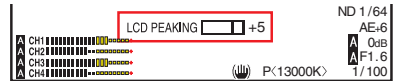

Memo : _____

- During Focus Assist operation, the contour correction effect on the LCD monitor will be temporarily disabled.

Adjusting the Contrast

Use the [LCD Contrast] menu to adjust the contrast of the LCD monitor.

- Adjust using [Main Menu] → [LCD/VF] → [LCD Contrast].
- Increasing the value increases the contrast. [Setting Values: +10 to -10] (Default value: 0)

Adjusting the LCD Backlight

- Adjust using [Main Menu] → [LCD/VF] → [LCD Backlight].

(☞ P120 [LCD Backlight])

- When using the camera recorder at a bright location such as one subject to outside light, setting to “Bright” helps to ease viewing.
- You can also adjust the backlight using the user button assigned with the “LCD Backlight” function.

(☞ P42 [Assignment of Functions to User Buttons])

Adjusting the Viewfinder

You can change the brightness and peaking of the viewfinder screen according to your usage conditions. Changing the brightness of the screen will not affect the recorded images.

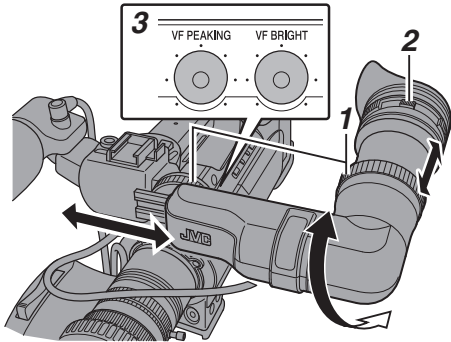

Caution :

- A high-definition viewfinder is used on this camera recorder in order to provide an accurate focusing environment. Due to the characteristic of the display device, colors may appear on the images when you blink your eyes. This is not a malfunction. It does not affect the recorded images, SDI output, VIDEO output, or HDMI output.

- 1 Loosen the two rings, and adjust the position and angle of the viewfinder to one that eases viewing.**
- 2 Turn the visibility adjustment lever to adjust the visibility.**
Turn the visibility adjustment lever to sharpen the image on the viewfinder screen.
- 3 Adjust the brightness, contour, and contrast of the viewfinder screen.**

Adjusting the Brightness

Use the [VF BRIGHT] adjustment knob to adjust the brightness of the viewfinder screen.

Adjusting the Contour

Use the [VF PEAKING] adjustment knob to adjust the outline of the viewfinder screen.

Memo :

- When [Main Menu] → [LCD/VF] → [LCD + VF] is set to “Off”, operate after switching to the viewfinder display by pressing the [DISPLAY] button for 2 seconds or longer.
- During Focus Assist operation, the contour correction effect on the viewfinder will be temporarily disabled.

Adjusting the Contrast

Use the [VF Contrast] menu to adjust the contrast of the viewfinder screen.

- Adjust using [Main Menu] → [LCD/VF] → [VF Contrast].
- Increasing the value increases the contrast. [Setting Values: +10 to -10] (Default value: 0)

Displaying in Black and White

You can display the viewfinder screen in black and white.

- [Main Menu] → [LCD/VF] → [VF Color] item → Press Set button (●) → Select “Off” → Press Set button (●).
(☞ P120 [VF Color])

Adjusting the Monitor Speaker

The monitor speaker can be rotated 180 degrees. Adjust according to the position of your ear.

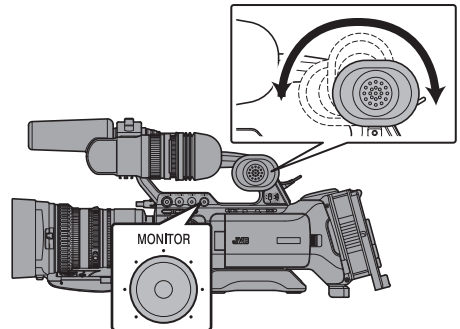

Memo :

- Adjust the volume level of the monitor speaker using the [MONITOR] level adjustment knob on the operation panel located at the right side of the camera recorder. Various warning alarm tones may also be output repeatedly. (☞ P206 [Warning Tone])

Caution :

- The rotation angle of the monitor speaker is 180 degrees. Do not over-rotate the monitor speaker.

Adjusting Back Focus

When the lens is first attached, adjust the back focus of the lens if the focus is not clear when zoomed to the telephoto or wide angle end.

- Place an object 3 m and above away from the camera recorder.
- The Siemens Star Chart is most suitable as the subject.

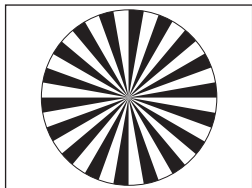

Siemens Star Chart

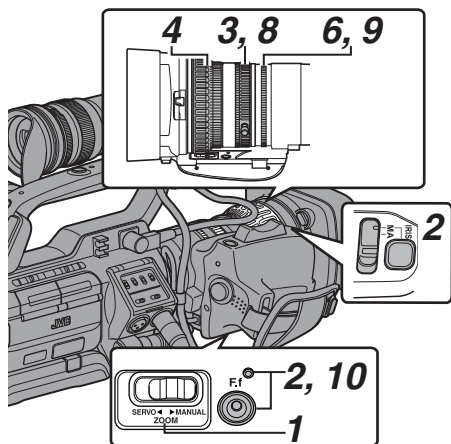

- 1 Set the [ZOOM SERVO/MANUAL] switch to "MANUAL".
- 2 Press and hold down the [IRIS] button, and press the [F.f] back focus button until the indicator lamp lights up (approx. 1.5 seconds).
- 3 Turn the zoom ring to set the lens to the maximum telephoto position.
- 4 Turn the focus ring to adjust the focus of the object.
- 5 Turn the zoom ring to set the lens to the maximum wide angle position.
- 6 Adjust the back focus using the iris ring to set the focus on the subject.
- 7 Repeat steps 3 to 6 a few times until focus is set on both the telephoto and wide-angle ends.
- 8 Turn the zoom ring and check if the image is blurry at the telephoto end at the 20 mm scale mark.
- 9 If blurring occurs, turn the iris ring to adjust the focus. (It is recommended to set the zoom ring near the 40 mm scale mark.)
- 10 Press the [F.f] back focus button until the indicator lamp goes off (approx. 0.5 second).

Memo : _____

- The iris is fixed at the maximum position. Adjust the lighting, shutter and gain to obtain an appropriate video level.

Assignment of Functions to User Buttons

You can assign functions to the following buttons and use them as user buttons. By assigning functions to the buttons, the usability of the camera recorder can be enhanced. Perform settings in the menu items corresponding to each button.

Button	Menu Item
[OIS/1] Button	[USER1]
[MARKER/2] Button	[USER2]
[LOAD FILE/3] Button	[USER3]
[F.ASSIST/4] Button	[USER4]
[▲/5] Button	[USER5]
[▼/6] Button	[USER6]
[7/◀/ZEBRA] Button	[USER7]
[8/▶/SPOT METER] Button	[USER8]
[AWB/9] Button	[USER9]
[REC/10] Button	[USER10]
[AUTO FOCUS/11] Button	[USER11]
[RET] Button	[Lens RET]

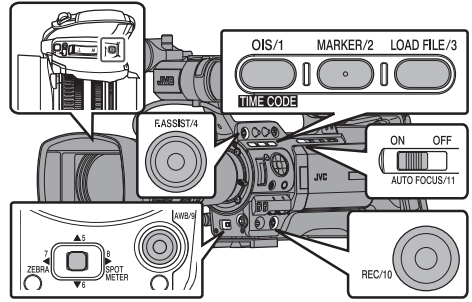

1 Assign functions to the buttons from the menu.
 Set items in [Main Menu] → [Camera Function] → [User Switch Set] → [USER1] to [USER11], and [Lens RET].
 (☞ P111 [User Switch Set Item])

Memo : _____
 • Operations of the user buttons are interlocked with the menu settings.
 • When the menu screen is displayed, these buttons function as the menu operation buttons.
 (☞ P103 [Basic Operations in Menu Screen])

Tally Lamp

This is the indicator lamp for recording and warning. The operation changes according to the menu settings. The lamp blinks when the battery or remaining space on the SD card is low. (Camera mode only)

* Set using [Main Menu] → [System] → [Front Tally]/[Back Tally].
 (☞ P130 [Front Tally/Back Tally])

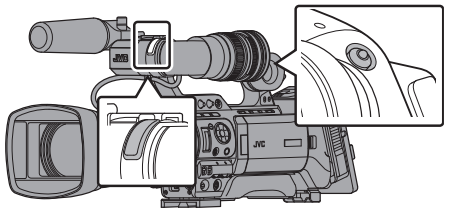

• When [Tally System] is set to "Internal"

Menu Setting	Front Tally/Back Tally			
	Off	Rec	Live Streaming	Rec/Live Streaming
Information on Camera Recorder Functions	Warning	- ▲	▲	▲
	Alarm	- ■	■	■
Camera Recorder Recording Status	Recording	- ●	-	●
	Special Recording in Progress *1	●	-	●
Live Streaming Status	-	-	●	●
Live Streaming in Progress	-	-	●	●

• When [Tally System] is set to "Studio"

Menu Setting	Front Tally/Back Tally	
	Off	On
Information on Camera Recorder Functions	Warning	- ▲
	Alarm	- ■
Input from Remote Control Unit	CALL	- ■ *2
	PROGRAM	- ●
	PREVIEW	- ●

● : Lights up
 ■ : Blinks once in 1 second
 ▲ : Blinks twice in 1 second
 *1 Paused state during special recording ([Clip Continuous]).
 (☞ P89 [Clip Continuous Rec])
 *2 Back tally only

Memo : _____
 • Blinking takes priority over lighting up.

SD Card

This camera recorder saves the recorded images and audio sound on the SD card (sold separately) in the card slot.

Usable Cards

Use a Class 6/10 SD card.

Memo : _____

- Depending on the recording format, SD card with Class 4 or higher performance can also be used.

Some recording formats supports only the use of cards with Class 10 or higher.

(☞ P50 [Selecting a Recording Format])

Caution : _____

- Using cards other than those from Panasonic, TOSHIBA or SanDisk may result in recording failure or data loss.

Estimated Recordable Time of SD Cards

- The estimated recordable time is only a guide. Differences may occur depending on the SD card in use and the battery condition.
- The following is the recording time during audio 4ch recording. However, the duration is for audio 2ch recording in the case of AVCHD. The recording time is longer for 2ch recording.

(☞ P133 [**A** Resolution])

(☞ P134 [**B** Resolution])

(☞ P133 [**A** Frame & Bit Rate])

(☞ P134 [**B** Frame & Bit Rate])

	QuickTime/MP4/MXF		
	MPEG2/HD		
	SP		HQ
	720p	1080i	720p/1080i
4 GB	20	16	12
8 GB	40	32	24
16 GB	80	64	48
32 GB	160	130	96
64 GB (SDXC)	320	260	192
128 GB (SDXC)	640	520	384

(Unit: minute)

	QuickTime				
	H.264/HD		H.264/SD	H.264/Web	
	XHQ	UHQ	-	HQ	LP
	1080i/1080p		480i/576i	960p	480p
4 GB	8	12	40	120	240
8 GB	17	24	80	240	480
16 GB	35	48	160	480	960
32 GB	70	96	320	960	1920
64 GB (SDXC)	140	192	640	1920	3840
128 GB (SDXC)	280	384	1280	3840	7680

(Unit: minute)

	AVCHD				
	HQ	HQ	SP	LP	EP
	1920x1080p	1920x1080i	1440x1080i		
4 GB	16	19	25	46	82
8 GB	33	39	50	95	168
16 GB	67	78	100	190	336
32 GB	135	156	200	380	672
64 GB (SDXC)	270	312	400	760	1344
128 GB (SDXC)	540	632	800	1520	2688

(Unit: minute)

Memo : _____

- If the SD card contains files recorded by devices other than this camera recorder or files that are saved from a PC, the recordable time may be shorter or data may not be properly recorded.
- For each file format, up to 600 clips can be recorded to one SD card on this camera recorder. When 600 clips are recorded to one card, the remaining space is displayed as 0 min regardless of the estimated recordable time, and no further recording can be performed.
- When [Main Menu] → [System] → [Record Set] → [Record Format] → [Format] is set to "AVCHD", up to 4000 clips can be recorded to one SD card.
- When the file format is set to "AVCHD", up to 4000 clips can be recorded to one SD card.

Write-Protect Switch on the SD Card

- Slide the write-protect switch upward to enable writing or deleting.
- Slide the write-protect switch downward to prevent writing or deleting. (Images in the card are protected.)

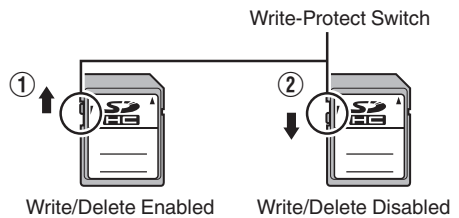

Inserting an SD Card

This camera recorder comes with two card slots (Slot A and B) for video/audio recording and playback.

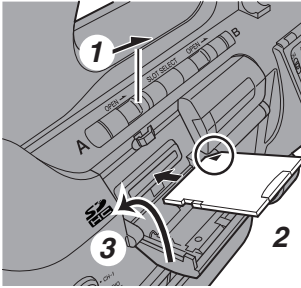

- 1 **Open the SD card cover by sliding the SD card cover knob of the slot to insert the SD card in the direction indicated by the arrow.**
- 2 **Insert an SD card from the end with the notched corner.**
The status indicator of the card slot to which the card was inserted lights up in red.
- 3 **Close the SD card cover.**

Card Slot Status Indicator

The following table shows the respective states of slot A and B.

Lamp	Slot Status
Lights up in red	The inserted SD card is being accessed. (writing/reading data) Do not turn off the power of the camera recorder or remove the SD card.
Lights up in green	On standby. The inserted SD card can be used for recording or playback.
Light goes out	<ul style="list-style-type: none"> • SD card is not inserted. • An unusable card is inserted. • An SD card is inserted but a different slot is selected.

Removing the SD Card

- 1 **Check that the SD card to be removed is not being accessed (status indicator of the card slot lights up in red).**
- 2 **Open the SD card cover by sliding the SD card cover knob of the slot in the direction indicated by the arrow.**
- 3 **Push the SD card and remove it from the slot.**
- 4 **Close the SD card cover.**

Memo : _____

- When both slots are inserted with usable SD cards, the previously selected slot is used.

Caution : _____

- Data may be lost if you turn off the power of the camera recorder or remove the SD card when it is being accessed. All data recorded on the card, including the file that is being accessed, may be corrupted. Be sure to check whether the status indicator is lit in green or turned off before you turn off the power or remove the SD card.
- If you mistakenly remove the card when it is being accessed, reinsert the card only after the status indicator goes off.
- The SD card may not be recognized if you insert and remove the card within a short time. When this happens, remove the card and wait for a few seconds before you reinsert.

Switching the SD cards

When both card slots are inserted with SD cards, you can use the [SLOT SELECT] button to switch the card to use.

When the memory on an SD card is full during recording, data recording automatically switches to the other card.

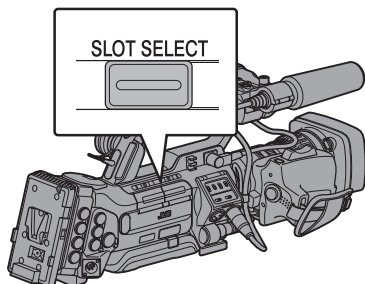

Memo :

- The [SLOT SELECT] button is disabled during recording or playback. Cards will not be switched even if you press the button.

Formatting (Initializing) SD Cards

When the following cards are inserted, [!FORMAT] appears at the remaining media display area. Format the card using the camera recorder menu.

- Unformatted SD cards
- SD cards formatted under different specifications

* For details of the menu operation, refer to “[Basic Operations in Menu Screen] (P 103)”.

Caution :

- Be sure to format the SD card on this camera recorder. SD cards formatted on a PC and other peripheral equipment cannot be used on this camera recorder.
- [!RESTORE] appears at the remaining media display area when an SD card that requires restoring is inserted.

1 Select [System] → [Media] → [Format Media].

(P130 [Format Media])

2 Select the slot of the SD card to be formatted and press the Set button (●).

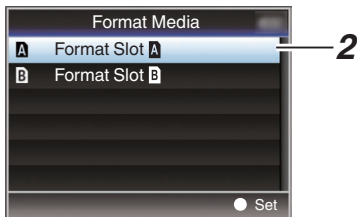

3 The status of the selected SD card appears.

4 Select [Format] and press the Set button (●).

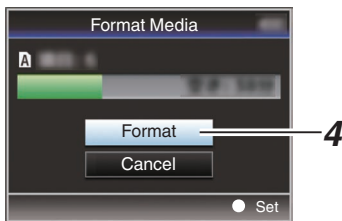

5 Formatting starts.

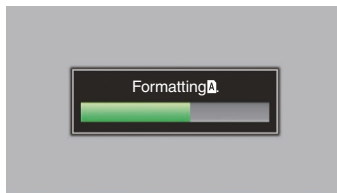

6 Formatting is complete.

When formatting is complete, "Complete" appears and the camera recorder returns to the [Format Media] screen.

Memo : _____

- During formatting, menu operation is unavailable but you can start recording. However, this is only available when a recordable SD card is inserted in the other slot.
- Formatting cannot be performed in the following cases.
 - Recording is in progress on the SD card to be formatted.
 - SD card is not inserted.
 - Write-protect switch of the SD card is set (🔒 is displayed).

Caution : _____

- If you format the SD card, all data recorded on the card, including video data and setup files, will be deleted.

Restoring and Updating the SD Card

It is necessary to restore the SD card if an abnormality occurs to the data in the card due to some reasons.

Memo : _____

- [!RESTORE] appears at the remaining media display area when an SD card that requires restoring is inserted.
- Executing this function while [!RESTORE] is not displayed updates the data inside the SD card.

1 Select [System] → [Media] → [Restore Media].

(P130 [Restore Media])

2 Select the SD card to be restored and press the Set button (●).



3 Restoring starts.

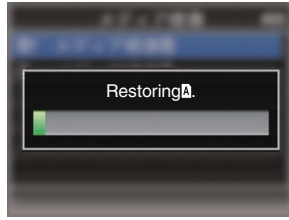

4 Restoring is complete.

- When restoring is complete, "Complete" appears and the camera recorder returns to the [Restore Media] screen.
- When no media that requires restoring is inserted, the camera recorder returns to the [Media] menu screen.

Caution : _____

- [Restore Media] can only be selected in Camera mode. However, it cannot be selected while the camera recorder is recording. Select [Restore Media] in Camera mode when the camera recorder is not recording.
- [Restore Media] does not restore the SD card to its original states completely. If restoring fails, replace or format the SD card. Take note that formatting erases all the information inside the SD card.
- Restoring cannot be performed in the following cases.
 - Camera recorder is recording in progress.
 - SD card is not inserted.
 - Write-protect switch of the SD card is set (🔒 is displayed).

Clips Recorded to SD Cards

Folders in the SD Card

The captured image is recorded into different folders according to the [System] and [A]Format/[B]Format settings.

System	[A]Format/ [B]Format	Record Folder
HD	QuickTime (MPEG2)	DCIM or PRIVATE/JVC/CQAV*
HD	MP4(MPEG2)	PRIVATE/JVC/BPAV
HD/Web	AVCHD	PRIVATE/AVCHD
HD	MXF(MPEG2)	PRIVATE/JVC/CMAV
HD/SD/ Web	QuickTime(H.264)	DCIM or PRIVATE/JVC/CQAVC*

* Select which folder to record to from the menu.
(P136 [Recording in DCIM Folder])

Memo : _____

- By formatting (initializing) the SD card from the [Format Media] menu on the camera recorder, folders required for recording in the current [System] settings will be generated.
- When the [System] settings and [QuickTime(MPEG2)] settings are changed, folders required for recording in those settings will be automatically generated.

Caution : _____

- When a clip inside the folder is moved or deleted using the Explorer (Windows) or Finder (Mac), recording to the SD card may fail if formatting (initializing) of the card is not performed.

Clip (Recorded Data) and Clip Name

- When recording is stopped, the images, audio and accompanying data which are recorded from start to stop are recorded as one "clip" on the SD card.
- An 8-character clip name is automatically generated for the recorded clip.
("Clip Name Prefix" + "Clip Number")
- When [Main Menu] → [System] → [Record Set] → [Record Format] → [A]Format is set to "AVCHD", the clip name generated consists of only the Clip Number (5-digit number).
(P133 [A]Format)]

Example: In the case of QuickTime/MP4/MXF

ABCG0001

Clip Number

A number in automatic ascending order is assigned in the recording order.

The Clip Number can be reset in the menu.*

Clip Name Prefix (any four alphanumeric characters)

This is set to "xxxG" ("xxx" denotes the last 3 digits of the serial number) by default.

* [Clip Set] → [Reset Clip Number]
(P137 [Reset Clip Number])

Memo : _____

- Before recording starts, you can set any characters for the clip name prefix by using [Main Menu] → [System] → [Record Set] → [Clip Set] → [Clip Name Prefix].
(P137 [Clip Name Prefix])
- Changes cannot be made after recording.

Recorded Clips

- The recorded materials may be split into several files but they can be played back continuously on the camera recorder.
- Clips may be recorded across the two SD cards in card slots A and B depending on the recording time of the clip.
- When copying videos in MP4 file format to a HDD using a PC, it is recommended to use [JVC ProHD Clip Manager Software], which is found in the supplied disc, to maintain continuity.

Caution : _____

- A clip recorded across several cards cannot be played back continuously. Continuous playback is only possible when the recording is made on one card.

About the Operation Lock Feature

You can use this feature to prevent erroneous camera operation.

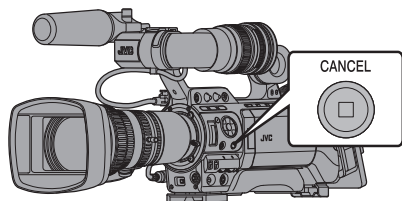

1 While in the Camera mode (when the display screen appears), press and hold the [CANCEL] button for 5 seconds or longer.

- The operation lock turns on, and an operation lock icon (🔒) appears on the display screen.

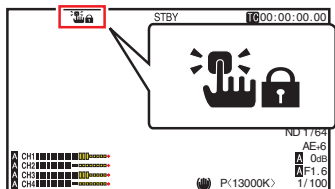

- Press the [CANCEL] button again for 5 seconds or longer to turn off the operation lock.

Memo : _____

- The operation lock feature is only valid in the Camera mode.
(🔑 P18 [Operation Modes])
- The power turns off and the operation lock is disengaged.
- The following remote operations are possible even when the operation lock feature is turned on.
 - Operation from the wired remote control connected to the [REMOTE2] terminal or the remote control unit connected to the [REMOTE1] terminal.
 - Remote operation of the camera through access via a web browser on devices such as a smartphone, tablet terminal, or PC.

Operation lock does not apply to the following buttons and switches.

- [POWER ON/OFF] switch
- [ND FILTER] switch
- [AUDIO SELECT CH-1~CH-4] input selection switch
- [AUDIO INPUT] selection switch 1/2
- All switches inside the LCD monitor door
- All switches on the lens ([REC] button, [RET] button, back focus button, [IRIS A/M] switch, [IRIS] button, grip zoom lever, [ZOOM SERVO/MANUAL] switch, zoom ring, iris ring, focus ring)
- [MONITOR] adjustment knob
- Grip zoom lever/handle zoom lever
- [ZOOM SERVO/MANUAL] switch
- [FIX/VAR/OFF] zoom speed switch
- [REC/10] button (side operation panel)
- [AWB/9] button (lens bottom)
- [REC] button (handle top)

Memo : _____

- Operation lock is not applied only when “Rec” is assigned to the [AWB/9] button at the bottom of the lens or the [REC/10] button on the side operation panel in the [Camera Function] → [User Switch Set] menu.

Basic Shooting Procedures

Preparations

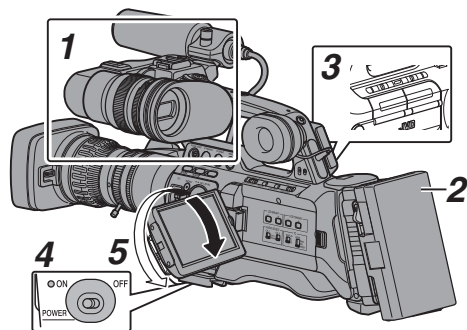

- 1 Attach the necessary accessories.**
(☞ P28 [Settings and Adjustments Before Use])
- 2 Supply battery or AC adapter power to the camera recorder.**
(☞ P30 [Power Supply])
- 3 Insert an SD card.**
(☞ P43 [SD Card])
- 4 Turn on the power of the camera recorder.**
Setting the [POWER ON/OFF] switch to “ON” starts up the camera recorder in the Camera mode to enable shooting.
- 5 Adjust the angle of the LCD monitor and viewfinder.**
(☞ P38 [Adjusting the LCD Monitor and Viewfinder])

Shooting

- 1 Configure the video and audio input settings.**
You have to configure video settings such as brightness adjustment (iris, gain, shutter) and white balance adjustment in order to start shooting. You also have to adjust the audio input settings and audio recording level for audio recording.
 - Adjusting the Brightness
(☞ P57 [Adjusting the Brightness])
 - Adjusting the White Balance
(☞ P63 [Adjusting the White Balance])
 - Adjusting Audio Input Settings and Recording Level
(☞ P69 [Audio Recording])

- 2 Press the [REC] button to start recording to the SD card.**

This camera recorder has three [REC] buttons. Any of the [REC] buttons can be used to start/stop recording by default.

The front and back tally lamps light up in red during recording.

- Zoom Operation
(☞ P52 [Zoom Operation])
- Adjusting the Focus Manually
(☞ P53 [Focus Operation **LENS**])

Memo : _____

- If both the slots are loaded with recordable cards in the factory default, pressing the [REC] button starts recording only to the media in the selected slot.
When [Main Menu] → [System] → [Record Set] → [Slot Mode] is set to “Dual”, recording can be performed simultaneously to the cards in both the slots.
(☞ P85 [Dual Rec])
- The tally lamps can be turned off in the [System] → [Front Tally]/[Back Tally] menu.
(☞ P130 [Front Tally/Back Tally])

- 3 Check the most recently captured images.**

- Press the user button assigned with the [Clip Review] function to activate the Clip Review function. The most recently captured images are played back on the LCD monitor and viewfinder screen.
- After playback, the camera recorder returns to standby mode (STBY).
(☞ P83 [Viewing Recorded Videos Immediately (Clip Review)])

Selecting a Recording Format

The following are steps to select the video resolution, recording/playback file format, and video format of videos recorded on this camera recorder.

Selecting a Recording Format

1 Set the [System Frequency].

Select using [Main Menu] → [System] → [System Frequency].
(☞ P131 [System Frequency])

2 Select a recording format.

Set the following items in [Main Menu] → [Record Format].

- Slot A settings
 - Recording file format
(☞ P133 [A Format])
 - Recording resolution
(☞ P133 [A Resolution])
 - Number of recording frame/image quality
(☞ P133 [A Frame & Bit Rate])
 - Number of recording audio channels
(☞ P133 [A Audio])
- Slot B settings (as needed)
 - (☞ P134 [B Format])
 - (☞ P134 [B Resolution])
 - (☞ P134 [B Frame & Bit Rate])
 - (☞ P134 [B Audio])

3 Select an aspect ratio for the SD video recording (as needed).

Select an SD video aspect ratio when [System] is set to “SD”, “HD+SD” or “SD(SDI In)”.

You can select “16:9” or “4:3”.

(☞ P135 [SD Aspect])

Memo : _____

- The aspect ratio is fixed at “16:9” when [System] is set to “HD” “HD+Web” or “HD(SDI In)”.

4 After setting is complete for all items, press the [OIS/1] button.

- The recording format is switched.
- A “Please Wait...” message appears on the screen during switching.

Possible Slot A Setting Combinations

When [System] → [System Frequency] is set to “60/30/24”

- When [Record Format] → [System] is set to HD, “HD+SD”, “HD+Web”, “HD(SDI In)” (U model)
- When [Record Format] → [System] is set to HD, “HD+Web”, “HD(SDI In)” (E model)

Record Format			
A Format	A Resolution	A Frame & Bit Rate	A Audio
QuickTime MP4 MXF *1 (MPEG2)	1920x1080	60i (HQ)	4ch/ 2ch
		30p (HQ) *2	
		24p (HQ) *2	
	1440x1080	60i (HQ)	
		60i (SP)	
		1280x720	
AVCHD	1920x1080	30p (HQ) *2	2ch
		60i (HQ)	
		60i (SP)	
	1440x1080	60i (LP)	
		60i (EP)	
		QuickTime (H.264)	
60i (XHQ)			
30p (XHQ) *2			
24p (XHQ) *2			
60i (UHQ)			
30p (UHQ) *2			
24p (UHQ) *2			

*1 The “1280x720” setting is not available for MXF files.

*2 Not selectable in the “HD(SDI In)” setting.

- When [Record Format] → [System] is set to “SD”, “SD(SDI In)” (U model)

Record Format			
A Format	A Resolution	A Frame & Bit Rate	A Audio
QuickTime (H.264)	720x480	60i	4ch/ 2ch

When [System] → [System Frequency] is set to “50/25”

- When [Record Format] → [System] is set to HD, “HD+Web”, “HD(SDI In)” (U model)
- When [Record Format] → [System] is set to HD, “HD+SD”, “HD+Web”, “HD(SDI In)” (E model)

Record Format			
A Format	A Resolution	A Frame & Bit Rate	A Audio
QuickTime MP4 MXF *1 (MPEG2)	1920x1080	50i (HQ) 25p (HQ) *2	4ch/ 2ch
	1440x1080	50i (HQ)	
		50i (SP)	
		1280x720	
AVCHD	1920x1080	50p (HQ) *2	2ch
		50i (HQ)	
		50i (SP)	
	1440x1080	50i (LP) 50i (EP)	
QuickTime (H.264)	1920x1080	50p (XHQ) *2	4ch/ 2ch
		50i (XHQ)	
		25p (XHQ) *2	
		50i (UHQ)	
		25p (UHQ) *2	

*1 The “1280x720” setting is not available for MXF files.

*2 Not selectable in the “HD(SDI In)” setting.

- When [Record Format] → [System] is set to “SD”, “SD(SDI In)” (E model)

Record Format			
A Format	A Resolution	A Frame & Bit Rate	A Audio
QuickTime (H.264)	720x576	50i	4ch/ 2ch

Possible Slot B Setting Combinations

When [System] → [System Frequency] is set to “60/30/24”

- When [Record Format] → [System] is set to “HD +SD” (U model)

Record Format			
B Format	B Resolution	B Frame & Bit Rate	B Audio
QuickTime (H.264)	720x480	60i	4ch/ 2ch

- When [Record Format] → [System] is set to “HD +Web”

Record Format			
B Format	B Resolution	B Frame & Bit Rate	B Audio
QuickTime (H.264)	480x270	30p (LP) 24p (LP)	4ch/ 2ch
	960x540	30p (HQ) 24p (HQ)	
AVCHD	1440x1080	60i (LP) 60i (EP)	2ch

When [System] → [System Frequency] is set to “50/25”

- When [Record Format] → [System] is set to “HD +SD” (E model)

Record Format			
B Format	B Resolution	B Frame & Bit Rate	B Audio
QuickTime (H.264)	720x576	50i	4ch/ 2ch

- When [Record Format] → [System] is set to “HD +Web”

Record Format			
B Format	B Resolution	B Frame & Bit Rate	B Audio
QuickTime (H.264)	480x270	25p (LP)	4ch/ 2ch
	960x540	25p (HQ)	
AVCHD	1440x1080	50i (LP)	2ch
		50i (EP)	

Zoom Operation

Adjusts the angle of view.

Zoom ratio: 1x to 20x (optical zoom only)

Zooming can be operated using any of the three levers/rings below.

- Zoom Lever at the Grip
- Zoom Lever at the Handle **LENS**
- Zoom Ring at the Lens Section:
Functions as a zoom ring when the [ZOOM SERVO/MANUAL] switch is set to "MANUAL".

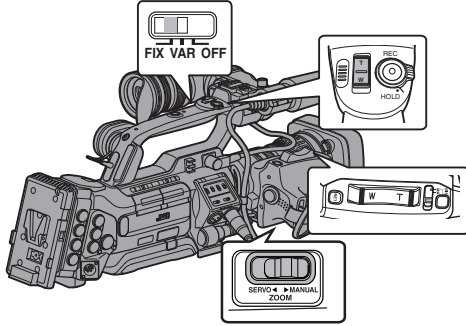

Using the Zoom Lever at the Grip

- 1 Set the [ZOOM SERVO/MANUAL] switch to "SERVO".
- 2 Press the zoom lever to zoom.
 - The zoom speed changes according to the extent the zoom lever is being pushed.
 - Zooms into wide angle and increases the angle of view when "W" is pressed.
 - Zooms into telephoto and decreases the angle of view when "T" is pressed.
 - A zoom bar appears during zoom operation

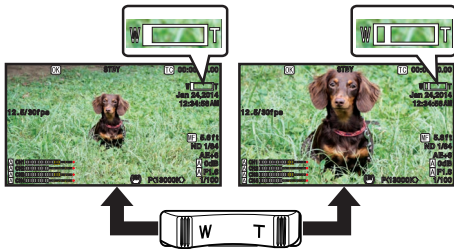

Using Zoom Ring at the Lens Section

- 1 Set the [ZOOM SERVO/MANUAL] switch to "MANUAL".

You can adjust the preferred angle of view by turning the zoom ring.

Using the Zoom Lever at the Handle

The handle zoom lever operates only when the supplied lens is in use.

- 1 Set the [ZOOM SERVO/MANUAL] switch to "SERVO".
- 2 Set the [FIX/VAR/OFF] zoom speed switch to "FIX" or "VAR".

Memo :

- Setting to "FIX" will allow the zoom operation to move at the speed set in [Handle Zoom Speed].
 - Set the zoom speed using [Main Menu] → [Camera Function] → [Handle Zoom Speed]. (P110 [Handle Zoom Speed **LENS**])
- Setting to "VAR" will change the zoom speed according to the pressure applied on the lever.

- 3 Press the zoom lever at the handle to zoom.

Memo :

- When the [FIX/VAR/OFF] zoom speed switch is set to "OFF", the zoom lever at the handle section cannot be used.

Saving/Recalling Current Zoom Position (Preset Zoom) **LENS**

The handle zoom lever operates only when the supplied lens is in use.

This allows you to register up to three zoom positions.

Focus Operation **LENS**

1 Assign the “Preset Zoom1”, “Preset Zoom2”, or “Preset Zoom3” function to any of the user buttons.

* This excludes the [AUTO FOCUS/11] button.

(☞ P42 [Assignment of Functions to User Buttons])

(☞ P111 [USER1 to USER11, Lens RET])

2 Save the current zoom position.

- Press any of the buttons assigned with the “Preset Zoom1”, “Preset Zoom2”, or “Preset Zoom3” function for more than 1 second.
- The current zoom position will be stored.

3 Recall the stored zoom position.

- Press any of the buttons assigned with the “Preset Zoom1”, “Preset Zoom2”, or “Preset Zoom3” function and release within 1 second.
- The camera recorder zooms to the stored zoom position.

Memo : _____

- To recall the stored zoom position, set the [ZOOM SERVO/MANUAL] switch to “SERVO”.
- The speed to zoom to the zoom position can be set with [Main Menu] → [Camera Function] → [Preset Zoom Speed].
(☞ P112 [Preset Zoom Speed **LENS**])
- Operating other zoom maneuvers during a zoom position recall will cancel the recall.

| Adjusting Focus Manually

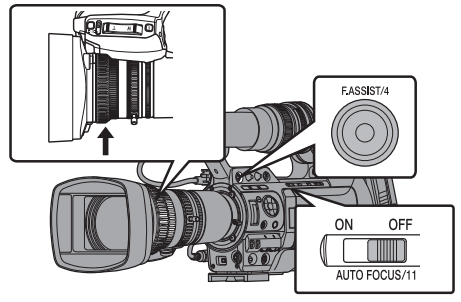

1 Set the [AUTO FOCUS/11] switch to “OFF”.

The manual focus icon **MF** appears on the screen.

The handle zoom lever operates only when the supplied lens is in use.

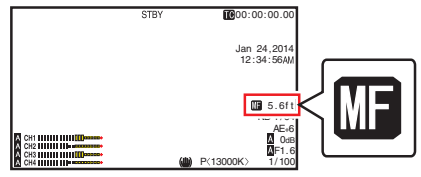

Memo : _____

- If [Main Menu] → [LCD/VF] → [Display Settings] → [Focus] is set to “Off”, the **MF** icon will not appear.
(☞ P122 [Focus **LENS**])

2 Turn the focus ring to adjust the focus.

Memo : _____

- Using the Focus Assist or Expanded Focus function makes it easier to focus.
(☞ P55 [Focus Assist Function])
(☞ P55 [Expanded Focus Function])
- Even while in the Manual Focus mode, pressing the [RET] button on the lens or the user button assigned with the “One Push Focus” function switches the camera recorder to the One-push Autofocus mode.

- Even while in the Manual Focus mode, pressing and holding the [RET] button on the lens or the user button assigned with the “One Push Focus” function switches the camera recorder to the Push Autofocus mode.
(☞ P54 [One Push Auto Focus])
(☞ P54 [Setting to Auto Focus Temporarily (Push Auto Focus)])

Adjusting Focus Automatically **LENS**

The handle zoom lever operates only when the supplied lens is in use.
Set the [AUTO FOCUS/11] switch to “ON”.
The auto focus icon **AF** appears on the screen.

Memo : _____

- If [Main Menu] → [Camera Function] → [AF Assist] is set to “Area” or “Far/Near”, you can turn the focus ring to shift the auto focus point while in the automatic focus adjustment mode.
(☞ P54 [AF Assist Function **LENS**])
(☞ P110 [AF Assist **LENS**])
- If [Main Menu] → [LCD/VF] → [Display Settings] → [Focus] is set to “Off”, the auto focus will not appear.
(☞ P122 [Focus **LENS**])

One Push Auto Focus

While in the Manual Focus mode, pressing the [RET] button on the lens (less than 1 second) sets the focus at the center of the frame automatically.

Memo : _____

- Face detection does not work during One Push Auto Focus.
- AF Assist does not function.
- When the operation is complete, the camera recorder returns to the Manual Focus mode automatically.
- One Push Auto Focus functions with emphasis on the focusing speed. This function is not suitable during recording.
- “One Push Focus” is assigned to the [RET] button on the lens in the factory default setting.
- “One Push Focus” can also be assigned to other user buttons.
(☞ P42 [Assignment of Functions to User Buttons])

Setting to Auto Focus Temporarily (Push Auto Focus)

- In the Manual Focus mode, the camera recorder switches temporarily to the Autofocus mode and automatically adjusts the focus when you take a shot with the [RET] button on the lens pressed down.
- Release the [RET] button to return to the Manual Focus mode.

Memo : _____

- Face detection does not work during Push Auto Focus.
- “One Push Focus” is assigned to the [RET] button on the lens in the factory default setting.
- “One Push Focus” can also be assigned to other user buttons.
(☞ P42 [Assignment of Functions to User Buttons])

AF Assist Function **LENS**

To shift the auto focus point during Auto Focus (AF), you can turn the focus ring to set the point to the left, center, right, or near and far directions.

- Set [Main Menu] → [Camera Function] → [AF Assist].
 - Area:
 - Selecting this option displays the **AF** icon in the area.
 - Turning the focus ring during AF displays the focus area on the left, center, and right side for about 2 seconds. Turning the focus ring within 2 seconds allows you to move the orange frame to select the focus area. After selecting the area, focus is automatically adjusted to a focus point near the selected area.

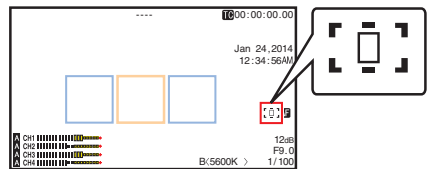

- * The icons (**AF**, **FN**, and **FO**) change in conjunction with the orange frame in the focus area.

Memo : _____

- When [Face Detect] is set, “Area” is not selectable.

- **Far/Near:**
This option allows you to shift the auto focus point to near and far directions by turning the focus ring during AF.
Focus is automatically adjusted to a focus point near the position where the focus ring stops turning.

Focus Assist Function

- When the [F.ASSIST/4] button is pressed during shooting, the focused area is displayed in color. This enables easy and accurate focusing.
- Select the color (blue, red or green) in the menu.

- Memo : _____
- When [Main Menu] → [LCD/VF] → [Shooting Assist] → [Focus Assist] → [Type] is set to “ACCU-Focus”, the depth of field becomes shallower to enable easier focusing.
(☞ P121 [Focus Assist])
 - The “ACCU-Focus” function switches automatically to “Off” after about 10 seconds.
 - Select the display color in [Main Menu] → [LCD/VF] → [Shooting Assist] → [Focus Assist] → [Color].
(☞ P121 [Color])
 - If you use the zebra function and the Focus Assist function at the same time, it may be difficult to see the effect of the Focus Assist. In this case, turn off the zebra function.
(☞ P79 [Setting Zebra Pattern])
 - During Focus Assist operation, the contour correction effect on the viewfinder/LCD monitor will be temporarily disabled.

Setting Focus Assist Function to a User Button

- You can assign the “Focus Assist” function to a user button.
(☞ P42 [Assignment of Functions to User Buttons])

Expanded Focus Function

Magnifies the image at the center. Doing so enables precise focus to be established easily.

1 Assign the “Expanded Focus” function to any of the user buttons.

- * This excludes the [AUTO FOCUS/11] button.
(☞ P42 [Assignment of Functions to User Buttons])
(☞ P111 [USER1 to USER11, Lens RET])

2 Press the user button that is assigned with the “Expanded Focus” function.

- [EXPANDED] (yellow color) appears on the screen, and the center part of the image is enlarged.
- Pressing the user button again restores the image to the original size.

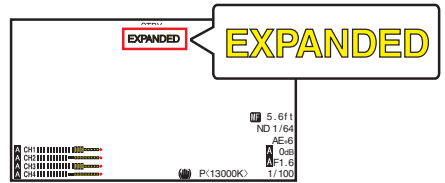

- Memo : _____
- To set the operation when the button is pressed, go to [Main Menu] → [Camera Function] → [User Switch Set] → [Expanded Focus].
(☞ P112 [Expanded Focus])
 - This function can be used together with the Focus Assist function.
 - The magnification ratio varies with the format of the record signals.
 - Magnifying an image does not alter the size of the recorded image.
 - This function is unavailable when [Main Menu] → [System] → [Record Set] → [Record Format] → [System] is set to “SD”, “HD(SDI In)”, or “SD(SDI In)”.

Adjusting the Focus by Face Detection **LENS**

This function detects human faces and automatically adjusts focus during Auto Focus. It can also track moving objects. When several faces are detected, you can select one to focus on.

- Memo : _____
- This function can also adjust the brightness automatically according to the brightness of the face detected.
(☞ P112 [Face Detect **LENS**])

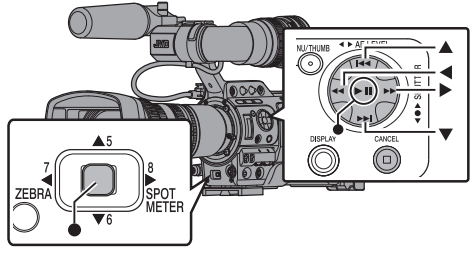

1 Assign the “Face Detect” function to any of the user buttons.

* This excludes the [AUTO FOCUS/11] button.
(☞ P42 [Assignment of Functions to User Buttons])

2 Focus the camera recorder on a person and press the user button that is assigned with “Face Detect”.

- When Face detection is enabled, the face detection icon (👤) appears.
 - When [Main Menu] → [Camera Function] → [User Switch Set] → [Face Detect] is set to “AF”, “👤 AF” appears.
 - When [Main Menu] → [Camera Function] → [User Switch Set] → [Face Detect] is set to “AF&AE”, “👤 AE±0” appears.
- If you select the person nearest to the center of the screen, an orange frame will appear on his face.
- Focus will be automatically adjusted for the selected person.

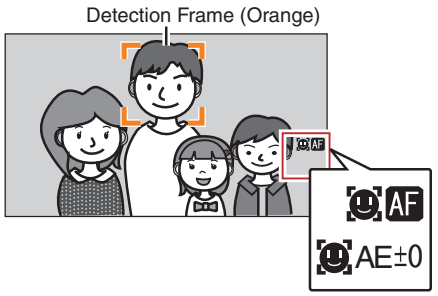

Memo : _____

- If the detection frame does not appear, make sure that the [AUTO FOCUS/11] switch is set to “ON”. Also, if [Face Detect] is set to “AF&AE”, set at least one of the iris, gain, and electronic shutter control items to the automatic adjustment mode.
(☞ P57 [Adjusting the Brightness Automatically])
(☞ P58 [Auto Iris (Automatic Adjustment Mode)])
(☞ P59 [Automatic Gain Mode (Automatic Gain Adjustment)])
(☞ P62 [Automatic Shutter Mode (Automatic Shutter Adjustment)])

Selecting Specific Person from Several Persons

1 Hold down the user button that is assigned with “Face Detect”.

- The camera recorder will enter face selection mode and the face detection icon (👤) will blink.
- An orange frame will appear on the face of the person nearest to the center of the screen. Blue frames will appear on the faces of others.

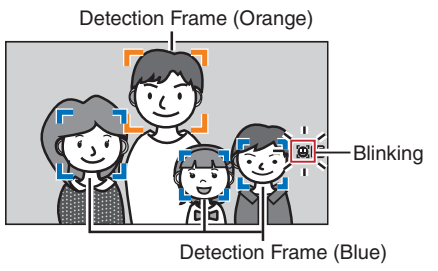

2 Select a specific portrait subject.

- Use the cross-shaped button (◀▶▲▼) to select a person.
- An orange frame will appear on the face of the selected person and focus will be automatically adjusted.

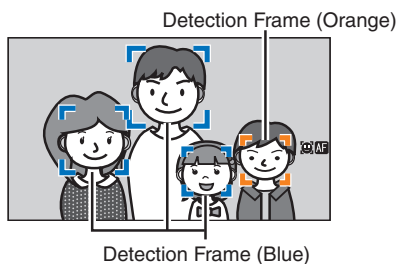

3 Press the Set button (●) to confirm the person for face detection.

Memo : _____

- Press the [CANCEL] button to cancel the selection.
- You can specify the detection sensitivity and the operation speed after losing sight of the face using [Main Menu] → [Camera Function] → [User Switch Set] → [Face Detect] → [Sensitivity] and [Hysteresis].

(☞ P112 [Sensitivity])

(☞ P112 [Hysteresis])

Adjusting the Brightness

Adjust the brightness using Iris, Gain, Shutter speed and ND filter according to the brightness of the object.

Adjusting the Brightness Automatically

When the [FULL AUTO ON/OFF] switch is set to “ON”, Iris, Gain, Shutter speed and ND filter are automatically adjusted according to the brightness of the object to maintain optimum brightness.

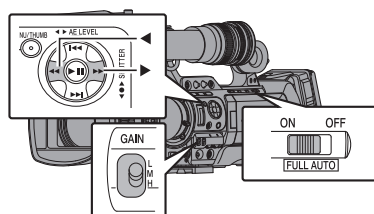

Memo : _____

- You can use the cross-shaped button (◀▶) on the side of the camera recorder to set the target level (brighter/darker) to maintain optimum brightness during automatic adjustment. (☞ P109 [AE Level])
- The convergence speed of the automatic adjustment for gain, shutter and iris can be set in the menu. (☞ P109 [AE Speed])
- If one or more of the items (Gain, Iris and Shutter) have been set to “Auto”, the value of the corresponding items when the user button that is assigned “AE Lock” is pressed can be fixed. (☞ P112 [AE Lock])
- The brightness varies depending on the various settings of the [FULL AUTO] item in the [Camera Function] menu. (☞ P113 [FULL AUTO Item])

Adjusting the Brightness Manually

When the [FULL AUTO] switch is set to “OFF”, some or all of the items (Iris, Gain and Shutter Speed) can be manually adjusted.

(☞ P58 [Adjusting the Iris])

(☞ P59 [Setting the Gain])

(☞ P60 [Setting the Electronic Shutter])

Memo : _____

- If Iris, Gain and Shutter Speed are manually adjusted, the [AE Level] setting is temporarily disabled.

Adjusting the Iris

You can adjust the aperture of the lens iris manually or automatically according to the brightness of the object.

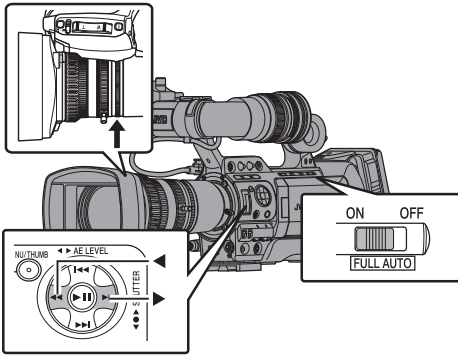

Auto Iris (Automatic Adjustment) Mode

The iris is automatically adjusted according to the brightness of the object.

1 Set the [IRIS A/M] mode selection switch on the lens to “A”.

The camera recorder switches to the Auto Iris mode, and the **A** icon appears on the screen.

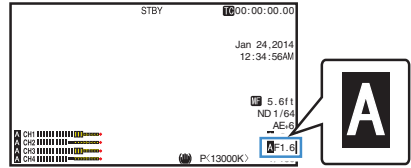

Manual Iris (Manual Adjustment) Mode

The aperture value (F-number) of the lens can be set manually.

1 Set the [IRIS A/M] mode selection switch on the lens to “M”.

The camera recorder switches to the Manual Iris mode, and the **A** icon on the screen disappears.

2 Turn the iris ring on the lens to adjust the iris manually.

The open F-number of the supplied lens varies with the zoom position. **LENS**

Wide [W] end : F1.6
Tele [T] end : F3.0

F-number	Description
Decrease	The subject appears brighter. The focused range becomes sharper, while the background is blurred to produce a soft image.
Increase	The subject appears darker. Background of image becomes focused as well.

Memo : _____

- Set the [FULL AUTO] switch on the camera recorder to “ON” to enter Auto Iris mode (automatic adjustment mode). The iris is automatically adjusted according to the brightness of the object. In this case, operation of the [IRIS A/M] mode selection switch and [IRIS] button on the lens is disabled.
- The iris open/close limit can be set in [Main Menu] → [Camera Function] → [Auto Iris Limit (OPEN)]/[Auto Iris Limit (CLOSE)] during Auto Iris.
(P109 [Auto Iris Limit (OPEN)])
(P109 [Auto Iris Limit (CLOSE)])
- You can use the cross-shaped button (◀▶) on the side control panel to set the target level (brighter/darker) of the auto iris.
(P109 [AE Level])
- The convergence speed of the auto iris can be set in the menu.
(P109 [AE Speed])

Memo : _____

- Even while in the Manual Focus mode, pressing the [IRIS] button on the lens or the user button assigned with the [One Push Iris] function switches the camera recorder to the One-push Auto Iris mode.
- Even while in the Manual Focus mode, pressing and holding the [IRIS] button on the lens or the user button assigned with the [One Push Iris] function switches the camera recorder to the Push Auto Iris mode.

One Push Auto Iris LENS

When the camera recorder is in the Manual Iris mode, press the [IRIS] button on the lens to adjust the iris according to the brightness of the subject.

Memo : _____

- “One Push Iris” can also be assigned to other user buttons.
(☞ P42 [Assignment of Functions to User Buttons])

Push Auto Iris

When the camera recorder is in the Manual Iris mode, press and hold the [IRIS] button on the lens to change to the Auto Iris mode temporarily. The iris will be automatically adjusted according to the brightness of the subject.

Memo : _____

- “One Push Iris” can also be assigned to other user buttons.
(☞ P42 [Assignment of Functions to User Buttons])

About the Iris F-number

Blurry effects due to “small aperture diffraction” may occur when the diameter of the iris becomes too small. When this phenomenon occurs, the F-number on the screen turns gray to warn you that the diffraction F-number of the iris has been exceeded.

You are recommended to make appropriate use of ND filters to prevent the F-number from turning gray.

Setting the Gain

This function electrically boosts the light sensitivity when there is insufficient illumination on the object. You can set the gain of the video amplifier according to the brightness of the object. Select the setting mode according to your shooting conditions.

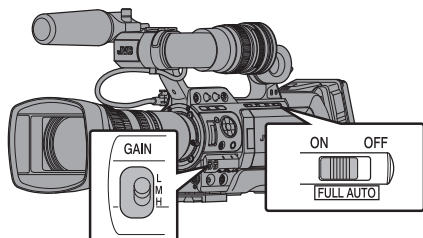

Manual Gain Mode (Manual Gain Switching)

- Select the gain level of the video amplifier using the [GAIN L/M/H] selection switch on the camera recorder.
- The  icon on the screen disappears.
- The default positions of the switch are as follows.

[L] : 0dB
[M] : 6dB
[H] : 12dB

Memo : _____

- You can change the gain value of each position in the menu. Increasing the sensitivity causes the screen to appear grainier.
- The camera recorder switches to the Auto Gain mode when the gain value is set to “ALC”.
(☞ P109 [GAIN L, GAIN M, GAIN H])

Automatic Gain Mode (Automatic Gain Adjustment)

1 Set the [FULL AUTO] switch to “ON”.

- The camera recorder switches to the Auto Gain Adjustment mode (fixed at “ALC”), and the gain of the video amplifier is automatically set according to the brightness of the subject. In this case, the [GAIN L/M/H] selection switch on the camera recorder is disabled.
- The  icon appears on the screen.

Memo : _____

- The upper limit of the gain setting value during ALC operation can be set in [Main Menu] → [Camera Function] → [ALC Limit].
(☞ P109 [ALC Limit])
- When [Camera Function] → [FULL AUTO] → [Gain] is set to “SW Set”, the gain value can be altered using the [GAIN L/M/H] selection switch even when the [FULL AUTO] switch on the camera body is set to “ON”.
(☞ P113 [Gain])
- You can switch to the Auto Gain mode by setting the items in [Camera Function] → [GAIN L], [GAIN M], and [GAIN H] to “ALC”.
(☞ P109 [GAIN L, GAIN M, GAIN H])

Setting the Electronic Shutter

You can change the shutter speed (time for each shooting frame) using the electronic shutter function. Electronic shutter can be adjusted manually or automatically.

Manual Shutter Mode (Manual Shutter Switching)

Use the Set button (●) to switch between the shutter modes and the cross-shaped button (▲▼) to switch between the speeds.

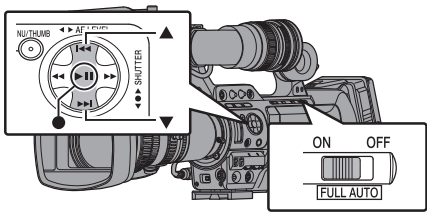

Switching Shutter Mode

Press the Set button (center of the cross-shaped button) to turn ON/OFF the shutter.

- Memo : _____
- When the shutter is ON, “Step”, “Variable”, or “EEI” may be selected using [Camera Function] → [Shutter] menu. “Step” is the factory default. (☞ P108 [Shutter])

Switching Shutter Speed

When shutter is ON, use the cross-shaped button (▲▼) to set the shutter speed. Shutter speed differs according to the video format and variable frame rate settings.

- Memo : _____
- To display Shutter in angle (DEG), set [A]Frame & Bit Rate] to 25p(XHQ), 25p(UHQ), 25p(HQ), 24p(XHQ), 24p(UHQ), or 24p(HQ), and set [Shutter] in [LCD/VF] → [Display Settings] to “DEG”. (☞ P133 [A Frame & Bit Rate]) (☞ P124 [Shutter])

During Modes Other Than Variable Frame Rec

Shutter	Resolution/ Frame Rate	720/60p	720/50p	720/24p 1080/24p
		720/30p 1080/60p 1080/60i 1080/30p	720/25p 1080/50p 1080/50i 1080/25p	
▲ ON (Step)		—	—	1/10000
				1/4000
				1/2000
		1/10000	1/10000	1/1000
		1/4000	1/4000	1/500
		1/2000	1/2000	1/250
		1/1000	1/1000	1/120
		1/500	1/500	1/100
		1/250	1/250	1/60
		1/120	1/120	1/54
		1/100	1/100	1/50
	(Standard)	1/60	1/50	1/48
		1/30	1/25	1/24
	1/15	1/12.5	1/12	
	1/7.5	1/6.25	1/6	
▼ ON (Variable)	(Upper limit)	1/10227		1/10843
		~		
	Default values	1/60.00	1/50.00	1/48.00
		~		
	(Lower limit)	1/30.07	1/25.05	1/24.05
OFF		1/60	1/50	1/48

- Memo : _____
- The operations of the cross-shaped button (▲▼) and Set button (●) are disabled in the following cases.
 - During clip preview
 - During display of the USB switching confirmation screen
 - During display of the formatting confirmation screen
 - When selecting a face using face detection
 - When selecting a photometry area with [Spot Meter] set to “Manual”

During Variable Frame Rec



Shutter	Resolution/Frame Rate	720/30p, 720/24p, 1080/30p, 1080/24p								
		Frame rate	60, 30, 15	54, 27	50, 25	48, 24, 12, 6	45, 22.5	40, 20, 10	36, 18	32, 2
▲ ON (Step)		—	—	—	—	—	—	—	—	1/10000
		—	—	—	—	—	—	—	1/10000	1/4000
		—	—	—	—	—	—	1/10000	1/4000	1/2000
		—	—	—	—	—	1/10000	1/4000	1/2000	1/1000
		—	—	—	—	1/10000	1/4000	1/2000	1/1000	1/500
		—	—	1/10000	1/4000	1/2000	1/1000	1/500	1/250	1/120
		1/10000	1/4000	1/2000	1/1000	1/500	1/250	1/120	1/100	1/60
		1/4000	1/2000	1/1000	1/500	1/250	1/120	1/100	1/60	1/54
		1/2000	1/1000	1/500	1/250	1/120	1/100	1/60	1/54	1/50
		1/1000	1/500	1/250	1/120	1/100	1/60	1/54	1/50	1/48
		1/500	1/250	1/120	1/100	1/60	1/54	1/50	1/48	1/45
		1/250	1/120	1/100	1/60	1/54	1/50	1/48	1/45	1/40
		1/120	1/100	1/60	1/54	1/50	1/48	1/45	1/40	1/36
		1/100	1/60	1/54	1/50	1/48	1/45	1/40	1/36	1/32
		(Standard)	1/60	1/54	1/50	1/48	1/45	1/40	1/36	1/32
			1/30	1/27	1/25	1/24	1/22.5	1/20	1/18	1/16
	1/15	1/13.5	1/12.5	1/12	1/11.25	1/10	1/9	1/8		
	1/7.5	1/6.75	1/6.25	1/6	1/5.625	1/5	1/4.5	1/4		
▼										
▲ ON (Variable)	(Upper limit)	1/10227			1/10843	1/10227	1/10843	1/10227	1/10843	
		~								
▼	(Lower limit)	1/60.00	1/54.00	1/50.00	1/48.00	1/45.00	1/40.00	1/36.00	1/32.00	
OFF		1/60	1/54	1/50	1/48	1/45	1/40	1/36	1/32	

Shutter	Resolution/Frame Rate	1080/25p 720/25p						
		Frame rate	50, 25, 12.5	48, 24, 6	45, 22.5	40, 20, 10	36, 18	32, 2
▲ ON (Step)		—	—	—	—	—	—	1/10000
		—	—	—	—	—	1/10000	1/4000
		—	—	—	—	1/10000	1/4000	1/2000
		—	—	—	1/10000	1/4000	1/2000	1/1000
		—	1/10000	1/4000	1/2000	1/1000	1/500	1/250
		1/10000	1/4000	1/2000	1/1000	1/500	1/250	1/120
		1/4000	1/2000	1/1000	1/500	1/250	1/120	1/100
		1/2000	1/1000	1/500	1/250	1/120	1/100	1/50
		1/1000	1/500	1/250	1/120	1/100	1/50	1/48
		1/500	1/250	1/120	1/100	1/50	1/48	1/45
		1/250	1/120	1/100	1/50	1/48	1/45	1/40
		1/100	1/50	1/48	1/45	1/40	1/36	1/32
		(Standard)	1/50	1/48	1/45	1/40	1/36	1/32
			1/25	1/24	1/22.5	1/20	1/18	1/16
			1/12.5	1/12	1/11.25	1/10	1/9	1/8
			1/6.25	1/6	1/5.625	1/5	1/4.5	1/4
▼								
▲ ON (Variable)	(Upper limit)	1/10227	1/10843	1/10227	1/10843	1/10227	1/10843	
		~						
▼	(Lower limit)	1/50.00	1/48.00	1/45.00	1/40.00	1/36.00	1/32.00	
OFF		1/50	1/48	1/45	1/40	1/36	1/32	







Automatic Shutter Mode (Automatic Shutter Adjustment)

1 Set the [FULL AUTO] switch to “ON” to set to the Auto Shutter mode.

- The  icon appears on the screen.
- The camera recorder enters the Auto Shutter mode. The shutter speed is automatically adjusted according to the brightness of the subject.

Switching of shutter speed with the cross-shaped button () and switching of shutter mode with the Set button () are disabled.

Memo : _____

- You can set the controllable range for the Automatic Shutter in [Main Menu] → [Camera Function] → [EEL Limit].
( P109 [EEL Limit])
- When [Camera Function] → [FULL AUTO] → [Shutter] is set to “SW Set”, the shutter mode can be adjusted using the Set button () and the shutter speed can be altered using the cross-shaped buttons () even when the [FULL AUTO] switch on the camera body is set to “ON”.
- Setting [Camera Function] → [FULL AUTO] → [Shutter] to “EEI” switches the camera recorder to the Automatic Shutter Adjustment mode. In this case, adjustment of the shutter mode using the Set button () and adjustment of the shutter speed with the cross-shaped buttons () will be disabled.
( P113 [Shutter])
- You can also switch to the Auto Shutter mode by setting [Camera Function] → [Shutter] to “EEI”.
( P108 [Shutter])

Setting the ND Filter

Use the ND filter to keep the lens aperture in the appropriate range.
Switch according to the brightness of the object.
When the position on the switch is changed, the selected position of the ND filter is displayed on the LCD monitor and viewfinder screen.
(Display 2 screen)

Memo : _____

- When [Main Menu] → [LCD/VF] → [Display Settings] → [ND Filter] is set to “Off”, the position of the ND filter will not be displayed.
( P122 [ND Filter])

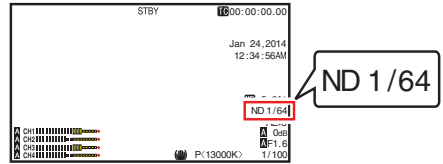
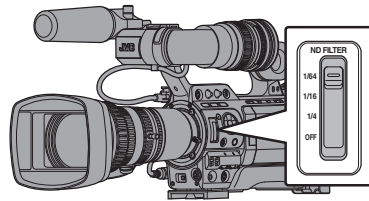

Memo : _____

- It is recommended to use the ND filter to set the lens aperture to less than F8.

ND Filter Warning Display

In order to adjust the amount of light when you are shooting at a relatively bright location, the diameter of the iris may become extremely small, causing blurry effects to occur as a result.

This phenomenon is known as “small aperture diffraction”. You can make appropriate use of ND filters to prevent it from occurring.

This unit displays an ND filter warning when necessary to prompt you to select an appropriate ND filter.

- 1 Set [Main Menu] → [LCD/VF] → [Display Settings] → [ND Filter] to “On+Assist”.
( P122 [ND Filter])
- 2 When the iris diameter becomes too small while adjusting the light intensity, or when an ND filter is used in a dimly-lit location, the ND filter display starts blinking.

Adjusting the White Balance

Adjust the white balance according to the color temperature of the lighting. You can select the adjustment mode according to the shooting conditions.

As the color of the light (color temperature) varies according to the light source, it is necessary to readjust the white balance when the main light source illuminating the subject changes.

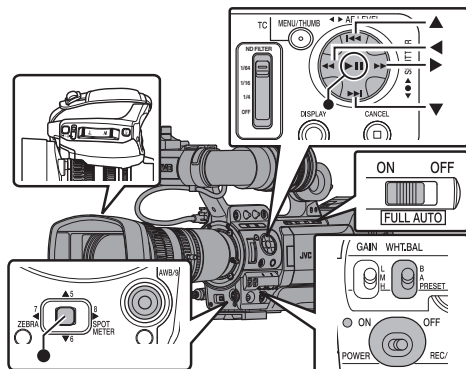

Manual White Balance Mode (Manual Switching)

- You can select the white balance with the [WHT.BAL B/A/PRESET] switch.
- Use the [WHT.BAL B/A/PRESET] switch to select "PRESET" (preset mode), "A" (memory A mode), or "B" (memory B mode).
- Select [Back], and press the Set button (●) to return to the [White Balance] menu.

Memo : _____

- You can set the Full Auto White Balance to either [A], [B], or [PRESET] in [Camera Function] → [FAW].
(☞ P114 [White Balance])
- In the FAW (Full Auto White Balance) mode, the color temperature of the video is sampled constantly and automatically to obtain the most appropriate white balance level.
- When [Camera Function] → [FULL AUTO] → [White Balance] is set to "FAW" and the [FULL AUTO] switch on the camera recorder is set to "ON", the setting is fixed at "FAW".

Preset Mode (PRESET)

- Two different color temperature settings are registered on this camera recorder. You can switch between them using the user button assigned with the "AWB" function. (Default setting: "3200K" ↔ "5600K")
- The color temperature changes each time you press the user button assigned with "AWB". ("Preset Temp." ↔ "Alternative Temp.")

- 1 Set the [WHT.BAL B/A/PRESET] switch to "PRESET".
- 2 Press the user button that is assigned with "AWB".

Setting the [Preset Temp.] or [Alternative Temp.] Values

You can change both the color temperature settings in the Preset mode in the menu.

- 1 Open the [Preset Temp.] or [Alternative Temp.] menu.
 - Select [Main Menu] → [Camera Process] → [White Balance] → [Preset Temp.] and [Alternative Temp.], and press the Set button (●).
 - The Color Temperature setting screen appears.

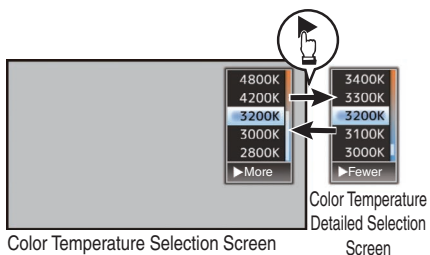

- 2 Select the color temperature.
 - When selecting from a setting value (Color Temperature Selection screen), use the cross-shaped button (▲▼) to select the color temperature. [Setting Values: 7500K, 6500K, 5600K, 5200K, 4800K, 4200K, ●3200K, 3000K, 2800K]
 - To select detailed values (Color Temperature Detailed Selection screen)
 - Press the cross-shaped button (▶) to display the Color Temperature Detailed Selection screen.
 - Use the cross-shaped button (▲▼) to select a color temperature. [Setting Values: 2300K to 15000K (in 100K increments)]

Memo : _____

- Use the cross-shaped button (▶) to switch between the Color Temperature Selection screen and the Color Temperature Detailed Selection screen.
- If [White Balance] has been assigned to the user button, pressing the assigned user button will display the Color Temperature Selection screen.
(☞ P42 [Assignment of Functions to User Buttons])

Memory A Mode (A), Memory B Mode (B)

- Set to the white balance saved in Memory A or Memory B.
- When the [WHT.BAL B/A/PRESET] switch is set to “A” or “B”, pressing the user button assigned with “AWB” executes Auto White Balance. The white balance will be automatically adjusted and the adjusted value will be saved in Memory A or Memory B.

1 Prepare the camera recorder.

- ① Set the [POWER ON/OFF] switch to “ON”.
- ② Set the [IRIS A/M] mode switch on the lens to “A”.
- ③ Set the [FULL AUTO] switch to “OFF”.

2 Set the [ND FILTER] switch according to the lighting.

(☞ P62 [Setting the ND Filter])

3 Set the [WHT.BAL B/A/PRESET] switch to “A” or “B”.

4 Locate a place with similar lighting conditions as the object to be shot, place a white object near the center of the screen and zoom in to fill the screen with white.

5 Press the [AWB/9] (Auto White Balance) button.

- The white detection frame appears when Auto White Balance is activated. Fill the frame with white completely.
- While Auto White is starting up, “A<👁>” or “B<👁>” appears on the screen. (👁 mark appears blinking)
- After the correct white balance is obtained, an estimated value of the current color temperature is displayed.

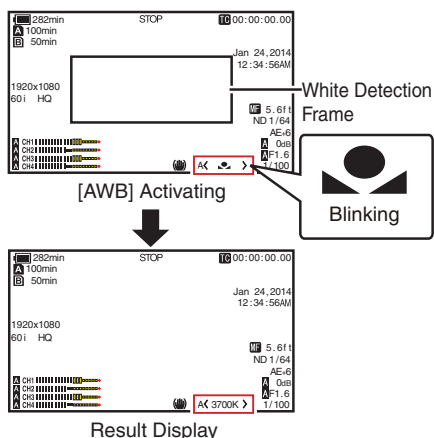

Caution : _____

- Do not use highly reflective objects, such as metals. Doing so may result in improper white balance adjustment.
- The Auto White Balance function cannot provide optimum white balance with an object outside the adjustment range, for example when it contains only a single color or not enough white color.

Error Message

If the Auto White Balance adjustment is not correctly completed, one of the following messages will appear for about 3 seconds.

Message	Status
Auto White * NG: Object (*A or B)	Displayed when there is not enough white color on the object, or when the color temperature is not suitable. Use another white object and adjust the white balance again.
Auto White * Error: Low Light (*A or B)	Displayed when the lighting is dark. Increase the lighting and adjust the white balance again.
Auto White * Error: Over Light (*A or B)	Excessive illumination. Displayed when the lighting is too bright. Decrease the lighting and adjust the white balance again.

White Paint Adjustment

You can fine-tune the white balance saved in Memory A or Memory B.

- 1 Select [Main Menu] → [Camera Process] → [White Balance] → [AWB Paint] and press the Set button (●).

The White Paint Adjustment screen appears.

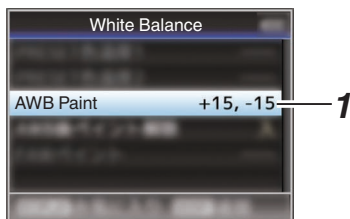

- 2 Adjust the R and B values.

Use the cross-shaped button (▲▼) to adjust R value and (◀▶) to adjust B value.

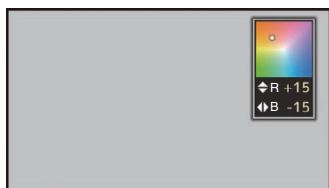

- 3 Press the Set button (●).

Returns to the [White Balance] screen.

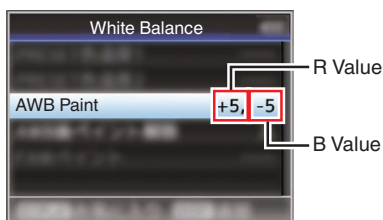

Memo : _____

- Selecting [AWB] will usually clear the White Paint Adjustment value. But when [Main Menu] → [Camera Process] → [White Balance] → [Clear Paint After AWB] is set to "Off", values will not be cleared even when [AWB] is selected. (☞ P118 [Clear Paint After AWB])
- If [White Balance] has been assigned to the user button, pressing the assigned user button will display the AWB Paint Adjustment screen. (☞ P42 [Assignment of Functions to User Buttons])

Automatic White Balance Mode (FAW: Fulltime Auto White balance)

- 1 Assign "FAW" (Full Auto White Balance) to one of the three [WHT.BAL B/A/PRESET] switches.

- You can set the Full Auto White Balance feature to either [A], [B], or [PRESET] in [Camera Function] → [FAW].

(☞ P109 [FAW])

- "<FAW>" appears on the screen.
- Set the [FULL AUTO ON/OFF] switch on the camera recorder to "ON" to enter Automatic White Balance mode. An appropriate white balance is automatically adjusted according to the color temperature of the lighting on the object.
- In this case, switching of the white balance with the [WHT.BAL B/A/PRESET] switch is disabled.

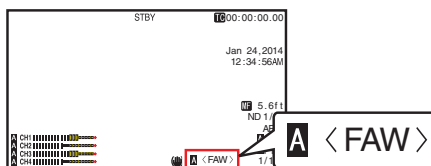

Caution : _____

- The accuracy of [FAW] is inferior to that of Auto White Balance.
- When the power of the camera recorder is turned on with the [FAW] mode selected, it takes about 15 seconds for the colors to stabilize.

Memo : _____

- When [Main Menu] → [Camera Function] → [User Switch Set] → [AE Lock] is set to "AE/WB", the white balance when the user button that is assigned [AE Lock] is pressed can be fixed. (☞ P112 [AE Lock])
- You can switch the white balance using the [WHT.BAL B/A/PRESET] switch when [Camera Function] → [FULL AUTO] → [White Balance] is set to "SW Set". (☞ P114 [White Balance])
- If [White Balance] has been assigned to the user button, pressing the assigned user button will display the FAW Paint Adjustment screen. (☞ P42 [Assignment of Functions to User Buttons])

FAW Paint Adjustment

You can fine-adjust the white balance that was automatically adjusted.

- 1 Select [Main Menu] → [Camera Process] → [White Balance] → [FAW Paint] and press the Set button (●).

The FAW Paint Adjustment screen appears.

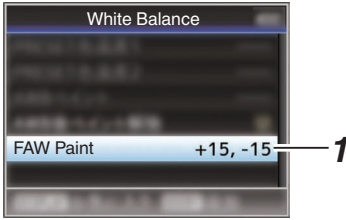

- 2 Adjust the R and B values.

Use the cross-shaped button (▲▼) to adjust R value and (◀▶) to adjust B value.

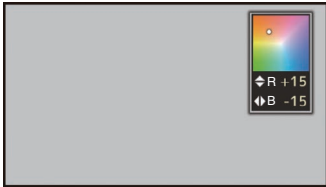

- 3 Press the Set button (●).

Returns to the [White Balance] screen.

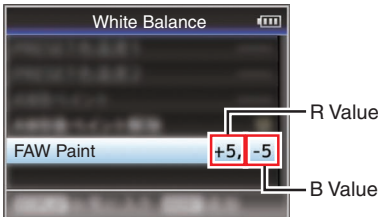

White Shading Adjustment

- Adjustment of white shading is needed when you have changed the lens.
- Although white balance may be appropriate at the center of the image, this may not be the case at the top and bottom areas. If this is the case, the image will appear greenish or yellowish. This phenomenon is due to the characteristics of the lens. The process of correcting this phenomenon is referred to as white shading adjustment.
- Perform this process after adjusting the white balance.

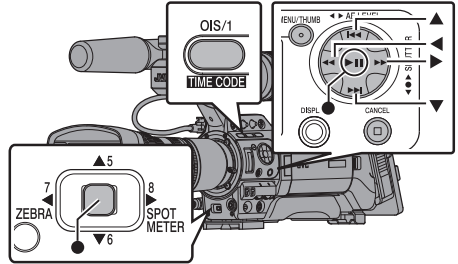

Setup Prior Adjustment

- 1 Obtain the white balance on the camera. (P64 [Memory A Mode (A), Memory B Mode (B)])
- 2 Set the control of the camera lens as follows.
 - ① Set the iris to F4.0 or narrower to obtain the appropriate brightness. If the brightness is insufficient at F4.0, obtain the appropriate brightness such as by adjusting the lighting.
 - ② When using a zoom lens, set to the center of the zoom adjustment range.
- 3 Fill the monitor screen with a pattern box of a uniform light source, or a piece of white (plain) paper that is uniformly illuminated.
- 4 Set the chroma level of the monitor to the maximum.
- 5 Check the monitor screen.
 - There is no need for adjustment if there is no color at the top and bottom of the screen.
 - If the top of the screen is greenish and the bottom is reddish or vice versa, continue this adjustment.

Adjusting the White Shading

- 1 Set [Main Menu] → [Camera Process] → [White Balance] → [Shading] to “On”.
- 2 Select [Adjust...] in [Shading] and press the Set button (●).
The White Shading Adjustment screen appears.

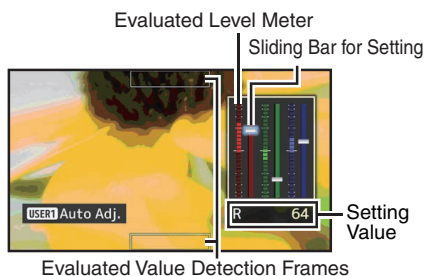

- 3 Press the [OIS/1] button to set to perform automatic adjustment.
You can use the R, G, B channels individually to adjust the value of the evaluated level meter up to a margin error of ± 1 from the median value.
- 4 Adjust manually.
 - If you want to adjust manually after automatic adjustment is performed, follow the steps below.
 - You are recommended to adjust the G (green) level only.
 - If manual adjustment is not necessary, adjustment is complete at step 7.
- 5 Use the cross-shaped buttons (◀▶) to select the item to adjust from [R]/[G]/[B].
- 6 Adjust the setting value using the cross-shaped buttons (▲▼).
 - Adjust the sliding bar for setting while referring to the evaluated level meter.
 - Adjust the values such that the evaluated value falls almost at the center of the meter using the ▼ cross-shaped button if the evaluated value of the channel to be adjusted is larger than the median value, and the ▲ cross-shaped button if the evaluated value is smaller than the median value.
- 7 Press the Set button (●) to save the setting.
 - Make sure to press the Set button (●) to save the setting.
 - Pressing the [CANCEL] button discards the setting and returns to the menu screen at the next higher level.

Memo : _____

- There may be some delay in the changes of the evaluated value after pressing the cross-shaped button (▲▼).
- Increasing the setting value suppresses the colors at the bottom and enhances the colors on top.
- Adjustment is not possible in the following cases. An error message will appear.
 - When the top and bottom ends of the frame are overexposed
 - When the top and bottom ends of the frame are underexposed
 - When there is significant difference in the level between the top and bottom ends of the frame

What is evaluated value?

This is a relative value (difference between the top and bottom ends) with respect to the average value of the R, G, B channels within the evaluated value detection frames at the top and bottom of the LCD monitor or viewfinder.

The evaluated value is positioned higher than the center of the evaluated level meter when the level at the top is higher than that at the bottom end. Similarly, the evaluated value is positioned lower than the center of the evaluated level meter when the level at the top is lower than that at the bottom end.

Adjust the evaluated value such that it falls almost at the center of the meter.

Adjusting the Camera Image

The picture quality of the camera can be set using the [Camera Process] menu.

As the adjustments are shown on the screen, you can adjust the values while checking the picture quality on the camera.

- [Detail]
- [Master Black]
- [Black Toe]
- [Knee]
- [White Clip]
- [Gamma]
- [WDR]
- [White Balance]
- [Color Matrix]
- [Color Gain]
- [Reverse Picture]
- [Shooting Mode]

Memo : _____

- For details of the respective items, see the [Camera Process] menu.
(P114 [Camera Process Menu])

Using the Image Stabilizer

LENS

Reduces blurring of images due to camera shake.

1 Check whether the image stabilizer feature is turned ON or OFF.

If the image stabilizer icon (👉/👉👉👉) does not appear on the screen display, the image stabilizer function is OFF.

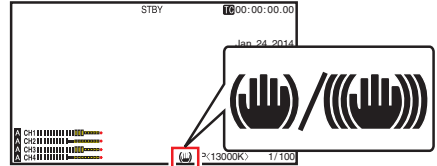

2 Press the [OIS/1] button to turn ON the image stabilizer feature (when image stabilizer feature is OFF).

The image stabilizer feature switches between ON and OFF with every press of the [OIS/1] button.

- OFF:
Use this setting when the camera recorder is secured, such as when using a tripod.
- ON:
Reduces blurring of images due to camera shake.

Memo : _____

- Select [Main Menu] → [Camera Function] → [OIS] → [Level] to set the correction level.
(P108 [Level])
- Correction by this feature may not be sufficient when camera shake is too strong.
- "OIS" is assigned to [OIS/1] button in factory default.
- "OIS" can also be assigned to other user buttons.
(P42 [Assignment of Functions to User Buttons])

Audio Recording

You can record audio from the four channels (CH-1/CH-2/CH-3/CH-4) in synchronization with the video images on this camera recorder. Select from the three options below to record the audio.

- Microphone connected to [AUX] terminal
- Microphone connected to [INPUT1] terminal
- Microphone connected to [INPUT2] terminal

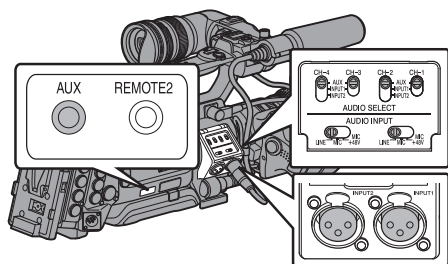

Setting the Number of Recording Channels

- Set accordingly for slot A and slot B.
- Set the number of recording channels in [Main Menu] → [System] → [Record Set] → [Record Format] → [A]Audio/[B]Audio].
(☞ P133 [A Audio])
(☞ P134 [B Audio])

Selecting Audio to Be Recorded in Each Channel

Select the audio to be recorded in CH-1/CH-2/CH-3/CH-4.

-	Switch Setting	Audio Input
CH-1 CH-3	AUX	Audio input from [AUX] terminal
	INPUT1	Audio input from [INPUT1] terminal
CH-2 CH-4	AUX	Audio input from [AUX] terminal
	INPUT1	Audio input from [INPUT1] terminal
	INPUT2	Audio input from [INPUT2] terminal

Memo :

- Set the reference input level of “AUX” using [Main Menu] → [A/V Set] → [Audio Set] → [AUX Gain].
(☞ P127 [AUX Gain])

Setting for [INPUT1]/[INPUT2] Input Channel

Set [AUDIO INPUT] signal selection switch 1 or 2 according to the devices to be connected to the [INPUT1] and [INPUT2] terminals.

Setting	Description
[LINE]	Use this setting when connecting to an audio device or other equipment. The reference input level is +4 dBu.
[MIC]	Use this setting when connecting to a dynamic microphone.
[MIC+48V]	Use this setting when connecting to a microphone (phantom microphone) that requires a +48 V power supply.

Memo :

- When “MIC” or “MIC+48V” is selected, set the reference input level in [Main Menu] → [A/V Set] → [Audio Set] → [Input1 Mic Ref.]/[Input2 Mic Ref.].
(☞ P127 [Input1 Mic Ref.])
(☞ P127 [Input2 Mic Ref.])

Caution :

- When connecting a device that does not require a +48 V power supply, make sure that it is not set to the “MIC+48V” position.
- When the [AUDIO INPUT] signal selection switch 1 or 2 is set to “MIC”, check to ensure that a microphone is connected to the [INPUT1]/[INPUT2] terminal. If you increase the recording level when a microphone is not connected, noise from the input terminal may be recorded.
- When a microphone is not connected to the [INPUT1]/[INPUT2] terminal, set the [AUDIO INPUT] signal selection switch 1 or 2 to “LINE”.

Adjusting Audio Recording Level

- You can select to adjust the audio recording levels for each of the four channels (CH-1/CH-2/CH-3/CH-4) manually or automatically.
- Set CH-1/CH-2 using the switch, and CH-3/CH-4 using the menu.

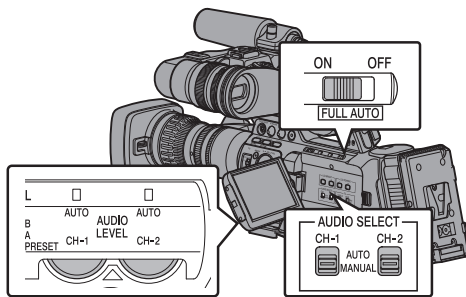

For CH-1/CH-2

■ Adjusting manually

- 1 Set the [AUDIO SELECT CH-1/CH-2 AUTO/MANUAL] selection switch to “MANUAL” for the channel to be adjusted manually.
- 2 Turn the [AUDIO LEVEL CH-1/CH-2] adjustment knob corresponding to the channel to adjust the level.

When [Audio Set] → [CH1 Limiter]/[CH2 Limiter] → [Threshold Level] is set to “Off”, adjust such that the audio level meter does not light up at -2 dB even for loud sounds.

(☞ P128 [CH1/2 Limiter Mode])

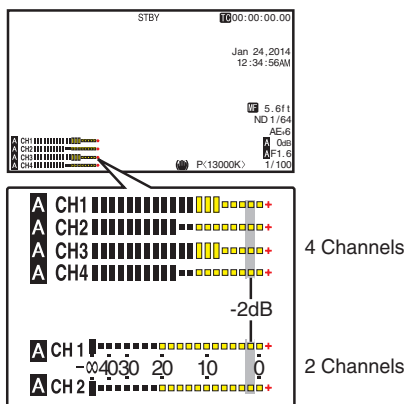

Memo : _____

- For the recorded audio, you can set items such as [Threshold Level], [Attack Time] or [Decay Time] in [CH1 Limiter] or [CH2 Limiter].
- If [CH1 Limiter]/[CH2 Limiter] → [Threshold Level] is set to a value other than “Off”, the limiter operates according to the value set.
- You can adjust the level manually during the recording, recording standby, and stop modes. (☞ P128 [CH1 Limiter/CH2 Limiter])
- Set the reference audio level of [CH-1] and [CH-2] to be recorded on SD cards in the [Main Menu] → [A/V Set] → [Audio Set] → [CH1/2 Ref. Level] menu to “-20dB”, “-18dB”, or “-12dB”. (common for CH-1/CH-2) (☞ P127 [CH1/2 Ref. Level])

■ Adjusting automatically

Set the [AUDIO SELECT CH-1/CH-2 AUTO/MANUAL] selection switch to “AUTO” or the [FULL AUTO] switch to “ON” to enter Automatic Adjustment mode. The audio recording level is set automatically according to the input level.

Memo : _____

- When the [FULL AUTO] switch is set to “ON”, mode switching of the [AUDIO SELECT CH-1/CH-2 AUTO/MANUAL] selection switch is disabled.
- When [Main Menu] → [A/V Set] → [Audio Set] → [CH1 Limiter]/[CH2 Limiter] → [Threshold Level] is set to “Off” while in the automatic adjustment mode, the limiter operates at -6dBFS.
- If [CH1 Limiter]/[CH2 Limiter] → [Threshold Level] is set to a value other than “Off”, the limiter operates according to the value set. (☞ P128 [CH1 Limiter/CH2 Limiter])
- When [Main Menu] → [Camera Function] → [FULL AUTO] → [Audio] is set to “SW Set”, you can switch the audio recording mode with the [AUDIO SELECT CH-1/CH-2 AUTO/MANUAL] selection switch on the camera recorder even when the [FULL AUTO] switch is set to “ON”. (☞ P114 [Audio])

1 Open the [CH3/4 Input Level] adjustment screen.

- Press the Set button (●) in [Main Menu] → [A/V Set] → [Audio Set] → [CH3/4 Input Level].
- (☞ P127 [CH3/4 Input Level])
- The [CH3/4 Input Level] adjustment screen appears.

Memo : _____

- The input level cannot be set when the [FULL AUTO] switch is set to "ON".

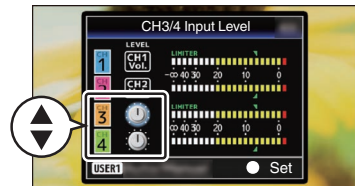

2 Select whether to adjust manually or automatically.

- Use the ▲▼ cross-shaped buttons to select the channel to set.
- Press the [OIS/1] button to switch between Manual and Auto.
- During manual adjustment, adjust the level using the ◀▶ cross-shaped buttons.

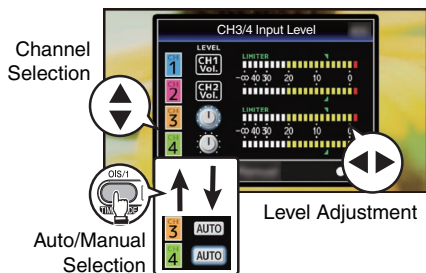

3 Press the Set button (●) to end the adjustment.

- Make sure to press the Set button (●) to save the setting.
- Pressing the [CANCEL] button discards the setting and returns to the menu screen at the next higher level.

Memo : _____

- You can adjust the level manually during the recording, recording standby, and stop modes.
- For the recorded audio, you can set items such as [Threshold Level], [Attack Time] or [Decay Time] in [CH3 Limiter] or [CH4 Limiter].
- If [CH3 Limiter]/[CH4 Limiter] → [Threshold Level] is set to a value other than "Off", the limiter operates according to the value set. (☞ P128 [CH3 Limiter/CH4 Limiter])
- Set the reference audio level of [CH-3] and [CH-4] to be recorded on SD cards in the [Main Menu] → [A/V Set] → [Audio Set] → [CH3/4 Ref. Level] menu to "CH1/2 Link", "CH1/2 -6dB", or "CH1/2 -12dB". (common for CH3/CH4) (☞ P127 [CH3/4 Ref. Level])
- When [Main Menu] → [A/V Set] → [Audio Set] → [CH3 Limiter]/[CH4 Limiter] → [Threshold Level] is set to "Off" while in the automatic adjustment mode, the limiter operates at -6dBFS.
- If [CH3 Limiter]/[CH4 Limiter] → [Threshold Level] is set to a value other than "Off", the limiter operates according to the value set. (☞ P128 [CH3 Limiter/CH4 Limiter])

Audio Output during Recording

- You can check the recorded audio from the monitor speaker or the earphone connected to the [PHONES] terminal.
(P163 [Connecting a Earphone])
- Adjust the volume of the monitor speaker or earphone using the [MONITOR] adjustment knob.

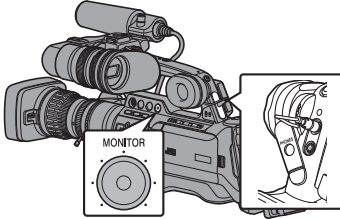

Memo : _____

- The warning tone will not be output during recording.
- Note that raising the volume of the monitor excessively may cause howling with the camera mic.

Time Code and User's Bit

Time code and user's bit data are recorded with the video in this camera recorder. The time code and user's bit are displayed on the viewfinder and LCD monitor during playback or recording. (Display screen)

Displaying Time Code and User's Bit

The time code and user's bit are displayed on the viewfinder and LCD monitor during playback or recording.

The display differs according to the menu settings.

- Set [Main Menu] → [LCD/VF] → [Display Settings] → [TC/UB] to "On".

(P123 [TC/UB])

When "TC" or "UB" is selected, time code or user's bit data is displayed respectively on the display screen.

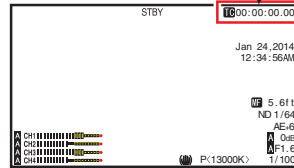

- Select the display using the [TC DISPLAY] switch on the LCD monitor.

Select time code display ([TC]) or user's bit display ([UB]).

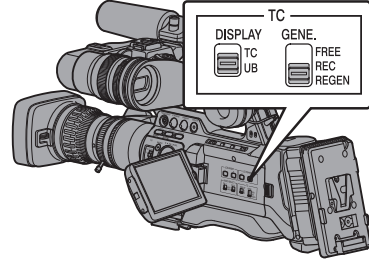

Memo : _____

- Values recorded on the SD card is displayed in Media mode.

Time Code Operation Mode

Three types of time code operation (“FREE”, “REC”, “REGEN”) can be selected with the [TC GENE.] switch.

Setting	Description
FREE	<ul style="list-style-type: none"> The time code operates in the run mode at all times regardless of the recording status. It continues to run even when the power of the camera recorder is turned off. Synchronizes with the external time code when an external time code generator is connected. (☞ P78 [Synchronizing the Time Code with an External Time Code Generator])
REC	<p>The time code operates in the run mode during recording. It continues to run in the order of the recorded clips as long as the SD card is not replaced. If the SD card is removed and recording is made on another card, time code will be recorded on the new card from where it was left off in the previous card.</p>
REGEN	<p>The time code operates in the run mode during recording. When the SD card is replaced, the last time code recorded on the card is read and recorded on a new card so that the time code continues in running order. (☞ P74 [Presetting the Time Code])</p>

Memo : _____

- When [Main Menu] → [System] → [Record Set] → [Rec Mode] is set to “Variable Frame”, “Interval Rec” or “Frame Rec”, and the [TC GENE.] switch is set to “FREE”, Rec Run mode is activated.
(☞ P135 [Rec Mode])
- When [Main Menu] → [System] → [Record Set] → [Record Format] → [A Format]/[B Format] is set to “AVCHD”, Pre Rec enters Free Run mode.
(☞ P133 [A Format])
(☞ P134 [B Format])

Setting Time Code Generator

Presetting the Time Code

- Time code and user’s bit data generated from the internal time code generator are recorded.
- This section describes how to set [TC/UB] → [TC Preset].

(☞ P119 [TC Preset])

Memo : _____

- When the frame rate in [Main Menu] → [System] → [Record Set] → [Record Format] → [A Frame & Bit Rate]/[B Frame & Bit Rate] is set to “50p”, “50i”, “25p” or “24p”, setting to “Drop” is disabled.
(☞ P133 [A Frame & Bit Rate])
(☞ P134 [B Frame & Bit Rate])
- You can configure the setting without accessing the [TC/UB] menu screen.
(☞ P75 [Setting Time Code without Opening the Menu])

Required Settings Before Preset

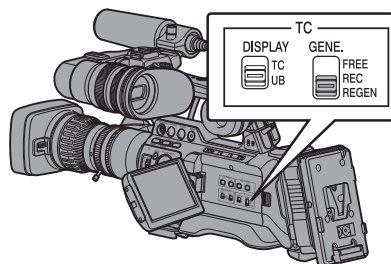

1 Set the [TC GENE.] switch to “REC” or “FREE”.

- [REC]:
Preset data in the time code generator operates in run mode during recording mode. Set this when recording continuous time code in connecting frames.
- [FREE]:
Time code starts to operate in run mode from the preset time in the time code generator.

2 Select the framing mode for the time code generator (only when the frame rate setting is “60” or “30”).

Set using [Main Menu] → [TC/UB] → [Drop Frame].

(P119 [Drop Frame])

• [Drop]:

Sets the run mode of the time code generator to drop frame mode. Use this setting when placing emphasis on the recording time.

• [Non Drop]:

Sets the run mode of the time code generator to non-drop frame mode. Use this setting when placing emphasis on the number of frames.

Memo : _____

Drop frame/non-drop frame mode

- When the frame rate setting in [Main Menu] → [System] → [Record Set] → [Record Format] → [Frame & Bit Rate] is “60p”, “60i”, or “30p”, the actual number of frames per second is approximately 59.94 (29.97). However, the time code processing standard is “60p”, “60i”, or “30p” frames. To make up for the frame number discrepancy, the drop frame mode (Drop) drops the 00 frame and 01 frame every minute except for minutes that are multiples of 10. However, in the case of “60p”, the 00, 01, 02 and 03 frame are dropped.
- The non-drop frame mode (Non Drop) does not drop frames and ignores the discrepancy with the actual time.

Presetting the Time Code

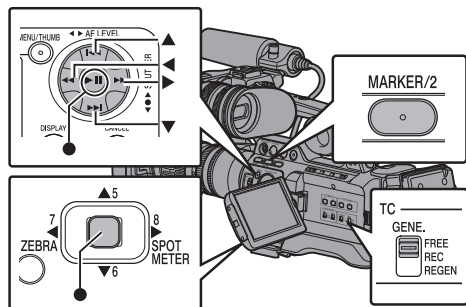

1 Select [Main Menu] → [TC/UB] → [TC Preset] and press the Set button (●).

(P119 [TC Preset])

The [TC Preset] screen appears.

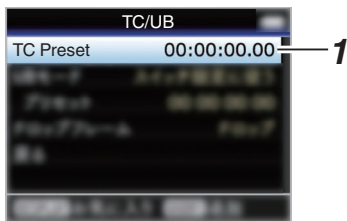

Memo : _____

- When the [TC GENE.] switch is set to “REGEN”, the parameter is displayed as “Regen” and selection is disabled.

2 Set the time code (hour, minute, second, frame).

Use the cross-shaped button (◀▶) to place the cursor at the item to set, then use the cross-shaped button (▲▼) to change the values.

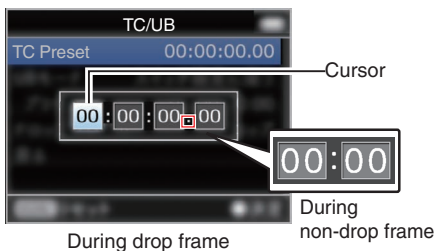

During drop frame

During non-drop frame

Memo : _____

- Press the [MARKER/2] button to reset each digit to “0”. The cursor moves to the time digit (left).

3 Check the values and press the Set button (●).

- The time code is set and the screen returns to [TC/UB].
- To cancel the setting, press the [CANCEL] button.

4 Press the [MENU/THUMB] button.

Returns to the normal screen.

Setting Time Code without Opening the Menu

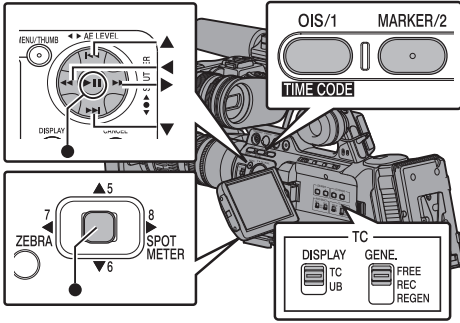

Memo : _____

- Settings cannot be made in the following cases.
 - When the [TC GENE.] switch is set to "REGEN".
 - Menu screen is displayed.
 - The camera recorder is not in the Camera mode.

Setting Time Code

- 1 Set the [TC DISPLAY] switch on the LCD monitor to "TC".
- 2 Set the [TC GENE.] switch to a setting other than "REGEN".
- 3 Hold down the [MENU/THUMB] button and press the [OIS/1] button. The [TC Preset] setting screen appears.

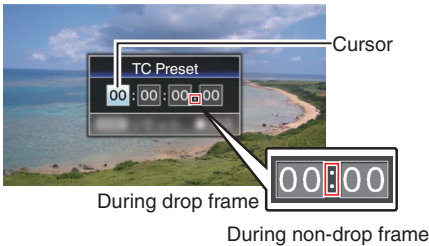

- 4 Set the time code (hour, minute, second, frame).

Use the cross-shaped button (◀▶) to place the cursor at the item to set, then use the cross-shaped button (▲▼) to change the values.

Memo : _____

- Press the [MARKER/2] button to reset each digit to "0". The cursor moves to the time digit (left).

- 5 Check the values and press the Set button (●).

- The time code is set and the screen returns to the normal screen.
- To cancel the setting, press the [CANCEL] button.

Caution : _____

- When the camera recorder is switched to Media mode during editing, editing will be canceled and the screen will close.
- When editing the time code, operation of the [OIS/1] and [MARKER/2] buttons that are set in [Main Menu] → [Camera Function] → [User Switch Set] is disabled. [MARKER/2] functions as the number reset button. (P111 [User Switch Set Item])

Recording Time Code in Continuation of the Recorded Time Code on SD Card

This camera recorder is equipped with the time code reader.

- 1 Set the [TC GENE.] switch to "REGEN".

- When the camera recorder enters from recording standby mode to recording mode, it reads the time code already recorded on the SD card and records the new time code in continuation of that value.
- The same data as the user's bit already recorded on the SD card is recorded.

Memo : _____

- When the [TC GENE.] switch is set to "REGEN", the framing mode of the time code follows the settings in [TC/UB] → [Drop Frame] instead of the clip settings. (P119 [Drop Frame])

Setting the User's Bit

You can add the date, time or an 8-digit hexadecimal number as the user's bit to the recorded image.

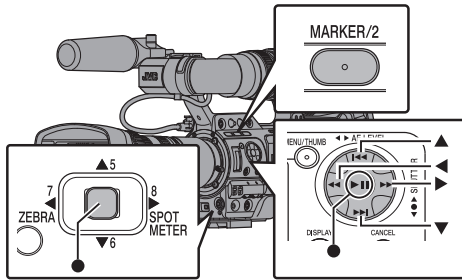

- 2 Move the cursor to [Preset] and press the Set button (●).

The [UB Preset] setting screen appears.

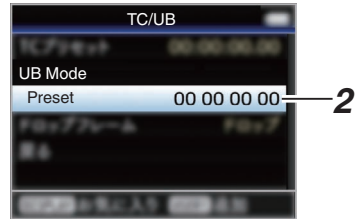

Memo : _____

- When the [TC GENE.] switch is set to "REGEN", "Regen" is displayed and preset is disabled.

Selecting a Recording Mode

Recording date/time information to the user's bit

- 1 Set [Main Menu] → [TC/UB] → [UB Mode] to "Date" or "Time", and press the Set button (●).

(☞ P119 [UB Mode])

The date or time information is recorded to the user's bit.

Memo : _____

- When "Date" or "Time" is set, [Preset] appears as "-" and cannot be set.
- "Time" is displayed in the 24-hour format.

Presetting the User's Bit

Recording arbitrary information (8-digit hexadecimal) to the user's bit

- 1 Set [Main Menu] → [TC/UB] → [UB Mode] to "SW Set", and press the Set button (●).

(☞ P119 [UB Mode])

- 3 Use the cross-shaped button (◀▶) to place the cursor at the item to set, then use the cross-shaped button (▲▼) to change the values.

Numbers between 0 and 9 or alphabets between A and F can be specified for the user's bit.

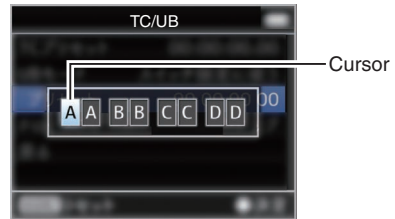

Memo : _____

- Press the [MARKER/2] button to reset each digit to "0". The cursor moves to the left.

- 4 Check the values and press the Set button (●).

- The user's bit is set and the screen returns to [TC/UB].
- To cancel the setting, press the [CANCEL] button.

- 5 Press the [MENU/THUMB] button.

Returns to the normal screen.

Setting User's Bit without Opening the Menu

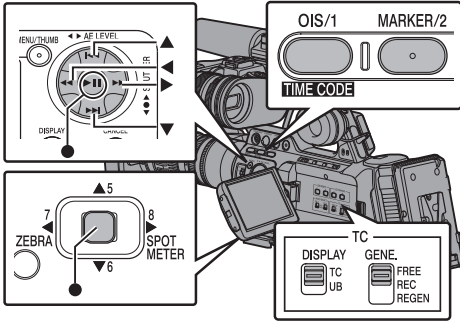

Caution : _____

- When the camera recorder is switched to Media mode during editing, editing will be canceled and the screen will close.
- When editing the user's bit, the [OIS/1] and [MARKER/2] button operations that are set in [Main Menu] → [Camera Function] → [User Switch Set] are disabled. [MARKER/2] functions as the number reset button. (P111 [User Switch Set Item])

Memo : _____

- Settings cannot be made in the following cases.
 - When the [TC GENE.] switch is set to "REGEN".
 - Menu screen is displayed.
 - The camera recorder is not in the Camera mode.

Setting the user's bit

- 1 Set the [TC DISPLAY] switch on the LCD monitor to "UB".
- 2 Set the [TC GENE.] switch to a setting other than "REGEN".
- 3 Hold down the [MENU/THUMB] button and press the [OIS/1] button.
The [UB Preset] setting screen appears.
- 4 Set the user's bit (numbers between 0 and 9, or alphabets between A and F).
Use the cross-shaped button (◀▶) to place the cursor at the item to set, then use the cross-shaped button (▲▼) to change the values.

Memo : _____

- Press the [MARKER/2] button to reset each digit to "0". The cursor moves to the time digit (left).
- 5 Check the values and press the Set button (●).
 - The user's bit is set and the screen returns to the normal screen.
 - To cancel the setting, press the [CANCEL] button.

Synchronizing the Time Code with an External Time Code Generator

This camera recorder comes with a [TC IN] terminal. Connect a time code signal generator to the [TC IN] terminal to synchronize with the SMPTE/EBU LTC time code.

Memo : _____

- After synchronization (slave lock), the internal time code generator continues to run even if there is no input from the external time code generator.

Connection

Setting up the external time code generator as a master device

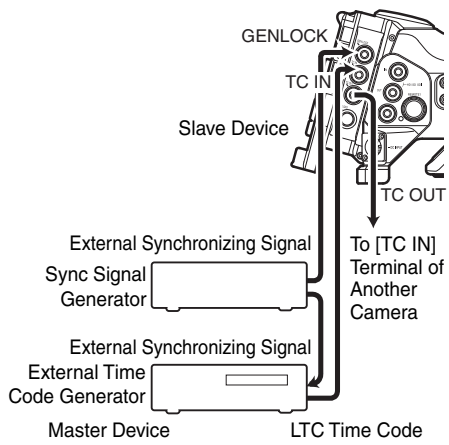

1 Input the external synchronizing signal to the external time code generator and the [GENLOCK] terminal of this camera recorder.

Memo : _____

- BB signals or HDTV tri-level synchronizing signals are used as the external synchronizing signal.
- If the power of the camera recorder is turned on/off during input of external synchronizing signals, the screen may appear disrupted for a few seconds. This is not a malfunction.

2 Input the SMPTE/EBU LTC time code from the external time code generator to the [TC IN] terminal of this camera recorder.

Connecting multiple devices, with one as the master unit and the others as slave units

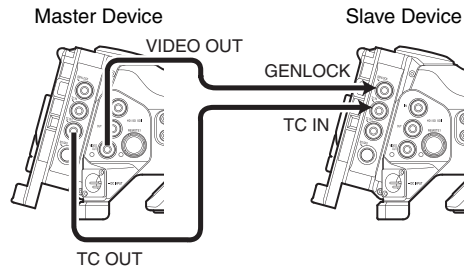

- 1 Connect the [TC OUT] terminal of the master device with the [TC IN] terminal of the slave device.
- 2 Connect the [VIDEO OUT] terminal of the master device with the [GENLOCK] terminal of the slave device.

Settings and Operation of the Camera Recorder

- 1 Set to Camera mode. (P18 [Operation Modes])
- 2 Set [A/V Set] → [Video Set] → [Genlock Input] to "BNC". (P126 [Genlock Input 890 890CH])
- 3 Set the [TC GENE.] switch to "FREE".
- 4 Set LCD monitor or viewfinder to Display 1 screen.
- 5 Set the external time code generator or the master device, and run the time code.
 - When the built-in time code generator is synchronized with the external time code data input, the icon on Display 1 screen lights up.
 - When time code is not synchronized or time code input is not available, the icon goes out.

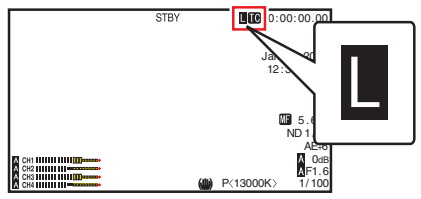

Memo : _____

- The built-in time code generator will continue operation even when the master device is disconnected after synchronization.
- User's bit will become data in the master device.
- While the [TC] terminal is connected, the time code may be out of synchronization when the [A/V Set] → [Video Set] → [HDMI/SDI Out] setting of the Master device and Slave device is being changed.
(☞ P125 [HDMI/SDI Out])

Setting Zebra Pattern

When the luminance level range for displaying zebra patterns is specified, diagonal lines (zebra pattern) are displayed at areas with the specified luminance levels during shooting.

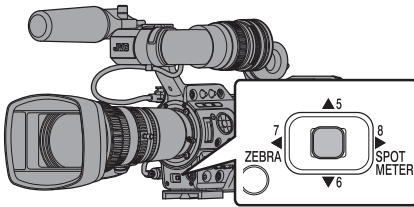

1 Set the zebra display pattern.

Select the display pattern in [LCD/VF] → [Shooting Assist] → [Zebra].
(☞ P121 [Zebra])

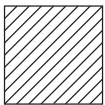

Zebra 1 Display Example

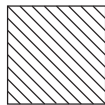

Zebra 2 Display Example

- ### 2 Specify the brightness (luminance) level range for displaying zebra pattern.
- Set the maximum brightness limit in [LCD/VF] → [Shooting Assist] → [Zebra] → [Top 1]/[Top 2], and the minimum brightness limit in [Bottom 1]/[Bottom 2].

Item	Settings	Options
Top 1	Maximum brightness limit for displaying Zebra 1	5% - 100%, Over (in 5 % increments)
Bottom 1	Minimum brightness limit for displaying Zebra 1	0% - 100% (in 5 % increments)
Top 2	Maximum brightness limit for displaying Zebra 2	5% - 100%, Over (in 5 % increments)
Bottom 2	Minimum brightness limit for displaying Zebra 2	0% - 100% (in 5 % increments)

Memo : _____

- When [Zebra] is set to "1Pattern", "Top 2" and "Bottom 2" cannot be selected.
- If the area specified by two zebra patterns overlaps, the zebra patterns will also appear overlapped, forming a grid-like display.

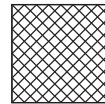

3 Display the zebra pattern.

Press the [7/◀/ZEBRA] button to display the zebra pattern in the specified range.



Memo : _____

- "Zebra" is assigned to the [7/◀/ZEBRA] buttons in the factory default.
- "Zebra" can also be assigned to other user buttons.
(☞ P42 [Assignment of Functions to User Buttons])

Setting Spot Meter

The brightness of the object during shooting is displayed.

This function is useful when setting video or stage lighting or when specifying camera exposure.

A cursor indicating the location and the brightness (%) of that location are displayed in the images shown on the LCD monitor and viewfinder screen.

- Zebra patterns display the brightness of output video signals.

(☞ P79 [Setting Zebra Pattern])

- This function allows you to check the brightness of input images from the lens without depending on image processing such as gamma curve. The dynamic range of the camera recorder is 400 % and a brightness range of 0 % to 400 % and above is displayed.

Memo : _____

- Spot meter may not be consistent with the zebra display range. When [Camera Process] → [Gamma] is set to "Cinema", the 100IRE output is not consistent with the 100 % display. When an object of more than 400 % luminance is detected, it is displayed as "400 %".

(☞ P115 [Gamma])

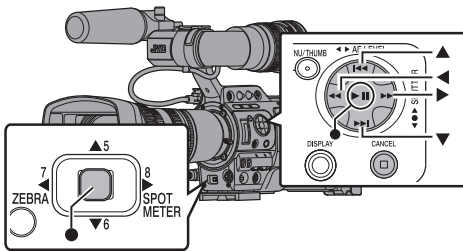

- 1 Select one of the following from [Main Menu] → [Camera Function] → [User Switch Set] → [Spot Meter].**

(☞ P111 [Spot Meter])

Item	Settings	Color of Frame Indicating the Position
Max & Min	Displays the brightness (%) and positions of the brightest and darkest areas in the screen. Frames may also be stopped at the current positions.	<ul style="list-style-type: none"> • Max: Green • Min: Yellow
Max	Displays the brightness (%) and position of the brightest area in the screen. Frames may also be stopped at the current positions.	Green
Min	Displays the brightness (%) and position of the darkest area in the screen. Frame may also be stopped at the current positions.	Yellow
Manual	Displays the brightness (%) of the specified position.	Green (Blinks in green when specifying the position)

- 2 Assign the "Spot Meter" function to any of the user buttons.**

(☞ P42 [Assignment of Functions to User Buttons])

- 3 Press the user button that is assigned with "Spot Meter".**

The operation switches as below when the button is pressed.

When [Max & Min]/[Max]/[Min] is selected

- ① The cursors appear according to the setting when the button is pressed. Green and yellow frames appear, and the brightness levels of these areas are displayed.

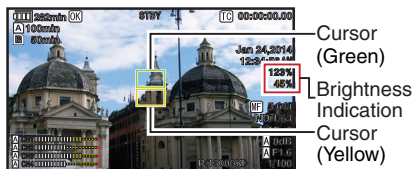

- ② Hold down the button in the state in ①, the positions of the brightest (Max) and darkest (Min) areas in the screen are automatically detected with regard to the changes of the object, and the brightness level of these areas are displayed.



- ③ Pressing the button in the state in ② stops the automatic position detection. The frames are fixed at the stopped positions and the brightness levels are displayed.
- ④ By pressing the button, the cursors and brightness indication disappear.



When [Manual] is selected

- ① The brightness of the cursor position is displayed when the button is pressed.



- ② By pressing the button, the cursors and brightness indication disappear.



- ③ Hold down the button in the state in ① or ②, the cursor blinks in green. Move the cursor with the cross-shaped button (▲▼◀▶) to specify the position to display the brightness. When you decide on the position, press the Set button (●) to confirm.



- ④ Frames are fixed at the stopped positions and the brightness is displayed.

Memo : _____

- When moving the cursor position, [Shutter]/[AE Level] control is disabled.
- When the brightness is 0 % in the entire screen, the frame is fixed in the center.
- If the cursor is outside the "4:3" range, changing [Main Menu] ⇒ [System] ⇒ [Record Set] ⇒ [Record Format] ⇒ [SD Aspect] from "16:9" to "4:3" restores the cursor to the default position. (P135 [SD Aspect])

Acquiring Positioning Information by GPS **GPS**

This camera recorder comes with a built-in GPS function. The GPS function is able to record the positioning information. During playback, you can also display the recorded information on the playback screen.
(P98 [Playing back])

1 Set [Main Menu] → [System] → [GPS] to “On”.

- Positioning starts when the icon on the display screen starts blinking.
- After positioning is complete, the icon switches to a solid light and records the positioning information during shooting.
- The icon that appears on the screen changes according to the condition of signal reception from the GPS satellite.
- The GPS function is able to record the positioning information. However, the date/time information (atomic clock) can be recorded only when [Format] is set to “AVCHD” on the slot to record to.

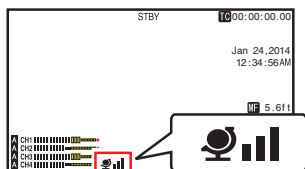

Display	Reception Status	Positioning Status
	GPS reception in progress (signal strength: strong)	Receiving strong GPS signal. UTC and positioning information can be obtained and recorded.
(No display)	GPS function is turned off	The [GPS] item is set to “Off”.

Memo :

- If positioning cannot be performed after waiting for several minutes, this means GPS reception is poor, and there is difficulty in receiving data. Move to an open place with no obstructions. Otherwise, GPS information will not be recorded when shooting is performed.
- Signal may not be received depending on circumstances such as locations that are indoors or surrounded by tall buildings, or the geographical conditions. Precision error may occur in the position information depending on the conditions of reception.
- Even when positioning is in progress, information may be disrupted depending on the condition of signal reception.
- When [GPS] is set to “Off”, and the SDI output is 1080/59.94p or 1080/50p, changing [GPS] to “On” switches the SDI output to 1080/59.94i or 1080/50i.

Display	Reception Status	Positioning Status
 (Yellow)	[GPS] is set to “On”, but signal cannot be received	GPS signal cannot be received. UTC and positioning information cannot be obtained.
 (Blink)	GPS search in progress	UTC information can be obtained, but not positioning information.
 (Weak)	GPS reception in progress (signal strength: weak)	Receiving weak GPS signal. UTC and positioning information can be obtained and recorded.
 (Medium)	GPS reception in progress (signal strength: medium)	Receiving GPS signal. UTC and positioning information can be obtained and recorded.

Viewing Recorded Videos Immediately (Clip Review)

You can check (review) the last recorded video clip on the screen.

However, the video clip cannot be played back if the settings of the camera recorder are different from the video format (Resolution/Frame & Bit Rate/SD Aspect) of the clip.

(P133 [**A** Resolution])

(P134 [**B** Resolution])

(P133 [**A** Frame & Bit Rate])

(P134 [**B** Frame & Bit Rate])

(P135 [SD Aspect])

1 Assign the “Clip Review” function to any of the user buttons.

* This excludes the [AUTO FOCUS/11] button.

(P42 [Assignment of Functions to User Buttons])

2 Press the button assigned with the “Clip Review” function during standby (“STBY” is displayed).

Playback of the configured section starts.

Memo :

- The video clip is played back according to the setting in [Main Menu] → [Camera Function] → [User Switch Set] → [Clip Review]. By default setting (Last 5sec), the last 5 seconds of the clip is played back.

(P111 [Clip Review])

- When playback is complete, the camera recorder exits Clip Review and returns to “STBY” (recording standby) mode.

Caution :

- During Clip Review, only the [CANCEL] and [REC] buttons are enabled.
Press the [CANCEL] button to cancel clip review and return to “STBY” (recording standby) mode.
Press the [REC] button to cancel clip review and enter recording mode. It will take some time to start recording after the button is pressed.
- When the last clip is less than 5 seconds, the whole clip is played back.
- Only video clips in the currently selected slot can be reviewed.
- When there are no clips in the selected slot, Clip Review function is disabled.
- Clip Review is unavailable when Clip Continuous Rec is paused (“STBY**G**”, yellow text). To operate Clip Review, use the [CANCEL] button to set to “STBY**G**” (white text) first.
(P89 [Clip Continuous Rec])
- Clip Review is unavailable when the camera recorder is connected to an external equipment and the equipment is in recording state.
- Clip Review is unavailable when operating View Remote via network connection.
(P190 [View Remote Feature])

Using the Histogram

The histogram shows the brightness distribution, and is employed mainly for checking the exposure of the image.

1 Set the histogram feature to ON.

- Set [Main Menu] → [LCD/VF] → [Display Settings] → [Histogram] to "On".
- You can also press the user button that is assigned with "Histogram".
(☞ P111 [User Switch Set Item])

2 Set the upper and lower limits of the histogram display.

After setting, the brightness level is displayed in red color.

Item	Settings	Options
Top	Sets the maximum brightness limit for changing the histogram display color	5% to 110% (in 5 % increments)
Bottom	Sets the minimum brightness limit for changing the histogram display color	0% to 105% (in 5 % increments)

■ When the upper limit is set to 110% and the lower limit to 0%



* The area in red is not displayed.

■ When the upper limit is set to 90% and the lower limit to 10%

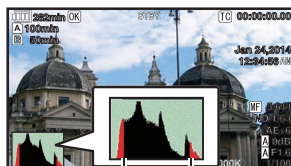

Bottom Top

How to read the histogram

- The vertical axis denotes the number of pixels.
- The horizontal axis denotes the pixel brightness.

Recording Simultaneously at Two Different Definitions

By setting [System] to "HD+SD" or "HD+Web", you can record simultaneously at two different definitions.

- When HD+SD is selected:
Records a high-definition (HD) file to slot A and a standard definition (SD) file to slot B at the same time.
- When HD+Web is selected:
Records a high-definition (HD) file to slot A and a low bit-rate web file to slot B at the same time. Web files can be used as a proxy file for the HD file.

Memo : _____

- If a recordable SD card is inserted into only one of the slots, files will only be recorded to that slot.
- The [Rec Mode] is fixed at "Normal".
- Clip Cutter Trig is disabled.
- [Slot Mode] cannot be selected.
- Clip Review can only be performed for slot A. ("No Media" appears if there is no card in slot A while a card is inserted into slot B.)
- Playback of web files is only possible from slot B when "HD+Web" is selected.

Splitting the Clips Freely (Clip Cutter Trig)

You can split the clips freely without having to stop recording during shooting.

- 1 Assign the “Clip Cutter Trig” function to any of the user buttons.
(☞ P42 [Assignment of Functions to User Buttons])
- 2 Press the user button that is assigned with “Clip Cutter Trig” during shooting.
A clip cut icon (●✂) appears on the display screen for 3 seconds, and the clip is split.

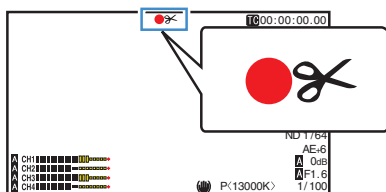

Memo : _____

- Clips cannot be split again for a few seconds after the operation is performed.
- This item cannot be used when [Slot Mode] is set to “Backup”.
- Available only when [System] is set to “HD” or “SD”.
(☞ P87 [Backup Rec])
- This item cannot be used when [Rec Mode] is set to a value other than “Normal” or “Pre Rec”.
(☞ P135 [Rec Mode])
- The split clips are recorded seamlessly without interruptions in the video.

Dual Rec

- If both the slots are loaded with recordable cards in the factory default ([Slot Mode] is set to “Series”), pressing the [REC] button starts recording only to the media in the selected slot. When the remaining space in the selected media runs out, recording continues by automatically activating the media in the other slot.
- If both the slots are loaded with recordable cards in the Dual Rec mode ([Slot Mode] is set to “Dual”), pressing the [REC] button starts recording simultaneously to the media in both the slots.
- The clips recorded to the media in both the slots are identical, and two clips of the same content can be created only on this camera recorder.
(☞ P136 [Slot Mode])

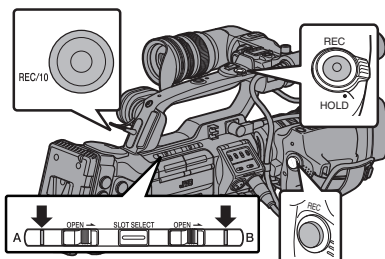

Setting to Dual Rec Mode

- 1 Set [Main Menu] → [System] → [Record Set] → [Slot Mode] to “Dual”.
(☞ P136 [Slot Mode])
“DUAL” appears on the display screen.

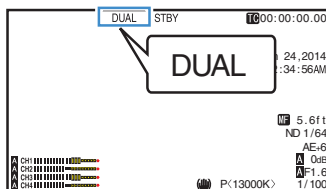

2 Start recording.

- Insert recordable media in both slots, and press the [REC] button.
- In the Dual Rec mode, recording to the media in both slots starts at the same time.
- Both the card slot marks turn red, and the status indicators of both the card slots also light up in red.

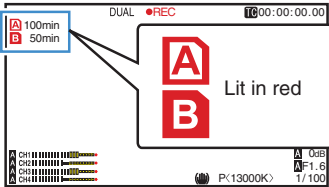

3 Stop recording.

- Press the [REC] button again.
- Recording to both slots stops, and both the card slot marks turn white.
- The same clips are recorded to both cards.

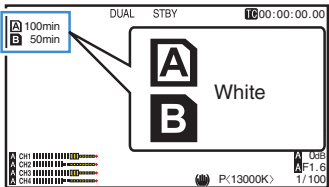

Memo :

- During recording in the Dual Rec mode, both the card slot marks light up in red.
- During recording in the Dual Rec mode to two cards with a different amount of remaining space, if the space of one card runs out, recording to both slots will stop automatically. After recording stops, recording automatically resumes for the card with remaining space. Although the clips are separated in this case, the clips can be seamlessly joined by arranging them on the timeline of the editing software since they are recorded seamlessly.
- If the last clip on the cards that are inserted in the two slots are different from each other, and the time code operating mode is set to "Regen", the Regen mode for the selected card slot will be enabled in the next recording.

Caution :

- To perform recording in the Dual Rec mode, it is recommended that you start recording by making use of two cards with the same capacity and from the formatted state.
- You can combine the use of the Dual Rec mode with a special recording mode. While in the Dual Rec mode, you can also set [Rec Mode] to "Normal", "Pre Rec", "Clip Continuous", "Interval Rec", "Frame Rec", or "Variable Frame". When [Main Menu] → [System] → [Record Set] → [Record Format] → [A]Format is set to "AVCHD", "Clip Continuous" cannot be selected. (P89 [Special Recording]) (P135 [Rec Mode]) (P133 [A Format])
- When both slots are inserted with recordable cards, the Dual Rec (simultaneous recording) operation can be performed. If a recordable media is only inserted in one of the slots, you can also start recording with one card.
- In the Dual Rec mode, continuous recording by switching from one slot to another cannot be performed. Continuous recording will not be performed if a recordable media is inserted in a slot after recording to the other slot has started.
- When recording to one slot is in progress with the recorder set to the Dual Rec mode, inserting a recordable media to the other slot does not enable the Dual Rec operation. To perform the Dual Rec operation, stop recording temporarily (excluding pausing recording in the Clip Continuous Rec mode), and start again.
- When one of the cards is accidentally removed while recording is in progress in the Dual Rec mode, recording to the card in the other slot will continue. However, repair of the accidentally removed card by the recovery function may fail.
- If an error occurs on one of the cards while recording is in progress in the Dual Rec mode, recording of the erroneous card stops, while that of the other card continues.
- Operations on clips recorded in the Dual Rec mode, such as clip deletion in the Media mode or appending of OK marks, can only be performed on the card in the selected slot.

Backup Rec

- The Backup Rec mode allows you to make use of the media in slot B for backup recording by controlling the starting and stopping of recording in slot B without using the [REC] button.
- Start or stop the recording using [Main Menu] → [System] → [Record Set] → [Slot Mode] → [Backup Rec] or press the user button that is assigned with “Backup Trig”.

(P136 [Slot Mode])

(P111 [User Switch Set Item])

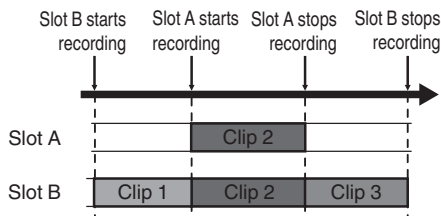

Memo : _____

- During the Backup Rec mode (when [Slot Mode] is set to “Backup”), you can control recording to the 2 slots at different timings, and backup recording can only be performed on this camera recorder.
(P136 [Slot Mode])
- You can record without worrying about missing the important scenes by setting slot B to be always recording (backup recording) and using the [REC] button to start/stop recording of only the required scenes in slot A.
- It is recommended to use a media with high capacity in slot B.

1 Set [Main Menu] → [System] → [Record Set] → [Slot Mode] to “Backup”.

(P136 [Slot Mode])

“BACKUP” appears on the display screen.

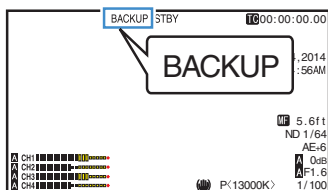

2 Start backup recording. (Backup recording into slot B)

- Select “REC” in [Main Menu] → [System] → [Record Set] → [Slot Mode] → [Backup Rec] and press the Set button (●).

(P136 [Slot Mode])

- You can also press the user button that is assigned with “Backup Trig”.

(P111 [User Switch Set Item])

- Backup recording into slot B starts. (The characters “BACKUP” appear in red.)
- The card slot mark of slot B turns red (selected state), and the status indicator of slot B also blinks in red.

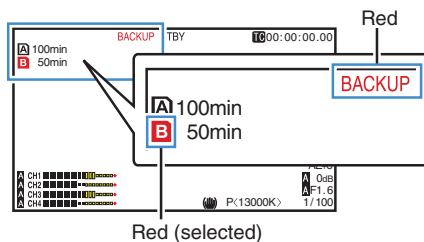

3 Start normal recording (normal recording into slot A)

- Press any of the [REC] buttons.
- Recording into the media in slot A starts. (The characters “●REC” appear in red.)
- The card icon of slot A turns red (unselected state), and the status indicator of slot A blinks in red.

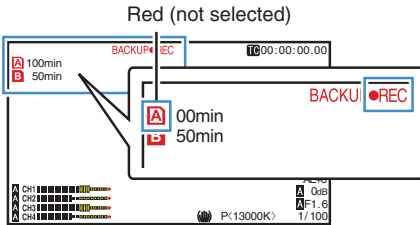

4 Stop normal recording.

- Press any of the [REC] buttons again.
- Recording to slot A stops, and the card slot mark of slot A turns white (unselected state).
- The characters “●REC” (red) changes back to “STBY” (white).
- The status indicator of slot A goes out.

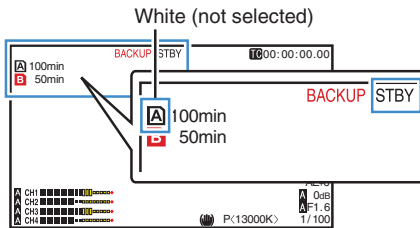

5 Stop backup recording.

- Select [STBY] in [Main Menu] → [System] → [Record Set] → [Slot Mode] → [Backup Rec] and press the Set button (●).
- (☞ P136 [Slot Mode])
- You can also press the user button that is assigned with “Backup Trig”.
- (☞ P111 [User Switch Set Item])
- Recording to slot B stops, and the card slot mark of slot B turns white (unselected state).
- The characters “BACKUP” changes back to white.
- The status indicator of slot B lights up in green.

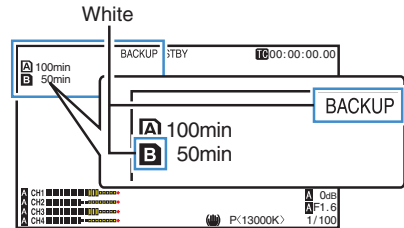

Memo : _____

- During backup recording, if the space of one card runs out, recording stops only for the card that is full.
- When recording to both slots is stopped, recording in the Regen mode will be enabled for the card slot in which recording started.
- When recording is started in the other slot while recording to one slot, the clip being recorded is split and simultaneous recording to the other card starts.
- When recording is stopped for either slot A or B while recording to both slots, the clip on the slot which is still recording is split.
- Although the clips are separated during recording the clips can be seamlessly joined by arranging them on the timeline of the editing software since they are recorded seamlessly.
- Clip Cutter Trig cannot be performed during backup recording. (☞ P85 [Splitting the Clips Freely (Clip Cutter Trig)])
- When [Slot Mode] is set to “Backup”, [Rec Mode] can only be set to “Normal”. (☞ P135 [Rec Mode])

Special Recording

Besides the normal recording mode, five special recording methods are available in this camera recorder. They are Pre Rec, Clip Continuous, Frame Rec, Interval Rec and Variable Frame. Select a mode from [Record Set] → [Rec Mode].

Memo : _____

- Set using [Main Menu] → [System] → [Record Set] → [Rec Mode].
(P135 [Rec Mode])
- When [Main Menu] → [System] → [Record Set] → [Record Format] → [A Format] is set to "AVCHD", "Clip Continuous" cannot be selected.
(P133 [A Format])

Pre Rec

- By setting the number of seconds in the [Pre Rec Time], you can start recording video and audio before actual recording starts based on the [Pre Rec Time] setting.
- When starting actual recording while the camera recorder is in Recording Standby (STBY \square) mode, you can start recording a few seconds earlier based on the [Pre Rec Time] setting.
- Using Pre Rec allows you to record a complete event without missing the initial scenes even if you start the recording late.

Memo : _____

- Pre Rec time can be set to "5sec" or "10sec" in [Main Menu] → [System] → [Record Set] → [Rec Mode] → [Pre Rec Time].
(P135 [Pre Rec Time])

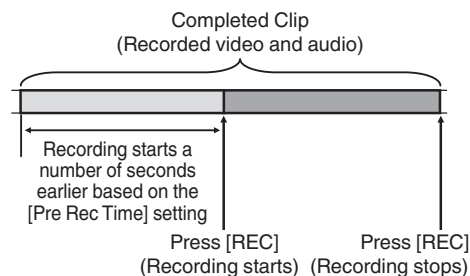

1 Set [Rec Mode] to "Pre Rec".

(P135 [Rec Mode])

- Set [Main Menu] → [System] → [Record Set] → [Rec Mode] to "Pre Rec".
- The display changes ("STBY" → "STBY \square ").

2 Press the [REC] button to start recording in Pre Rec mode.

- The display changes ("STBY \square " → "●REC \square ") and the card slot status indicator lights up in red.
- Press the [REC] button again to pause recording. The display changes ("●REC \square " → "STBY \square ") and the card slot status indicator lights up in green.

Caution : _____

- When the interval between start and stop recording is short, "STBY \square " may not be displayed immediately after recording is complete.
"●REC \square " → "STBY \square " ("STBY" blinks in red) → "STBY \square " is displayed.
- When the SD card becomes full during recording, recording stops and "STOP" is displayed.
- Video and audio before the above mentioned time may not be recorded after recording starts in the following cases.
 - Immediately after power on
 - Immediately after recording stops
 - Immediately after switching from Media mode to Camera mode
 - Immediately after setting [Rec Mode]
 - Immediately after the end of Clip Review
 - Immediately after changing file format
 - Immediately after changing video format

Clip Continuous Rec

- In normal recording, when the recording stops, the image, audio, and accompanying data from the start till the end of the recording are recorded as one "clip" on the SD card.
- This mode allows you to consolidate several rounds of "startstop recording" into one clip.

Example:

In normal recording, three clips are generated as Recording 1, Recording 2, and Recording 3. However, recording in this mode generates only one clip.

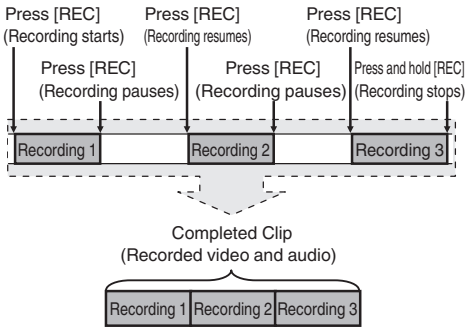

1 Set “Rec Mode” to “Clip Continuous”.

(☞ P135 [Rec Mode])

- Set [Main Menu] → [System] → [Record Set] → [Rec Mode] to “Clip Continuous”.
- The display changes (“STBY” → “STBY \square ”).

2 Start recording. (Recording 1)

- Press the [REC] button to start recording in Clip Continuous mode.
- The display changes (“STBY \square ” → “●REC \square ”) and the card slot status indicator lights up in red.

3 Pause recording.

- Press the [REC] button again to pause recording. The display changes (“●REC \square ” → “STBY \square ” (yellow text)).
- The card slot status indicator remains lighted in red.

Memo : _____

- When the [CANCEL] button is pressed while the camera recorder is paused (STBY \square), the display changes (“STBY \square ” (yellow text) → “STBY \square ” (blinking yellow text) → “STBY \square ” (white text)), and a “clip” is generated. The card slot status indicator lights up in green.

4 Resume recording. (Recording 2)

- Press the [REC] button again to resume recording. The display changes (“STBY \square ” (yellow text) → “●REC \square ”).
- The card slot status indicator remains lighted in red.

5 Pause recording.

- Press the [REC] button again to pause recording. The display changes (“●REC \square ” → “STBY \square ” (yellow text)).
- The card slot status indicator remains lighted in red.

6 Resume recording. (Recording 3)

- Press the [REC] button again to resume recording. The display changes (“STBY \square ” (yellow text) → “●REC \square ”).
- The card slot status indicator remains lighted in red.

7 Press and hold the [REC] button.

- Recording stops and the display changes (“●REC \square ” → “STBY \square ”). A “clip” is generated.
- The card slot status indicator lights up in green.

8 Press the [REC] button again.

- The display changes (“STBY \square ” → “●REC \square ”) and the card slot status indicator lights up in red.
- A new “clip” is generated from here.

Memo : _____

- The following operations cannot be performed while recording is paused (STBY \square , yellow text).
 - Clip Review operation (☞ P83 [Viewing Recorded Videos Immediately (Clip Review)])
 - Switching SD card slots
 - Switching operation mode (☞ P18 [Operation Modes])

Caution : _____

- Do not remove the SD card during recording (●REC \square , red text) or recording pause (STBY \square , yellow text).
- To remove the SD card in the “Clip Continuous” mode, press the [CANCEL] button, check that “STBY \square ” (white text) is displayed and the card slot status indicator lights up in green before you remove the card.
- When the SD card becomes full during recording, recording stops and “STOP” is displayed.
- When the [POWER ON/OFF] switch is turned off during recording or recording pause, recording stops and power is cut off after a clip is generated.

Caution : _____

- If the power is cut off due to low battery power, a proper clip may not be generated.
- When [A Format]/[B Format] in the [Main Menu] → [System] → [Record Set] → [Record Format] menu is set to "AVCHD", Clip Continuous Rec cannot be performed.
(☞ P133 [A Format])
(☞ P134 [B Format])

Frame Rec

In normal recording, when the recording stops, the image and accompanying data from the start till the end of the recording are recorded as one "clip" on the SD card.

In this mode, recording starts with every press of the [REC] button, and only the specified number of frames is recorded.

The recording can be written to the media as a single clip until it is stopped.

Memo : _____

- Audio will not be recorded.
- Until a specified amount of recordings is accumulated, the file cannot be written to the media.
- If the specified amount is not reached when recording is stopped, normal recording is performed and frames are added to the ending of the clip until the amount is reached. (Padding)
- After the specified number of frames is recorded and written to the media, recording will be performed until the same number is accumulated again.

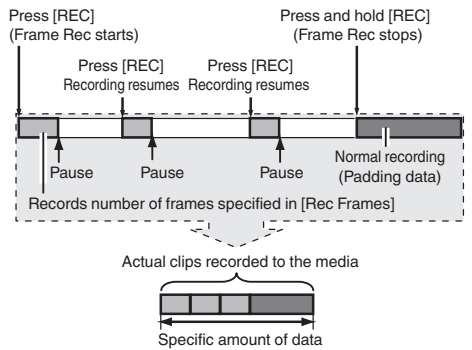

- 1 Set [Rec Mode] to "Frame Rec".**
 - Set [Main Menu] → [System] → [Record Set] → [Rec Mode] to "Frame Rec".
(☞ P135 [Rec Mode])
 - The display changes ("STBY" → "STBY").
- 2 Set the number of frames to record in [Rec Frames].**
 - Set using [Main Menu] → [System] → [Record Set] → [Rec Mode] → [Rec Frames].
(☞ P135 [Rec Frames])
- 3 Start recording.**
 - Press the [REC] button to record only the number of frames specified in [Rec Frames] and pause.
 - The display changes ("STBY" → "●REC" → "STBY" (yellow text)).
 - The card slot status indicator lights up in green.
- 4 Repeat Frame Rec.**
 - Press the [REC] button again to record only the number of frames specified in [Rec Frames] and pause.
 - The display changes ("STBY" → "●REC" → "STBY" (yellow text)).
 - Frame Rec continues until the recording is stopped (step 5).
- 5 Press and hold the [REC] button.**
 - The card slot status indicator lights up in green.

Caution : _____

- Do not remove the SD card during recording ("●REC", red text) or recording pause ("STBY", yellow text).
- To remove the SD card during Frame Rec, press the [CANCEL] button, check that "STBY" (white text) is displayed and the card slot status indicator lights up in green before you remove the card.
- When the [TC GENE.] switch inside the door of the LCD monitor is set to "FREE", the time code is recorded in the "Rec Run" mode.
- Audio cannot be recorded. The audio level meter is grayed out.
(☞ P147 [Audio Level Meter])

Variable Frame Rec

Shooting in this mode allows you to obtain smooth slow motion or quick motion videos.

Using different frame rate settings for recording and playback, videos captured at normal speed can be played back more smoothly than those in low or high speed playback.

The ability to change the frame rate during recording enables quick to gradually slow motion effects.

To enable Variable Frame Rec, the following settings are required.

- [Record Format] → [System] has been set to “HD”.
- [Record Format] → [A]Resolution] is set to “1920x1080” or “1280x720”.
- The frame rate in [Record Format] → [A]Frame & Bit Rate] is set to “30p”, “25p”, or “24p”.

1 Set the various items in [Record Format].

(P132 [Record Format])

2 Set [Rec Mode] to “Variable Frame”.

(P135 [Rec Mode])

Set [Main Menu] → [System] → [Record Set] → [Rec Mode] to “Variable Frame”.

3 Set a [Variable Frame Rate].

(P135 [Variable Frame Rate])

Select a recording frame rate in [Main Menu] → [System] → [Record Set] → [Rec Mode] → [Variable Frame Rate].

The selectable frame rates are as shown in the table below.

Memo :

- When [Main Menu] → [Camera Function] → [AE LEVEL SW] is set to “AE LEVEL/VFR”, you can use the cross-shaped button (◀▶) to select the frame rate during Variable Frame Rec. In modes other than Variable Frame Rec, the cross-shaped button (◀▶) functions as the AE level setting button.
(P109 [AE Level])
- If the specified amount is not reached when recording is stopped, normal recording is performed and frames are added to the ending of the clip until the amount is reached. (Padding)

Caution :

- When the [TC GENE.] switch inside the door of the LCD monitor is set to “FREE”, the time code is recorded in the “Rec Run” mode.
- Audio cannot be recorded. The audio level meter is grayed out.
(P147 [Audio Level Meter])

[A]Resolution]	Frame Rate of [A]Frame & Bit Rate]	Selectable Shooting Frame Rate		
1920x1080 (*1)	30p	-	30	27, 25, 24, 22.5, 20, 18, 15, 12, 10, 6, 2
	24p	30, 27, 25	24	22.5, 20, 18, 15, 12, 10, 6, 2
	25p	-	25	24, 22.5, 20, 18, 12.5, 10, 6, 2
1920x1080 (*2) 1280x720 (*3)	30p	60, 54, 50, 48, 45, 40, 36, 32	30	27, 25, 24, 22.5, 20, 18, 15, 12, 10, 6, 2
	24p	60, 54, 50, 48, 45, 40, 36, 32, 30, 27, 25	24	22.5, 20, 18, 15, 12, 10, 6, 2
	25p	50, 48, 45, 40, 36, 32	25	24, 22.5, 20, 18, 12.5, 10, 6, 2
Effect during playback		Slow motion	Standard	Quick motion

*1 When [A]Format] is set to MP4 (MPEG2), QuickTime (MPEG2) or MXF (MPEG2)

*2 When [A]Format] is set to QuickTime (H.264)

*3 When [A]Format] is set to MP4 (MPEG2) or QuickTime (MPEG2)

Playing Recorded Clips

To play back clips recorded on SD cards, switch to the Media mode.

Press and hold the [CAM/MEDIA] selection button in the Camera mode to enter the Media mode. A thumbnail screen of the clips recorded on the SD card is displayed.

You can play back the selected clip on the thumbnail screen.

Memo : _____

- When an SD card without any clips is inserted, "No Clips" is displayed.

Operation Buttons

Use the operation buttons, on the side control panel of the camera recorder or the LCD monitor, to operate the thumbnail screen.

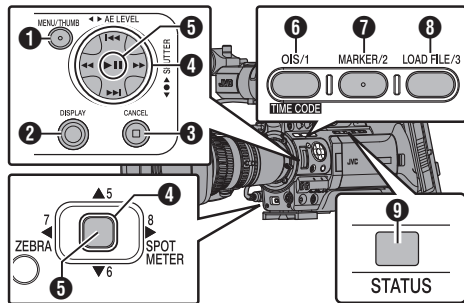

- [MENU/THUMB] Button**
 - Displays the menu.
 - Press this button to close the menu screen during menu display and return to the thumbnail screen.
- [DISPLAY] Button**

Switches between the "Standard Screen" and "Detailed Screen".
- [CANCEL] (Stop) Button**

Cancels settings and returns to the previous screen.
- Cross-Shaped Button (▲▼◀▶)**

Moves the cursor.
- Set (Play) Button**
 - Sets the values and items. (Confirm)
 - Plays back the selected clip.
- [OIS/1] Button**
 - Switches the OK mark of the clip selected by the cursor.
 - If an OK mark has been appended, it will be deleted. Otherwise, an OK mark will be appended.

- [MARKER/2] Button**
 - Switches the selection status of the clip selected by the cursor.
 - Clips being selected are displayed with check mark.

- [LOAD FILE/3] Button**

Enters the action selection screen.

- [STATUS] Button**

Displays the media information screen.

Thumbnail Screen

- "Standard Screen" and "Detailed Screen" are available. Use the [DISPLAY] button to switch between the screens.
- Thumbnails are displayed in order of recording from the oldest to most recent.

Standard screen

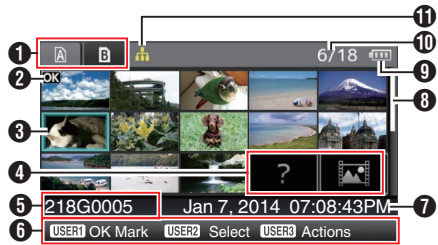

- SD Card Information**
 - Displays the status of the inserted SD card, selected SD card, write-protect switch, and the need for restoring.
 - Use the [SLOT SELECT] button to switch the slot. Clips in slot A and B cannot be displayed at the same time.

A : Write-protect switch of the SD card in slot A is set.

B! : SD card in slot B needs to be restored or formatted, or is an unsupported SD card.

- Clip Mark**

Displays the clip information (properties).



- OK Mark**

Clip is appended with OK mark.

Memo : _____

- Clips appended with OK marks cannot be deleted on the camera recorder.
- When [Main Menu] → [System] → [Record Set] → [Record Format] → [A Format] is set to “AVCHD”, the OK mark indicates that the clip is protected.
(☞ P133 [A Format])

② Continued From Mark

This mark indicates that the current clip is continued from another SD card when recording is divided and made on several SD cards.

③ Uneditable Mark

- This mark indicates that an OK mark cannot be appended to or deleted from the clip, and the clip cannot be deleted.
- When [Main Menu] → [System] → [Record Set] → [Record Format] → [Format] is set to “AVCHD”, clips that are not recorded on this camera recorder cannot be edited.
- When [Main Menu] → [System] → [Record Set] → [Record Format] → [A Format] is set to “AVCHD”, clips that are not recorded on this camera recorder cannot be edited.

④ Continue Mark

This mark indicates that the current clip is continued onto another SD card when recording is divided and made on several SD cards.

⑤ Check Mark

- A green check mark is displayed when the clip is selected.
- Magenta and gray check marks are displayed in multiple selection mode.
(☞ P100 [Selecting and Performing Operations on Multiple Clips])

③ Cursor

Clip to be worked on. Use the cross-shaped button (▲▼◀▶) to move the cursor.

④ Thumbnail Substitution Display



- ① A clip with corrupted management information. It cannot be played back even if you press the Set (Play) button.
- ② A clip that cannot be played back nor displayed in thumbnail with the current video format settings. It cannot be played back even if you press the Set (Play) button.

Memo : _____

- Dependent on the settings for [Main Menu] → [System] → [Record Set] → [Record Format] → [System], [A Resolution]/[B Resolution], and [A Frame & Bit Rate]/[B Frame & Bit Rate].
(☞ P132 [System])
(☞ P133 [A Frame & Bit Rate])
- When [Record Format] → [A Format] is set to “AVCHD”, playback may fail if the files are recorded on camera recorders other than the GY-HM890, GY-HM850, GY-HM650 and GY-HM600 series.
If a file cannot be played back, the above thumbnail substitution display ② is displayed.

⑤ Clip Name

The file name (clip number) of the selected clip is displayed.

⑥ Operation Guide

- Displays a guide for the current operation buttons.
- The action selection screen is displayed when the User 3 ([LOAD FILE/3]) button is pressed.
(☞ P96 [Actions])

⑦ Recording Start Time

Displays the recording start time of the clip.

Memo : _____

- The date/time display is dependent on the [LCD/ VF] → [Display Settings] → [Date Style]/[Time Style] settings in the [Main Menu] screen.
(☞ P124 [Date Style])
(☞ P124 [Time Style])

⑧ Scroll Bar

- Indicates the scroll position.
- Black space below the scroll bar (white) indicates that there are more pages.
- When the scroll bar (white) is at the bottom, this indicates the last page.

⑨ Remaining Battery Power

(☞ P32 [Power Status Display])

⑩ Number of Clips

- If none of the clips are selected, the “running number/total number of clips” of the clip to be displayed appears.
- Even if only one clip is selected, the number of selected clips in the current slot is displayed.

⑪ Network Connection Icon

- When [Main Menu] → [System] → [Network] is set to “On(SDI Off)” or “On(HDMI Off)”, the network connection status is displayed. This icon is not displayed when “Off” is selected.
(☞ P149 [Network Connection Icon])

Detailed screen

* Items that are common with the Standard screen will not be described. Refer to “[Standard screen] (P 94)”.

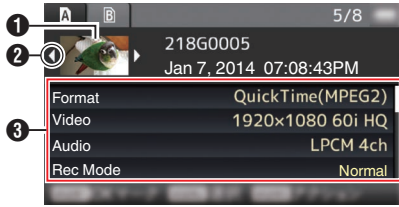

- 1 **Thumbnail**
Thumbnail of the clip selected by the cursor. Use the cross-shaped button (◀▶) to move the cursor.
- 2 **Scroll Mark (◀▶)**
 - If there are previous clips, ◀ appears on the left.
 - If there are more clips, ▶ appears on the right.
 - The marks will not be displayed if there are no clips before and after the current clip.
- 3 **Metadata**
Metadata of the clip pointed by the cursor. You can use the cross-shaped button (▲▼) to scroll.

Actions

The action selection screen is displayed when the User 3 ([LOAD FILE/3]) button is pressed.

The following operations can be performed.

Item	Description
Select All Clips	Selects all clips.
Select OK Marked	Selects all clips appended with OK mark.
Select Range	Specifies the range when selecting multiple clips. (P101 [Selecting Multiple Clips Consecutively])
Deselect All	Clears all clip selections.
Add OK Mark	Appends an OK mark. <ul style="list-style-type: none"> • This Clip: Appends an OK mark to the clip pointed by the cursor. • Selected Clips: Appends an OK mark to the clips selected (appended with check mark). • All Clips: Appends an OK mark to all clips.
Delete OK Mark	Deletes the OK mark. <ul style="list-style-type: none"> • This Clip: Deletes the OK mark of the clip pointed by the cursor. • Selected Clips: Deletes the OK mark of the clips selected (appended with check mark). • All Clips: Deletes the OK mark of all clips.

Item	Description
FTP Upload	Uploads a clip to the FTP server. <ul style="list-style-type: none"> • This Clip: Uploads the clip pointed by the cursor. • Selected Clips: Uploads the clips selected (appended with check mark). • All Clips: Uploads all clips.
Delete Clips	Deletes clip. However, clips with OK mark cannot be deleted. <ul style="list-style-type: none"> • This Clip: Deletes the clip pointed by the cursor. • Selected Clips: Deletes the clips selected (appended with check mark). • All Clips: Deletes all clips.
Trim This Clip	Trims the clip pointed by the cursor.

Memo :

- The object of action is the clip of the current slot being displayed.
- [Selected Clips] cannot be performed if there are no selected (appended with check mark) clips.
- [This Clip] cannot be performed if there are more than one selected (appended with check mark) clips.
- If the write-protect switch of an SD card is set, OK mark cannot be appended or deleted, and the clips cannot be deleted.

Playing back

Use the operation buttons on the side control panel of the camera recorder to play back.

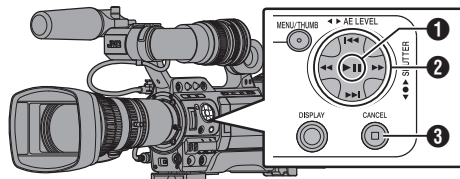

1 Button

- Plays back/pauses the clip pointed by the cursor.
- You can press the cross-shaped button () to perform frame-by-frame forward playback during pause mode.

2 Button

Skips in the reverse or forward direction.

Button

During Playback:

Fast forwards in the reverse or forward direction.

While paused:

Frame-by-frame playback in the reverse or forward direction.

3 Button

Stops playback.

1 In the thumbnail screen, move the cursor to the clip to be played back.

Move the cursor to the clip to be played back using the cross-shaped button ()

2 Press the playback/pause button.

Playback of the selected clip starts.

Audio Output during Playback

- You can check the playback sound from the monitor speaker or the earphone connected to the [PHONES] terminal. When an earphone is connected to the [PHONES] terminal, sound cannot be output from the monitor speaker. (P163 [Connecting a Earphone])
- Adjust the volume of the monitor speaker and earphone using the [MONITOR +/-] volume adjustment button on the LCD monitor of the camera recorder.

Time Code Playback

Time code or user's bit recorded on an SD card can be displayed on the LCD monitor and viewfinder.

Memo : _____

- The time code is also superimposed on the video signal output from the [HD/SD SDI] output terminal.
- User's bit output from the [HD/SD SDI] output terminal is used as a flag to determine valid video signals. Therefore, accurate values will not be output.
- If a section without time code is played back, the time code will stop. However, playback will continue.

Displaying Information during Shooting

Pressing the [DISPLAY] button during playback displays the display screen.

Pressing the [F.ASSIST/4] button each time changes the shooting information displayed (not displayed, camera information display, GPS display).

- The GPS display displays information on the recording location of the video being played back only when GPS information has been recorded. The local date/time is displayed.
- Camera information display displays only information of Gain, Iris, Shutter and White Balance that have been recorded.

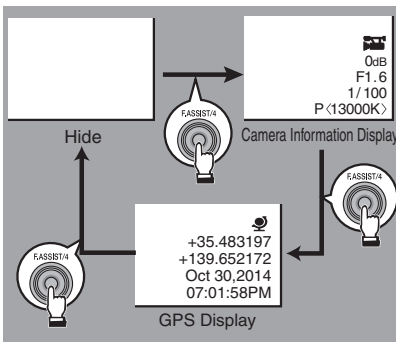

Memo : _____

- GPS function (recording of GPS information) is available only on models with built-in GPS. **GPS** Models without built-in GPS (GY-HM890RE/GY-HM890RCHE/GY-HM850RE/GY-HM850RCHE) can only provide the information display of the video with the recorded GPS information.

- When [System] → [Record Set] → [Record Format] → System is set to “HD+SD” or “HD+Web”, only SD or web files can be played back from slot B. In this case, files up-converted into the HD size are played back in the simple mode.
- Trimming information is displayed while trimming is in progress. In this case, pressing the [F.ASSIST/4] button does not switch the display.

Deleting Clips

Delete clip.

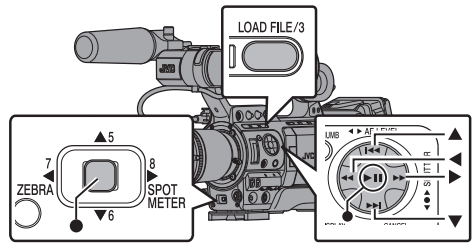

Memo : _____

- Clips appended with OK marks cannot be deleted on the camera recorder.
- Read-only clips can be deleted on a PC.

Deleting One Clip

Delete the clip (one clip) pointed by the cursor in [Delete Clips] → [This Clip] in the menu.

Memo : _____

- Clips with OK mark cannot be deleted.

During Thumbnail Screen

- 1 **Move the cursor to the clip to be deleted.** Move the cursor to the clip to be deleted using the cross-shaped button (▲▼◀▶).

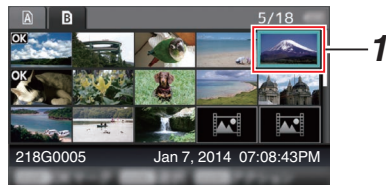

- 2 **Press the [LOAD FILE/3] button.** The action selection screen is displayed.

- 3 Select [Delete Clips] → [This Clip] and press the Set button (●).

A screen to confirm deletion appears.

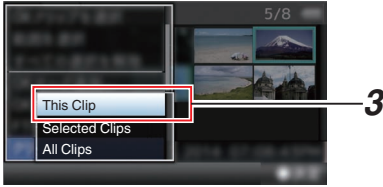

- 4 Select [Delete] using the cross-shaped button (▲▼), and press the Set button (●). Deleting starts.

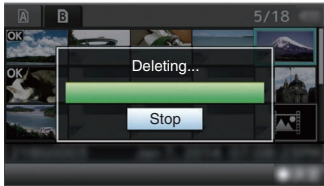
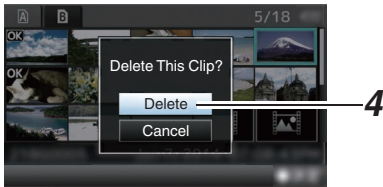

Selecting and Deleting Multiple Clips

To select and delete multiple clips, refer to “[Selecting and Performing Operations on Multiple Clips] (P 100)”.

Deleting All Clips

Delete all clips that are displayed.

- 1 Press the [LOAD FILE/3] button.
The action selection screen is displayed.
- 2 Select [Delete Clips] → [All Clips].
A screen to confirm deletion appears.
- 3 Select [Delete] and press the Set button (●).
Deleting starts.

Memo : _____

- The time taken to delete clips depends on the number of clips to be deleted.

Appending/Deleting OK Mark

- You can append OK marks to the clips for important scenes.
- Clips appended with OK marks cannot be deleted, thus protecting the important clips.
- When the camera recorder is in Media mode, you can delete the OK marks appended during recording, or append/delete OK marks after shooting.

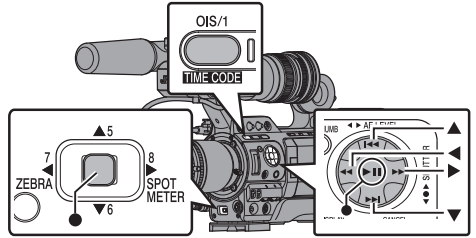

Playback

During Thumbnail Screen

- 1 Press the [OIS/1] button.
 - If the clip does not have an OK mark, an OK mark will be appended.
 - If the clip is appended with an OK mark, the OK mark will be deleted.

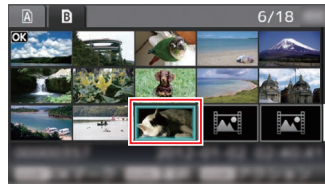

During Playback or Pause Screen

- 1 Press [OK/1] button during clip playback.
 - If the clip does not have an OK mark, an OK mark will be appended.
 - If the clip is appended with an OK mark, the OK mark will be deleted.



Memo : _____

- The clip pauses when an OK mark is appended or deleted during playback.

Appending/Deleting OK Mark of Multiple Clips

To select and append/delete OK mark for multiple clips, refer to “[Selecting and Performing Operations on Multiple Clips] (P 100)”.

Selecting and Performing Operations on Multiple Clips

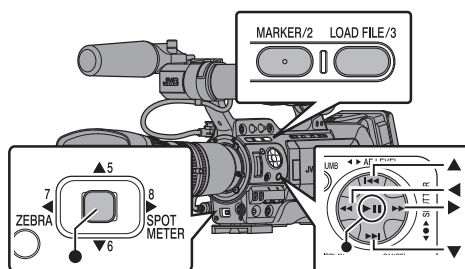

- Multiple clips can be selected during thumbnail screen or playback screen display.
- After selecting multiple clips, perform appending/deleting of OK mark, deleting of clips using the action selection screen.
- After selecting multiple clips, the selections will be canceled by the following operations.
 - When [Deselect All] in the action menu is selected
 - When exiting Media mode from the thumbnail screen
 - When removing the SD card
 - When switching the slot in use

Selecting Multiple Clips Randomly

- 1 Move the cursor to a clip without a check mark, and press the [MARKER/2] button. A green check mark appears on the clip.

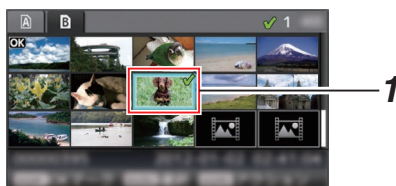

- 2 Repeat Step 1 to select multiple clips.**
- Multiple clips can be selected.
 - Press the [LOAD FILE/3] button while the multiple clips are selected.
 - Appends OK mark together: [Add OK Mark] → [Selected Clips]
 - Deletes OK mark together: [Delete OK Mark] → [Selected Clips]
 - Uploading selected clips to the FTP server together: [FTP Upload] → [Selected Clips]
 - Deletes selected clips together: [Delete Clips] → [Selected Clips]

Memo : _____

- Selecting clips appended with check mark and pressing the [MARKER/2] button will cancel the selection.
- If the operation is performed on multiple clips at the same time, a progress bar appears. You can stop the operation by pressing the Set button (●) while the operation is in progress. However, it is not possible to undo operations that are completed.

Selecting Multiple Clips Consecutively

- 1 Press the [LOAD FILE/3] button.
- 2 Select "Select Range" in the action selection screen, and press the Set button (●).

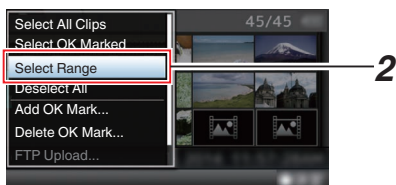

- 3 Move the cursor to the beginning (or end) of the range for multiple selection, and press the Set button (●).

- 4 Move the cursor to the other end of the range.
 - Magenta check marks appear on the clips within the range. (Including clips that were already selected.)
 - Gray check marks appear on selected clips that are outside the range.

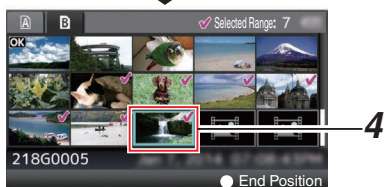
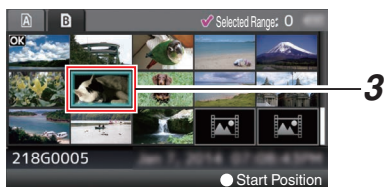

- 5 Press the Set button (●) to confirm the range.
 - The check marks change from magenta to green.
 - Pressing the [LOAD FILE/3] button while the multiple clips are selected displays the action selection screen. The following operations can be performed.
 - Appends OK mark together: [Add OK Mark] → [Selected Clips]
 - Deletes OK mark together: [Delete OK Mark] → [Selected Clips]
 - Uploading selected clips to the FTP server together: [FTP Upload] → [Selected Clips]
 - Deletes selected clips together: [Delete Clips] → [Selected Clips]

Memo : _____

- Selecting clips appended with check mark and pressing the [MARKER/2] button will cancel the selection.
- If the operation is performed on multiple clips at the same time, a progress bar appears. You can stop the operation by pressing the Set button (●) while the operation is in progress. However, it is not possible to undo operations that are completed.

Trimming Recorded Clips

You can extract (trim) the necessary parts of a clip recorded in the SD card.
The trimmed clip is saved as a new file on the same SD card as the original clip. No changes are made to the original clip.

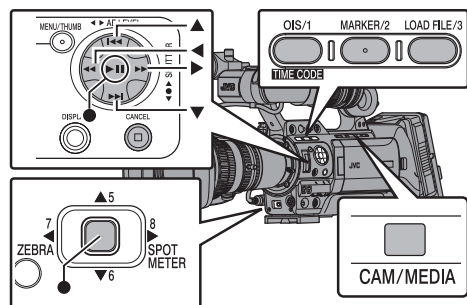

- 1 **Switch to Media mode.**
Switch the mode using the [CAM/MEDIA] selection button on the side operation panel.
- 2 **Move the cursor to the clip to be trimmed.**
Move the cursor to the clip to be trimmed using the cross-shaped button (▲▼◀▶).

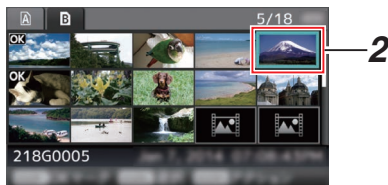

- 3 **Press the [LOAD FILE/3] button.**
The action selection screen is displayed.

- 4 **Select [Trim This Clip], and press the Set button (●).**
Playback of the selected clip starts.

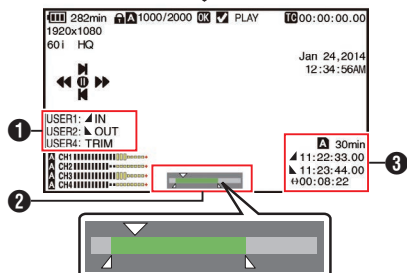
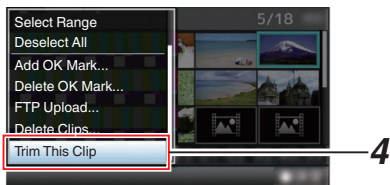

- 1 **Guide**
Operation guide
- 2 **Position bar**
▼ : Current position of the video
▲ : Position to start trimming (in point)
▶ : Position to end trimming (out point)
- 3 **Trimming information**
A or B : Indicates the available space in the storage media (A or B)
▲ : Indicates the time code of the in point
▶ : Indicates the time code of the out point
↔ : Indicates the duration from the in point to the out point

Memo : _____

- The trimmed clip will be saved to the same card slot as that of the original clip.
- [Duration] appears in yellow if the duration is 10 minutes or longer. Trimming cannot be performed in this case.
- [Duration] appears in yellow if the duration is longer than the recordable time on the storage media. Trimming cannot be performed in this case.
- When trimming starts, the display switches to the Media Display 2 screen.

5 Specify the in point.

- Operate buttons such as ◀◀/▶▶ or ◀◀/▶▶ to move the video to the in point. (P97 [Playing back])
- Specify the in point by pressing the [OIS/1] button at the point you want to start trimming.

6 Specify the out point.

- Operate buttons such as ◀◀/▶▶ or ◀◀/▶▶ to move the video to the out point. (P97 [Playing back])
- Specify the out point by pressing the [MARKER/2] button at the point you want to end trimming.

7 Perform trimming.

Press the [LOAD FILE/3] button to perform trimming.

Memo : _____

- While trimming is in progress, you can press the [CANCEL] button to return to the thumbnail screen.
- While trimming is in progress, you can press the [DISPLAY] button to switch the display, but the trimming information is displayed at all times.
- When trimming the in and out point, the in point trimmed may be up to one second before the specified in point and the out point trimmed may be up to one second behind the specified out point.

Basic Operations in Menu Screen

- Press the [MENU/THUMB] button on the side control panel of the camera recorder or on the LCD monitor to display the menu screen on the LCD monitor and viewfinder.
- Various settings for shooting and playback can be configured on the menu screen.
- There are two types of menu screens - [Main Menu] and [Favorites Menu].
- [Main Menu] contains all the setting items of the camera recorder, classified according to functions and uses, while [Favorites Menu] allows users to customize the menu items freely. (P142 [Adding/Editing Frequently Used Menu Items])
- The operating procedures and main screen displays are the same for both menus.
- The menu screen can also be displayed on external monitors connected to the video signal output terminal. (P126 [HDMI Out Character]) (P126 [SDI Out Character]) (P126 [VIDEO Out Character])

Operation Buttons

To operate the menu, use the cross-shaped buttons on the side operation panel of the camera recorder or the cross-shaped buttons at the front of the camera or at the bottom of the lens.

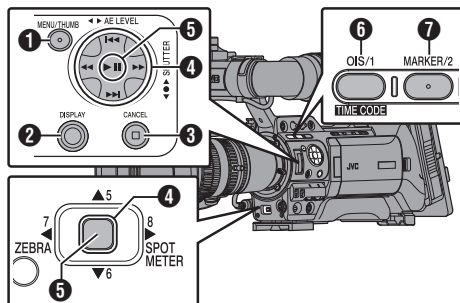

- 1 [MENU/THUMB] Button
 - Displays the menu screen. The [Main Menu] screen is displayed by default.
 - During normal usage, [Main Menu] is displayed if the previous menu operation ended at [Main Menu], and [Favorites Menu] if the previous menu operation ended at [Favorites Menu].
 - Press this button to close the menu screen during menu display and return to the normal screen.
 - Pressing and holding down the button while the menu is displayed switches the [Main Menu] screen to the [Favorites Menu] or vice versa.
- 2 [DISPLAY] Button

Switches between the [Main Menu] and [Favorites Menu] screens.
- 3 [CANCEL] Button

Cancels settings and returns to the previous screen.
- 4 Cross-shaped Button (▲▼◀▶)
 - ▲ : Moves the cursor upward.
 - ▼ : Moves the cursor downward.
 - ◀ : Moves back to the previous item.
 - ▶ : Moves forward to the next item.
- 5 Set Button (●)

Sets the values and items.
- 6 [OIS/1] Button

Adds the selected menu or submenu item to the [Favorites Menu].
(P142 [Adding/Editing Frequently Used Menu Items])
- 7 [MARKER/2] Button

Resets settings in the [TC Preset] or [UB Preset] setting screen. This button is disabled in other screens.

Display and Description of the Menu Screen

Selecting Menu Items

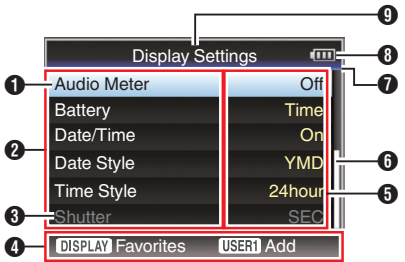

- 1 Cursor

Indicates the selected item. Use the cross-shaped button (▲▼) to move the cursor
- 2 Menu Item
 - Displays the names of the menu item and sub-menu.
 - Menu items with [...] after them indicates that there is a sub-menu to access.
- 3 Fixed Item

Items that cannot be changed are displayed in gray and cannot be selected.
- 4 Operation Guide

Guide for the current operation buttons.
- 5 Setting Value

Setting values for the menu items. For menus with sub-menus, values are not displayed.
- 6 Scroll Bar

Indicates the scroll position.
- 7 Header

Indicates the current menu type with the line color.

 - Blue : [Main Menu] Screen
 - Green : [Favorites Menu] (Operation screen)
 - Magenta : [Favorites Menu] (Editing screen)
- 8 Remaining Battery Power

(P32 [Power Status Display])

Memo : _____

- If the recommended battery (or equivalent battery sold separately) is not used, the battery mark which indicates the battery level may not appear.

- 9 Menu Title

Title of the currently displayed menu.

Changing Setting Values

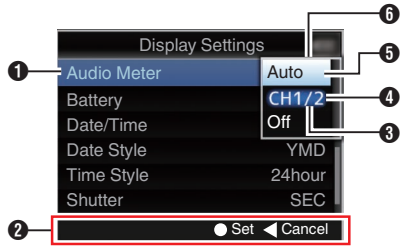

- 1 Menu Item to Change
Menu item to be changed.
A list of setting values 6 appears in a pop-up.
- 2 Operation Guide
Guide for the current operation buttons.
- 3 Setting Values Before Change
Setting values before changing. The background of the item is displayed in blue.
- 4 Scroll Bar
Indicates the scroll position.
- 5 Cursor
Indicates the selected item. Use the cross-shaped button (▲▼) to move the cursor
- 6 List of Setting Values
 - A pop-up displaying a list of setting values for selection.
 - The height of the pop-up depends on the number of settings available. Use the scroll bar 4 to confirm the current display status.

Text Input with Software Keyboard

For entering the subname for the setup file, entering the [Clip Name Prefix], and the settings under [Network] → [Settings].

Entering a subname

(☞ P157 [Configuring Setup Files])

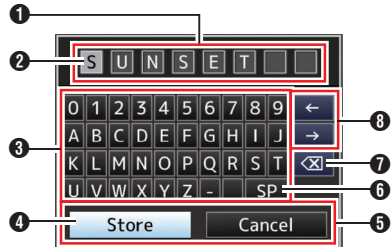

Entering the [Clip Name Prefix]

(☞ P137 [Clip Name Prefix])

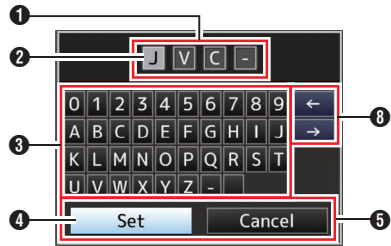

Settings under [Network] → [Settings]

The keyboard displayed varies according to the settings.

(☞ P137 [Network/Settings Item])

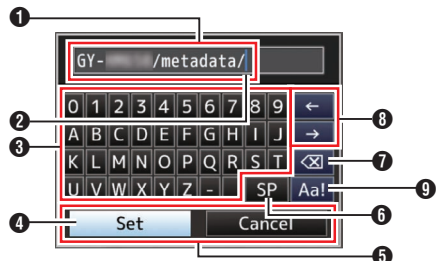

- 1 **Character Entry Field**
 - Field for entering the title.
 - You can enter up to 8 characters for the [Scene File]/[Picture File] subtitle or up to 4 characters for the [Clip Name Prefix].
- 2 **Character Cursor**
Select a character using the key cursor 4, and press the Set button (●) to input the selected character at the position of the character cursor. The character cursor moves to the next position on the right each time a character is input. The cursor can be moved using the arrow keys 8.
- 3 **Character Keys**
Use the cross-shaped button (▲▼◀▶) to move the key cursor 4 to the character you want to enter.
- 4 **Key Cursor**
Indicates the currently selected character or item. Use the cross-shaped button (▲▼◀▶) to move the cursor.
- 5 **Confirmation Buttons**
 - Select [Set]/[Store] and press the Set button (●) to confirm the title.
 - Select [Cancel] and press the Set button (●) on the side control panel of the camera recorder to abort character input and return to the previous screen.
- 6 **[SP] Space Key**
Select [SP] and press the Set button (●) on the side control panel of the camera recorder to enter a space at the current position of the character cursor 2.
- 7 **[<X>] Backspace Key**
Select [<X>] and press the Set button (●) on the side control panel of the camera recorder to delete the character on the left of the character cursor 2.
- 8 **Arrow Keys**
Moves the position of the character cursor 2.
- 9 **Character Switch Button**
Switches the character buttons 3 to the upper case, lower case, and symbols.

About the Menu Lock Feature

This is a feature for preventing the menu settings from being altered.

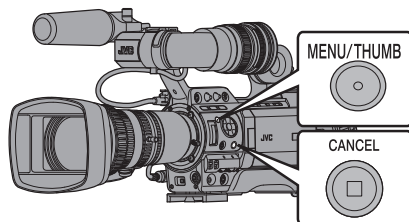

1 While in the Camera mode (when the display screen appears), press and hold the [CANCEL] and [MENU/THUMB] buttons at the same time for 5 seconds or longer.

All menu operations are disabled. Switching from the display screen to the menu screen is also disabled.

Memo : _____

- Powering off the camera recorder turns off the menu lock.

Menu Screen Hierarchical Chart

[Main Menu...]	(P 107)	[Color Gain]	(P 116)
└ [Camera Function...]	(P 108)	└ [Reverse Picture]	(P 116)
├ [Bars]	(P 108)	└ [Shooting Mode]	(P 117)
├ [OIS]	(P 108)	└ [Reset Process]	(P 117)
├ [Flicker Correction]	(P 108)	[TC/UB...]	(P 119)
├ [Flash Band Correction]	(P 108)	├ [TC Preset]	(P 119)
├ [Shutter]	(P 108)	├ [UB Mode]	(P 119)
├ [AE Level]	(P 109)	└ [Drop Frame]	(P 119)
├ [AE Speed]	(P 109)	[LCD/VF...]	(P 120)
├ [ALC Limit]	(P 109)	├ [Shooting Assist...]	(P 120)
├ [Auto Iris Limit (OPEN)]	(P 109)	├ [Marker Settings...]	(P 120)
├ [Auto Iris Limit (CLOSE)]	(P 109)	├ [Display Settings...]	(P 120)
├ [EEI Limit]	(P 109)	├ [LCD + VF]	(P 120)
├ [Smooth Trans]	(P 109)	├ [LCD/VF Display]	(P 120)
├ [FAW]	(P 109)	├ [VF Color]	(P 120)
├ [GAIN L]	(P 109)	├ [VF Contrast]	(P 120)
├ [GAIN M]	(P 109)	├ [LCD Contrast]	(P 120)
├ [GAIN H]	(P 109)	├ [LCD Backlight]	(P 120)
├ [AE LEVEL SW]	(P 109)	└ [LCD Mirror]	(P 120)
├ [Handle Zoom Speed]	(P 110)	[A/V Set...]	(P 125)
├ [AF Speed]	(P 110)	├ [Video Set...]	(P 125)
├ [AF Assist]	(P 110)	└ [Audio Set...]	(P 125)
├ [Remote Func. Change]	(P 110)	[System...]	(P 130)
├ [Lens REC] (*)	(P 110)	├ [Record Set...]	(P 130)
├ [User Switch Set...]	(P 110)	├ [Media]	(P 130)
└ [FULL AUTO...]	(P 110)	├ [Setup File]	(P 130)
[Camera Process...]	(P 114)	├ [Tally System]	(P 130)
├ [Detail]	(P 114)	├ [Front Tally]	(P 130)
├ └ [Adjust...]	(P 114)	├ [Back Tally]	(P 130)
├ [Master Black]	(P 114)	├ [GPS]	(P 130)
├ [Black Toe]	(P 114)	├ [Language]	(P 131)
├ [Knee]	(P 115)	├ [Network]	(P 131)
├ [White Clip]	(P 115)	├ └ [Settings]	(P 131)
├ [Gamma]	(P 115)	├ [System Frequency]	(P 131)
├ [WDR]	(P 116)	├ [Reset All]	(P 131)
├ [White Balance...]	(P 116)	├ [Date/Time]	(P 131)
├ [Color Matrix]	(P 116)	├ [Time Zone]	(P 131)
├ └ [Adjust]	(P 116)	└ [System Information]	(P 132)

* Displayed only when KA-F790G is connected

Memo :

- Some menus cannot be set depending on the operating mode or status of the camera recorder. These items are displayed in gray, and they cannot be selected.
- Setting value with the ● mark is the factory default.
- Remotely controlled items are displayed as  and cannot be selected.

Camera Function Menu

Menu screen for specifying operation settings during shooting.

This item can only be selected in the Camera mode.

Bars

For setting whether to output color bars.

[Setting Values: On, ●Off]

Memo : _____

- The audio test signals (1 kHz) can be output simultaneously with the color bar output. (P129 [Test Tone])
- This feature will be set to “Off” automatically if you switch the camera recorder from the Camera mode to other modes or set the [POWER ON/OFF] switch to “OFF”.

OIS LENS

For setting whether to enable image stabilizer.

When “On” is selected, set the Level.

[Setting Values: On, ●Off]

- * When the supplied lens is not attached, “---” is displayed and selection cannot be made.

↳ Level

For setting the level of the image stabilizer.

[Setting Values: High, ●Normal]

Memo : _____

- When “High” is selected, correcting severe camera shake may cause the area surrounding the image to darken.

Flicker Correction

For setting whether to adjust image flicker that occurs under a fluorescent light.

[Setting Values: On, ●Off]

Memo : _____

- In any of the following cases, “Off” is displayed and selection cannot be made.
 - During slow shutter
 - When [Rec Mode] is set to “Variable Frame”
 - When the number of frames of [A]Frame & Bit Rate/[B]Frame & Bit Rate] is “24p”

Flash Band Correction

For reducing the condition of the flash band phenomenon, which creates an unnatural image with a part of it brightly lit, such as by the camera flash of another still camera.

[Setting Values: On, ●Off]

Caution : _____

- Flash band correction function is not available in any of the following cases.
 - When [Rec Mode] is set to “Variable Frame”
 - When the frame rate of [A]Frame & Bit Rate/[B]Frame & Bit Rate] is “24p”
 - When the shutter speed is set to a value other than OFF
 - (P60 [Manual Shutter Mode (Manual Shutter Switching)])
 - When [Network] is set to “On(SDI Off)” or “On(HDMI Off)”
- [Flash Band Correction] operates when the luminance of the screen varies widely, with or without flash light. However, depending on the shooting condition, the flash band correction may not be fully effective even if there are flash lights.
- The following symptoms may occur under flash light, but these are not malfunctions due to flash band correction.
 - Moving object appears to be stationary momentarily.
 - A horizontal line appears on the image.
- The [Flash Band Correction] feature will be set to “Off” automatically if you switch the camera recorder from the Camera mode to other modes or set the [POWER ON/OFF] switch to “OFF”.

Shutter

For specifying shutter-related settings.

Use this item to set to “Step” (fixed value) or

“Variable” when operating with the cross-shaped button (▲▼) on the right side.

- EEI:
 - Select this to perform automatic control of the shutter.
- Variable:
 - Sets to variable scan. Use this setting such as when shooting a PC monitor.
- Step:
 - Sets to step shutter, which switches the shutter speed by a fixed value.

[Setting Values: EEI, Variable, ●Step]

AE Level

For setting the convergence level during AE (Auto Exposure).

This can also be adjusted using the cross-shaped button (◀▶) on the right side.

[Setting Values: -6 to +6 (●0)]

Memo : _____

- In all the following cases, “---” is displayed and selection cannot be made.
 - When gain is set to a value other than “ALC”
 - When [Shutter] is set to a value other than “EEI”
 - When the [IRIS A/M] selection switch is set to “M” (only when the supplied lens is used)

AE Speed

For setting the convergence speed during AE (Auto Exposure).

[Setting Values: ●Fast, Middle, Slow]

ALC Limit

For setting the maximum gain value of “ALC”, which electrically boosts the sensitivity level according to the brightness automatically.

[Setting Values: 24dB, ●18dB, 12dB, 6dB]

Auto Iris Limit (OPEN)

For setting the limit value of the OPEN end when auto iris is enabled.

[Setting Values: F5.6, F4, F2.8, F2, F1.6, ●F1.4]

Auto Iris Limit (CLOSE)

For setting the limit value of the CLOSE end when auto iris is enabled.

[Setting Values: ●F16, F11, F8, F5.6]

EEI Limit

For setting the shutter speed control range when the Automatic Shutter mode (EEI) is enabled.

[Setting Values: 4F-stop, ●3F-stop, 2F-stop]

Smooth Trans

For setting the shock reduction function, which slows down the sudden change when switching with the [GAIN L/M/H] selection switch or [WHT.BAL B/A/PRESET] switch.

[Setting Values: Fast, Middle, Slow, ●Off]

Memo : _____

- This feature does not function when the [FULL AUTO] switch is “ON”, while the [GAIN L/M/H] selection switch or [WHT.BAL B/A/PRESET] switch is disabled.

FAW

For setting where to assign the FAW (Full Auto White Balance) feature in the [WHT.BAL B/A/PRESET] switch.

[Setting Values: B, A, PRESET, ●None]

Memo : _____

- When the [FULL AUTO] switch on the camera recorder is set to “ON”, and [FULL AUTO] → [White Balance] is set to “FAW”, the setting is fixed at “FAW”.

GAIN L, GAIN M, GAIN H

For setting the gain value of each position on the [GAIN L/M/H] selection switch.

When “ALC” is selected, the camera recorder switches to the Auto Gain mode.

[Setting Values: ALC, 24dB, 21dB, 18dB, 15dB, 12dB, 9dB, 6dB, 3dB, 0dB, -3dB, -6dB]

(Default values GAIN L: 0dB, GAIN M: 6dB, GAIN H: 12dB)

Memo : _____

- When the [FULL AUTO] switch on the camera recorder is set to “ON”, and [FULL AUTO] → [Gain] is set to “ALC”, the setting is fixed at “ALC”.

AE LEVEL SW

For specifying the operation of the cross-shaped button (◀▶) on the right side.

- AE LEVEL/VFR:
 - Sets the number of frames during Variable Frame Rec, and operates as the AE level setting button in other cases.
 - (P93 [Variable Frame Rec])
- AE Level:
 - Operates as the AE level setting button at all times.
- Disable:
 - Disables the button.

[Setting Values: AE LEVEL/VFR, ●AE Level, Disable]

Handle Zoom Speed LENS

This function allows you to set the zoom speed of the zoom lever at the handle when the [ZOOM FIX/VAR/OFF] switch is set to "FIX".

[Setting Values: 1 to 8 (● 5)]

- * When the supplied lens is not attached, "---" is displayed and selection cannot be made.

AF Speed LENS

For setting the AF operation speed.

[Setting Values: Fast, ●Middle, Slow]

AF Assist LENS

For setting whether to shift the auto focus point when the focus ring is turned during Auto Focus (AF).

- * When the supplied lens is not attached, "---" is displayed and selection cannot be made.

- Area:
This option allows you to shift the auto focus point to the left, center, right, or near and far directions by turning the focus ring during AF. Selecting this option displays the  icon in the area.
- Far/Near:
This option allows you to shift the auto focus point to near and far directions by turning the focus ring during AF.

[Setting Values: Area, Far/Near, ●Off]

(☞ P54 [AF Assist Function LENS])

Memo : _____

- This setting is effective only when the [AUTO FOCUS/11] switch is set to "ON".
- The manual focus adjustment mode is temporarily activated by turning the focus ring in the AF mode. If the focus ring is not operated for a certain time, the camera recorder returns to the AF mode.

Remote Func. Change LENS

For setting whether to enable focus operation when performing zooming from a wired remote control. [Setting Values: Zoom → Focus, ●Off]

Memo : _____

- This function is effective only if a wired remote control is connected to the [REMOTE2] terminal.

Lens REC (Displayed only when KA-F790G is connected) 890 890CH

For setting the function of the [REC] button on the lens.

- Intercom:
Functions as an ON/OFF button for headset calls. Pressing the button each time toggles headset call between on/off. Press and hold down the button to turn on headset call. Release to turn off.
- Rec:
Functions as a recording button to start or stop recording.

[Setting Values: Intercom, ●Rec]

User Switch Set...

For specifying user button related settings.

(☞ P111 [User Switch Set Item])

FULL AUTO...

For setting which feature to set to auto when the [FULL AUTO] switch on the camera recorder is "ON".

(☞ P113 [FULL AUTO Item])

User Switch Set Item

USER1 to USER11, Lens RET

By assigning one of the menu functions below to the [OIS/1], [MARKER/2], [LOAD FILE/3], [F.ASSIST/4], [▲/5], [▼/6], [7/◀/ZEBRA], [8/▶/SPOT METER], [AWB/9], [REC/10], [AUTO FOCUS/11] buttons and the [RET] button on the lens, you can operate the preset function (on/off, startup, switching). Set according to the shooting conditions. Usable only in the Camera mode. The settable values for each item are as follows.

Setting Value \ Item	Lens RET	USER9, USER10	USER11
Live Streaming	✓	✓	—
Load Picture File	✓	✓	—
Return Video 890 890CH	✓	✓	—
Clip Review	✓	✓	—
OK Mark	✓	✓	—
Clip Cutter Trig	✓	✓	—
Backup Trig	✓	✓	—
Rec	—	✓	—
LCD Backlight	✓	✓	✓
Expanded Focus	✓	✓	—
Histogram	✓	✓	✓
Spot Meter	✓	✓	—
Focus Assist	✓	✓	✓
Marker	✓	✓	✓
Zebra	✓	✓	✓
AWB	✓	✓	—
White Balance	✓	✓	—
Preset Zoom1 to Preset Zoom3	✓	✓	—
Auto Focus LENS	✓	✓	✓
One Push Focus LENS	✓	✓	—
One Push Iris LENS	✓	✓	—
OIS LENS	✓	✓	✓
Face Detect LENS	✓	✓	—
AE Lock	✓	✓	—
Lolux	✓	✓	✓
Flash Band	✓	✓	✓
Bars	✓	✓	—
None	✓	✓	✓

✓ : Settable — : Not settable

Lolux

To increase the sensitivity when in dim surroundings, set a value in the Lolux mode. [Setting Values: 36dB, ●30dB]

Clip Review

For setting the operation of clip review.

* Clip review functions by operating the user button assigned with the “Clip Review” function.

- Last 5sec:
Views about 5 seconds of the clip from the ending.
- Top 5sec:
Views about 5 seconds of the clip from the beginning.
- Clip:
Views the entire clip.

[Setting Values: ●Last 5sec, Top 5sec, Clip]

Spot Meter

For setting the operation of the spot meter.

* Spot meter functions by operating the user button assigned with the “Spot Meter” function.

( P80 [Setting Spot Meter])

- Max & Min:
Displays the brightest and darkest areas of the image.
- Max:
Displays the brightest area of the image.
- Min:
Displays the darkest area of the image.
- Manual:
Displays the image brightness at a specified position.

[Setting Values: ●Max & Min, Max, Min, Manual]

Face Detect LENS

Select the control to track results of face detection.

- * Face Detect functions by operating the user button assigned with the “Face Detect” function.
- * When the supplied lens is not attached, “---” is displayed and selection cannot be made.

- **AF&AE:**

Sets auto focus and exposure control for the face that is being tracked.

- **AF:**

Sets auto focus for the face that is being tracked.

[Setting Values: ●AF&AE, AF]

 P56 [Adjusting the Focus by Face Detection LENS]

Memo : _____

- When “AF” is selected, face detection operates only in the Autofocus mode. When “AF&AE” is specified, this function will be activated only when [AUTO FOCUS/11] is set to “ON”, or when one or more of the items (Gain, Iris and Shutter) is set to Auto mode.

↳ Sensitivity

For setting the level of ease of face detection.

[Setting Values: ●High, Middle, Low]

↳ Hysteresis

For setting the margin to maintain status when the face that is being tracked is lost.

Set to “Fast” to select another object immediately if the face on the screen is lost.

Set to “Slow” to operate at the same position for some time even if the face on the screen is lost.

[Setting Values: Fast, ●Middle, Slow]

AE Lock

For setting the operation of the AE lock.

- * AE lock functions by operating the user button assigned with the “AE Lock” function.
- **AE:**
Use this feature to fix a value to the Auto function of Gain, Iris, or Shutter when the user button that is assigned “AE Lock” is pressed.

- **AE/WB:**

Use this feature to fix a value to White Balance and the Auto function of Gain, Iris, or Shutter when the user button that is assigned “AE Lock” is pressed.

[Setting Values: ●AE, AE/WB]

Memo : _____

- This feature only works when Iris, Shutter or Gain is set to the Auto mode. However AE lock functions during FAW when “AE/WB” is selected.
- “AE Lock” is canceled when the button assigned with “AE Lock” is pressed, or when any of the functions that can be locked is operated regardless of the mode (Manual or Auto).

Preset Zoom Speed LENS

For setting the speed to shift to the preset zoom position that is assigned to a user button.

[Setting Values: 1 to 127 (● 64)]

Expanded Focus

For setting the operation of the expanded focus.

- * Expanded focus functions by operating the user button assigned with the “Expanded Focus” function.
 - **Toggle:**
Pressing the button assigned with “Expanded Focus” each time switches the “Expanded Focus” function to on or off.
 - **Momentary:**
The “Expanded Focus” function is enabled during the interval while the button assigned with “Expanded Focus” is pressed.
 - **Limited Time:**
Activates the timer. During autofocus, the [Expanded Focus] feature turns off about 3 seconds after it is turned on. During manual focus, the [Expanded Focus] feature turns off about 3 seconds after you stop operating the focus ring.
- [Setting Values: ●Toggle, Momentary, Limited Time]

Return Video

For setting method of displaying return videos and the switching operation.

- * Switching of the return video display functions by operating the user button assigned with the “Return Video” function.
- Camera ⇄ PiP:
Pressing the user button assigned with the “Return Video” function each time toggles between the captured video and picture-in-picture return video.
- Camera ⇄ PiP:
The picture-in-picture return video is displayed when the user button assigned with the “Return Video” function is pressed and held down, and the captured video is displayed when the button is released.
- PiP ⇄ Camera:
The captured video is displayed when the user button assigned with the “Return Video” function is pressed and held down, and the picture-in-picture return video is displayed when the button is released.
- PiP ⇄ Return:
The return video is displayed when the user button assigned with the “Return Video” function is pressed and held down, and the picture-in-picture return video is displayed when the button is released.
- Camera ⇄ Return:
The return video is displayed when the user button assigned with the “Return Video” function is pressed and held down, and the captured video is displayed when the button is released.

[Setting Values: Camera ⇄ PiP, Camera ⇄ PiP, PiP ⇄ Camera, PiP ⇄ Return, ●Camera ⇄ Return]

Memo : _____

- When [A/V Set] → [Video Set] → [Return Input] is set to “SDI”, this item is fixed at “Camera ⇄ Return”.

FULL AUTO Item

Gain

- SW Set:
In the Full Auto mode, the gain operation follows the setting of the [GAIN L/M/H] selection switch.
- ALC:
In the Full Auto mode, gain is set forcibly to “ALC” (forced auto).

[Setting Values: SW Set, ●ALC]

Memo : _____

- If the remote control unit comes with an FAS feature, the setting is fixed at “ALC” and selection is disabled.
(☞ P166 [Functions Operable from the Remote Control Unit])

Iris Control

When “Off” is selected, iris control cannot be performed in the Full Auto mode.

[Setting Values: Off, ●Auto]

Memo : _____

- If the remote control unit comes with an FAS feature, the setting is fixed at “Auto” and selection is disabled.
(☞ P166 [Functions Operable from the Remote Control Unit])
- When the [IRIS A/M] mode switch on the lens is set to “A” (Auto), the iris setting is fixed at the point this item is changed from “Auto” to “Off”.

Shutter

- SW Set:
In the Full Auto mode, the shutter operation follows the setting of the switch.
- EEI:
In the Full Auto mode, shutter is set to forced auto.

[Setting Values: SW Set, ●EEI]

Memo : _____

- If the remote control unit comes with an FAS feature, the setting is fixed at “EEI” and selection is disabled.
(☞ P166 [Functions Operable from the Remote Control Unit])

White Balance

- **SW Set:**
In the Full Auto mode, the white balance operation follows the setting of the [WHT.BAL B/A/PRESET] switch.
- **FAW:**
In the Full Auto mode, white balance is set to forced auto.

[Setting Values: SW Set, ●FAW]

Memo : _____

- If the remote control unit comes with an FAS feature, the setting is fixed at “FAW” and selection is disabled.
(☞ P166 [Functions Operable from the Remote Control Unit])

Bars

- **Menu Set:**
In the Full Auto mode, color bar output follows the menu setting by switch operation.
- **Off:**
In the Full Auto mode, color bar output is set forcibly to Off.

[Setting Values: Menu Set, ●Off]

Memo : _____

- If the remote control unit comes with an FAS feature, the setting is fixed at “Off” and selection is disabled.
(☞ P166 [Functions Operable from the Remote Control Unit])

Audio

- **SW Set:**
In the Full Auto mode, the audio recording level follows the settings of the [AUDIO SELECT] switch and [AUDIO LEVEL] adjustment knob.
- **Auto:**
In the Full Auto mode, audio recording level is set to forced auto.

[Setting Values: SW Set, ●Auto]

Camera Process Menu

Menu screen for adjusting the quality of camera images.

This item cannot be selected in the Media mode.

Detail

For adjusting the contour (detail) enhancement level.

Increasing the value increases the sharpness of the contour.

[Setting Values: -10 to +10, Off (●0)]

↳ Adjust...

For specifying the detailed settings of the contour (detail).

(☞ P117 [Detail/Adjust Item])

Memo : _____

- This item cannot be selected when [Detail] is set to “Off”.

Master Black

For adjusting the pedestal level (master black) that serves as the reference black.

Increasing the value increases the pedestal.

[Setting Values: -50 to +50 (●-3)]

Black Toe

Process the dark areas according to the balance of bright and dark areas in the image to adjust the overall balance of contrast.

For altering the gain of dark areas. Adjust this item according to the condition of the captured video signals.

- **Stretch:**
Increases the gain of dark areas in an image to stretch the signals of these areas only, thereby showing the contrast between bright and dark areas more clearly.
Specify the amount of stretch with [Stretch Level].
- **Normal:**
Normal condition.
- **Compress:**
Compresses the gain of dark areas to increase the contrast when the entire image appears bright and contrast is weak. Specify the compression amount with [Compress Level].

[Setting Values: Stretch, ●Normal, Compress]

Memo : _____

- When [WDR] is set to other than “Off”, this item appears as “---” and cannot be selected.

↳ Stretch Level

Stretch amount increases when a larger value is specified.

[Setting Values: 1 to 5 (● 3)]

Memo : _____

- This item is displayed only when [Black Toe] is set to "Stretch". Otherwise, this item appears as "---" and cannot be selected.

↳ Compress Level

Compression amount increases when a larger value is specified.

[Setting Values: 1 to 5 (● 3)]

Memo : _____

- This item is displayed only when [Black Toe] is set to "Compress". Otherwise, this item appears as "---" and cannot be selected.

Knee

For specifying the "Knee" operation, which compresses video signals beyond a certain level to show the gradation of the highlighted portion. To check the gradation of a bright area, set to "Manual" and adjust the knee point (starting point of knee operation) manually.

- Manual:
Enables manual adjustment of knee point using [Level].
- Auto:
Adjusts the knee point automatically according to the luminance level.

[Setting Values: Manual, ●Auto]

Memo : _____

- When [WDR] is set to other than "Off", this item appears as "---" and cannot be selected.

↳ Level

For setting the starting point (knee point) of knee compression when [Knee] is set to "Manual".

[Setting Values: ●100.0%, 97.5%, 95.0%, 92.5%, 90.0%, 87.5%, 85.0%]

Memo : _____

- When [Knee] is set to other than "Auto", or [WDR] is set to other than "Off", this item appears as "---" and cannot be selected.

↳ Sensitivity

For setting the response speed of the "Knee" operation when [Knee] is set to "Auto".

Set to "Slow" when shooting an object under a condition where there is drastic change in the light intensity.

[Setting Values: ●Fast, Middle, Slow]

Memo : _____

- When [Knee] is set to "Manual", or [WDR] is set to other than "Off", this item appears as "---" and cannot be selected.

White Clip

For setting the point to apply white clip for input video signals with a high luminance level.

- 108%:
Applies white clip at the point where the luminance level is 108 %.
- 103%:
Applies white clip at the point where the luminance level is 103 %.
- 100%:
Applies white clip at the point where the luminance level is 100 %. Set to this value when the system in use limits Y output signals within 100 %.

[Setting Values: ●108%, 103%, 100%]

Memo : _____

- When [WDR] is set to other than "Off", this item appears as "108%" and cannot be selected.

Gamma

For adjusting the gamma curve that determines the gradation expression.

- Cinema:
Sets to a gamma curve with similar gradation to the screen characteristics of movies.
- Standard:
Sets to a standard gamma curve.

[Setting Values: Cinema, ●Standard]

Memo : _____

- When [WDR] is set to other than "Off", this item appears as "---" and cannot be selected.

↳ Level

This item can be specified separately when [Gamma] is set to “Standard” or “Cinema”.

- Increase the number:
Enhances the gradation of black. However, the gradation of bright areas deteriorates.
- Decrease the number:
Enhances the gradation of bright areas.
However, the gradation of black deteriorates.

[Setting Values: -5 to +5 (● 0)]

WDR

For setting the WDR (Wide Dynamic Range) function.

When shooting object with wide dynamic range due to backlight conditions, this function compresses the dynamic range while maintaining image contrast through providing gradation compensation to the input video signals.

- Strong:
Enhances the effect of gradation compensation for object with wide dynamic range due to outdoor or strong backlight conditions.
- Natural:
Normal setting for wide dynamic range.
- Weak:
Reduces the effect of gradation compensation compared to the normal setting.
- Off:
Sets the wide dynamic range function to “Off”.

[Setting Values: Strong, Natural, Weak, ●Off]

Memo : _____

- When [WDR] is set to other than “Off”, [Black Toe], [Knee], [Gamma] and [White Clip] cannot be selected.

White Balance...

Menu for adjusting white balance.

(☞ P118 [White Balance Item])

- * For details, refer to “[Adjusting the White Balance] (☞ P 63)”.

Color Matrix

For setting the color matrix.

- Cinema Subdued:
Sets to a subdued color matrix that is similar to the screen characteristics of movies.
- Cinema Vivid:
Sets to a vivid color matrix that is similar to the screen characteristics of movies.
- Standard:
Sets to a standard color matrix.
- Off:
Sets the color matrix function to Off.

[Setting Values: Cinema Subdued, Cinema Vivid, ●Standard, Off]

↳ Adjust

This item is used to adjust [Color Matrix] to a color according to the user’s preference.

- This item is used to adjust [Color Matrix] to a color according to the user’s preference.
- The saturation, hue and brightness of the primary and complementary colors (6 colors in total) can be set individually.
- The adjusted values of “Standard”, “Cinema Vivid”, and “Cinema Subdued” in [Color Matrix] can be stored individually.

(☞ P156 [Adjusting Color Matrix])

[Setting range for Lightness/Saturation: -10 to +10] (roughly ± 10 %)

[Setting range for Hue: -5 to +5] (roughly ± 5°)

Memo : _____

- This item cannot be selected when [Color Matrix] is set to “Off”.

Color Gain

For adjusting the video signal color level. Increasing the value deepens the color.

[Setting Values: -50 to +15, Off (●0)]

Memo : _____

- Images are displayed in black-and-white when this is set to “Off”.

Reverse Picture

For recording images correctly by setting this item to “Rotate” when the lens image appears upside down or laterally inverted.

- Rotate:
Enables horizontal/vertical inversion of the image.
- Off:
Disables horizontal/vertical inversion of the image.

[Setting Values: Rotate, ●Off]

Shooting Mode

For switching the settings for image recording on the camera.

- **Standard:**
Normal shooting mode.
This setting is suitable for shooting low-noise image quality.
Use this mode in well lit places.
- **Extended:**
High sensitivity shooting mode.
This setting enables recording in various brightness conditions.
Use this mode in places where the lighting is difficult to control and the brightness is insufficient.

[Setting Values: ●Standard, Extended]

Reset Process

Restores all items in the [Camera Process] menu to their default settings.

Detail/Adjust Item

V/H Balance

For setting the H/V balance to enhance contour (detail) in the horizontal (H) or vertical (V) direction.

- **H+1 to H+4:**
Increasing the value enhances contour in the horizontal direction.
- **V+1 to V+4:**
Increasing the value enhances contour in the vertical direction.

[Setting Values: H+1 to H+4, ●Normal, V+1 to V+4]

Memo : _____

- When [System] under [Record Format] is set to “SD”, this item is fixed at “Normal”.
- When [System] under [Record Format] is set to “HD+SD”, this item can be set during HD recording, but will be fixed at “Normal” during SD recording.

H Frequency

For specifying the correction frequency of the horizontal contour. Set this according to the object.

- **High:**
Emphasizes the high frequency range. Use this when shooting objects with fine patterns.
- **Middle:**
Emphasizes the intermediate frequency range.
- **Low:**
Emphasizes the low frequency range. Use this when shooting objects with large patterns.

[Setting Values: High, ●Middle, Low]

Memo : _____

- When [System] under [Record Format] is set to “SD”, this item is fixed at “Low”.
- When [System] under [Record Format] is set to “HD+SD”, this item can be set during HD recording, but will be fixed at “Low” during SD recording.

Skin Detail

For turning On/Off the Skin Detail function, which is used to adjust the contour correction effect of the colors captured.

Select “On” to soften the detail at areas where skin tone is detected.

[Setting Values: On, ●Off]

↳ Level

For setting the level of contour correction (degree of softening) using the Skin Detail function. Decreasing the value increases the level of contour correction (degree of softening).

[Setting Values: -1, ● -2, -3]

↳ Range

For adjusting the range of skin tone to trigger the Skin Detail function.

Increasing the value increases the range.

[Setting Values: -5 to +5 (●0)]

White Balance Item

Preset Temp.

For setting the color temperature when the [WHT.BAL B/A/PRESET] switch is set to "PRESET".

For details, refer to "[Adjusting the White Balance] (P 63)".

Alternative Temp.

For setting the alternative color temperature in the Preset mode.

When the [WHT.BAL B/A/PRESET] switch is set to "PRESET", pressing the user button assigned with the "AWB" function each time switches the color temperature setting in the Preset mode. ([Preset Temp.] ↔ [Alternative Temp.])

For details, refer to "[Adjusting the White Balance] (P 63)".

AWB Paint

For adjusting the R (red)/B (blue) component in the AWB (Auto White Balance) mode.

For details, refer to "[Adjusting the White Balance] (P 63)".

- Increase the number:
Strengthens the red/blue.
- Decrease the number:
Weakens the red/blue.

[Setting Values: -32 to +32 (● 0)]

Memo : _____

- This item is selectable when the [WHT.BAL B/A/PRESET] switch on the right of the camera recorder is set to "A" or "B". When "PRESET" is set, this item appears as "--" and cannot be selected.
- Different values can be specified for "A" and "B".
- After executing AWB, the adjustment value becomes 0.
To maintain the adjustment value, set [Clear Paint After AWB] to "Off".

Clear Paint After AWB

For specifying whether to clear the [AWB Paint] (R value and B value) settings after executing AWB (Auto White Balance).

- On:
Sets the [AWB Paint] (R value and B value) settings to "0" after executing AWB (Auto White Balance).
- Off:
Does not change the [AWB Paint] (R value and B value) settings after executing AWB (Auto White Balance).

[Setting Values: ●On, Off]

FAW Paint

For adjusting the R (red)/B (blue) component during FAW (Full Auto White Balance) mode.

- Increase the number:
Strengthens the red/blue.
- Decrease the number:
Weakens the red/blue.

[Setting Values: -32 to +32 (● 0)]

Shading

For adjusting white shading.

- On:
Adjust white shading.
- Off:
Fixes white shading adjustment. Manual adjustment is not allowed.

[Setting Values: On, ●Off]

↳ Adjust...

Performs white shading adjustment when [Shading] is set to "On".

[Setting Values: -128 to +127 (● 0)]

(P66 [White Shading Adjustment])

TC/UB Menu

Menu screen for setting time code and user's bit. This item cannot be selected in the Media mode, or during recording.

TC Preset

For setting the time code (hour, minute, second, frame).

Display : Drop setting 02:02:25.20
: Non Drop setting 02:02:25:20

Memo : _____

- When the [TC GENE.] switch is set to "REGEN", "REGEN" is displayed and preset is disabled. (P73 [Setting Time Code Generator])

UB Mode

For setting the recording mode of the user's bit.

- Date:
Records the date.
- Time:
Records the time.
- SW Set:
Operates in the mode selected using the [TC GENE.] switch. (P76 [Setting the User's Bit])

[Setting Values: Date, Time, ●SW Set]

Memo : _____

- If UB Mode is set to "Time", the user's bit operates in the 24-hour format even if the LCD display is in the 12-hour format.

↳ Preset

For setting the user's bit. (Digit by digit)

Display : AB CD EF 01
(P76 [Presetting the User's Bit])

Memo : _____

- When [UB Mode] is set to "Date" or "Time", this item appears as "---" and preset is disabled.
- When the [TC GENE.] switch is set to "REGEN", "REGEN" is displayed and preset is disabled.

Drop Frame

For setting the framing mode of the time code generator.

- Non Drop:
Internal time code generator works in the non-drop-frame mode. Use this setting when placing emphasis on the number of frames.
- Drop:
Internal time code generator works in the drop-frame mode. Use this setting when placing emphasis on the recording time.

[Setting Values: Non Drop, ●Drop]

Memo : _____

- Settable only when [Main Menu] → [System] → [System Frequency] is set to "60/30/24", and [Main Menu] → [System] → [Record Set] → [Record Format] → [A]Frame & Bit Rate is set to "60p", "30p", or "60". When the frame rate is "24p", "Non Drop" becomes fixed and cannot be selected.
- When [Main Menu] → [System] → [System Frequency] is set to "50/25", "---" is displayed and selection is disabled. (P133 [A]Frame & Bit Rate)

LCD/VF Menu

Item for specifying settings related to the LCD monitor or viewfinder screen.

This menu screen can be used to specify settings related to the Focus Assist mode, zebra pattern display, screen size, marker, and safety zone. In addition, it is also used for selecting whether to display characters on the LCD monitor or viewfinder screen, as well as for adjusting the picture quality of the LCD monitor.

Shooting Assist...

Menu for setting the Shooting Assist function.

(P121 [Shooting Assist Item])

Marker Settings...

For setting items such as the safety zone and center mark.

(P121 [Marker Settings Item])

Display Settings...

For specifying display-related settings.

(P122 [Display Settings Item])

LCD + VF

For selecting a method to switch between the LCD monitor and viewfinder screen displays.

(P38 [Adjusting the LCD Monitor and Viewfinder])

- On:
Displays images on the viewfinder at all times.
- Off:
Turns off the viewfinder screen display when the LCD monitor is turned on.

[Setting Values: On, ●Off]

Memo : _____

- When [Network] is set to “On”, this item is fixed at “Off” and cannot be selected.

LCD/VF Display

For selecting the angle of view for displaying the image in the LCD monitor and viewfinder.

- Wide: Displays images in the full angle of view of the 16:9 recording format on both the LCD monitor and viewfinder.

The entire angle of view is displayed, so the image appears slightly vertically-long.

- Normal: Displays images in an angle of view equivalent to the 15:9 format on the LCD monitor, and an angle of view equivalent to the 16:9 format on the viewfinder.

(The image displayed on the LCD monitor appears slightly cropped at the left and right sides compared to the actual recorded image.)

[Setting Values: Wide, ●Normal]

VF Color

For selecting whether to display the image on the viewfinder screen in color or black-and-white. Select “On” to display in color, and “Off” to display in black-and-white.

[Setting Values: ●On, Off]

Memo : _____

- The setting of this item is valid only in Camera mode.
- When this item is set to “Off”, only the captured images are displayed in black-and-white. The display and menu screens are displayed in color.

VF Contrast

For setting the difference in luminance between the darkest and brightness areas in the viewfinder screen.

Increasing the value increases the contrast.

[Setting Values: -10 to +10 (● 0)]

LCD Contrast

For setting the difference in luminance between the darkest and brightness areas in the LCD monitor.

Increasing the value increases the contrast.

[Setting Values: -10 to +10 (● 0)]

LCD Backlight

For setting the brightness of the LCD monitor backlight.

[Setting Values: Bright, ●Normal]

LCD Mirror

For specifying the image display method when facing the LCD monitor.

Select “Mirror” to display the image after laterally inverting it. (Mirror display)

(P38 [Adjusting the LCD Monitor and Viewfinder])

[Setting Values: Mirror, ●Normal]

Memo : _____

- The setting of this item is valid only in Camera mode.
- During display of the color bar, the “Mirror” setting is disabled.
(P155 [Color Bar Output])
- During display of the return video, the “Mirror” setting is disabled.
(P172 [Displaying Return Videos from an External Device **890** **890CH**])

Shooting Assist Item

Focus Assist

For setting whether to add color to the contour of the focused image upon switching the image to black-and-white.

[Setting Values: On, ●Off]

↳ Type

For specifying the operation when the [F.ASSIST/4] button is pressed.

( P55 [Focus Assist Function])

- **ACCU-Focus:**
Enables the Focus Assist and ACCU-Focus (forced focus) functions. The depth of field of the object becomes shallower to enable easier focusing. The ACCU-Focus function switches automatically to “Off” after about 10 seconds.
- **Normal:**
Enables only the Focus Assist function. The focused area is displayed in color to enable easier focusing. Display color can be specified with [Color].

[Setting Values: ACCU-Focus, ●Normal]

↳ Color

For setting the display color of the focused area when Focus Assist is activated.

[Setting Values: ●Blue, Green, Red]

Zebra

For selecting whether the number of zebra patterns to display at the bright areas of the subject.

- **2Patterns:**
Displays two types of zebra patterns (Zebra1 and Zebra2).
- **1Pattern:**
Displays one type of zebra pattern (Zebra1).

[Setting Values: 2Patterns, ●1Pattern]

↳ Top 1

For setting the maximum brightness level for displaying the Zebra 1 pattern.

[Setting Values: Over, 100% to 5% (in 5% increments)] (●80%)

↳ Bottom 1

For setting the minimum brightness level for displaying the Zebra1 pattern.

[Setting Values: 100% to 0% (in 5% increments)] (●70%)

↳ Top 2

For setting the maximum brightness level for displaying the Zebra 2 pattern.

[Setting Values: Over, 100% to 5% (in 5% increments)] (●Over)

Memo : _____

- This item cannot be selected when [Zebra] is set to “1Pattern”.

↳ Bottom 2

For setting the minimum brightness level for displaying the Zebra 2 pattern.

[Setting Values: 100% to 0% (in 5% increments)] (●80%)

Memo : _____

- This item cannot be selected when [Zebra] is set to “1Pattern”.

Peaking Frequency

For setting the frequency bandwidth for emphasizing the outline using the [VF PEAKING] adjustment knob or [LCD PEAKING +/-] button.

[Setting Values: ●High, Middle, Low]

Marker Settings Item

For setting the marker and safety zone, which are useful in helping you determine the angle of view for the image according to the shooting purpose.

( P154 [Marker and Safety Zone Displays])

Memo : _____

- During Clip Review or when in the Media mode, the markers do not appear regardless of the setting.

Marker Settings

For setting whether to display the marker, safety zone, and center marks on the screen.

[Setting Values: On, ●Off]

↳ Grid Marker

For setting whether to display a 3x3 grid on the screen.

[Setting Values: On, ●Off]

Memo : _____

- When [Grid Marker] is set to “On”, [Aspect Ratio], [Aspect Marker], and [Safety Zone] do not function.

↳ Aspect Ratio

For selecting the final image aspect ratio to be used from the overall angle of view.

[Setting Values: 16:9(+4:3), 2.35:1, ●16:9, 1.75:1, 1.66:1, 14:9, 13:9, 4:3, 2.35:1 Center, 2.35:1 Top, 1.85:1 Center, 1.85:1 Top]

Memo : _____

- When [Grid Marker] is set to “On”, this item appears as “---” and cannot be selected.
- When [System] → [Record Set] → [Record Format] → [SD Aspect] is set to “4:3”, this item is fixed at “4:3” and cannot be selected.
(P135 [SD Aspect])

↳ Aspect Marker

For specifying how boundary markers are to be used to indicate the parts of an image that are beyond the range of the aspect ratio selected in [Aspect Ratio].

- Line+Halftone:
Displays the boundary using lines, and areas outside the boundary in halftone.
- Halftone:
Displays areas outside the boundary in halftone.
- Line:
Displays the boundary using lines.
- Off:
Hides the boundary markers.

[Setting Values: Line+Halftone, Halftone, Line, ●Off]

Memo : _____

- When [Grid Marker] is set to “On”, this item appears as “---” and cannot be selected.
- When [Aspect Ratio] is set to “16:9” or “16:9(+4:3)”, this item is fixed at “Off” and cannot be selected.

↳ Safety Zone

For setting the percentage of area that is to be deemed as valid area (Safety Zone) within the boundary of the aspect ratio selected in [Aspect Ratio].

[Setting Values: 95%, 93%, 90%, 88%, 80%, ●Off]

Memo : _____

- When [Grid Marker] is set to “On”, this item appears as “---” and cannot be selected.

↳ Center Mark

For specifying whether to display a mark to indicate the screen center within the aspect ratio selected in [Aspect Ratio].

[Setting Values: ●On, Off]

| Display Settings Item

This menu is used to set the displays on the LCD monitor and viewfinder screen.

Zoom LENS

For setting the display method of the zoom position.

- Number:
Displays the zoom position in numbers (0-99).
- Bar:
Displays the zoom position in a bar.
- Off:
Does not display the zoom position.

[Setting Values: Number, ●Bar, Off]

* If the lens attached does not support zoom position information, “Off” is displayed and selection is disabled.

Focus LENS

For setting the display method of the approximate distance to the subject in focus during manual focus.

- Feet:
Displays the focus in feet.
- Meter:
Displays the focus in meters.
- Off:
Does not display the focal length during focus.

[Setting Values: Feet, ●Meter, Off]

* If the lens attached does not support focus position information, “Off” is displayed and selection is disabled.

ND Filter

For setting whether to display the filter position.

- On+Assist:
Displays the current filter position.
If the ND filter setting is inappropriate, the appropriate ND filter to select will appear blinking.
- On:
Displays the current filter position.
- Off:
Hides the filter position.

[Setting Values: On+Assist, ●On, Off]

Record Format

For setting whether to display the video format during recording or playback.

[Setting Values: ●On, Off]

Media Remain

For setting whether to display the remaining space of the recording SD card.

[Setting Values: ●On, Off]

Memo : _____

- When the remaining space warning is displayed, the information appears even when "Off" is selected.
- The displayed time is an estimate.

TC/UB

For specifying whether to display the time code or and user's bit on the LCD monitor or viewfinder screen.

Whether time code or user's bit is displayed is dependent on the setting of the [TC DISPLAY] switch inside the LCD monitor of the camera recorder.

[Setting Values: ●On, Off]

Histogram

For setting whether to display the histogram, which shows the distribution of different points with different levels of brightness in an image.

[Setting Values: On, ●Off]

Memo : _____

- When the histogram is displayed, the audio level meter display is turned off temporarily.

↳ Top

For selecting the maximum brightness limit for changing the histogram display color.

[Setting Values: 5% to 110% (in 5% increments)]
(● 80%)

↳ Bottom

For selecting the minimum brightness limit for changing the histogram display color.

[Setting Values: 0% to 105% (in 5% increments)]
(● 20%)

Audio Meter

For setting how the audio level meter is displayed on the LCD monitor or viewfinder screen.

- Auto:
4ch display when [System] → [Record Set] → [Record Format] → [Audio] is set to "4ch", and 2ch display ([CH-1]/[CH-2]) in all other cases. During playback, whether 4ch display or 2ch display ([CH-1]/[CH-2]) is used varies with the recorded clip.
- CH1/2:
Displays the audio level meter for [CH-1] and [CH-2].
- Off:
Audio level meter is not displayed.

[Setting Values: ●Auto, CH1/2, Off]

Memo : _____

- When [Histogram] is set to "On", this item is fixed at "Off" and selection is disabled.

Battery

For setting the display of the remaining battery power in the display on the LCD monitor and viewfinder screen.







The battery information appears only on the Display 2 screen in Camera mode.

(P145 [Display 2 screen])

- Time:
Displays the remaining battery power in minutes. (min)
- Capacity%:
Displays the remaining battery power in percentage. (%)
- Voltage:
Displays the current battery voltage in units of 0.1 V. (V)
- Off:
The remaining battery power is not displayed.

[Setting Values: ●Time, Capacity%, Voltage, Off]

Memo : _____

- The battery mark that appears before the “Time”, “Capacity%” or “Voltage” value changes according to the remaining battery power.
 -  : Battery which the capacity could not be acquired
 -  : Below 13%
 -  : 13% or higher
 -  : 30% or higher
 -  : 60% or higher
 -  : Battery communication error
 -  : Calibration required
- When the remaining battery power is low, “RES” instead of the value is displayed.
Replace the battery as soon as possible.
- The remaining battery power and remaining time are intended as reference values for the shooting duration.
- The remaining battery level may not be displayed depending on the type of battery connected.

Date/Time

For specifying whether to display the date and time in the display on the LCD monitor and viewfinder screen.

[Setting Values: ●On, Off]

Date Style

For setting the date display sequence for display on the LCD monitor and viewfinder screen as well as for time stamp recording.

Display examples of the setting values are as follows.

- DMY2: 30 Jun 2017
- DMY1: 30-06-2017
- MDY2: Jun 30, 2017
- MDY1: 06-30-2017
- YMD: 2017-06-30

[Setting Values: DMY2, DMY1, MDY1, MDY2, YMD]

(Default values: MDY2 (U model), DMY1 (E model))

Time Style

For setting the time display for display on the LCD monitor and viewfinder screen as well as for time stamp recording.

[Setting Values: 24hour, 12hour]

(Default values: 12hour (U model), 24hour (E model))

Shutter

For setting the shutter display to be displayed on the LCD monitor and viewfinder screen.

- DEG:
Displays the shutter speed in degrees in the same way as film cameras.
- SEC:
Displays the shutter speed in seconds.

[Setting Values: DEG, ●SEC]

Memo : _____

- “DEG” display is enabled only when the frame rate of [A]Frame & Bit Rate] is set to “25p” or “24p”.
When [A]Frame & Bit Rate] is set to other values, the shutter display setting is fixed at “SEC” and cannot be selected.
(P133 [A] Frame & Bit Rate])
- When a remote control unit is connected to the [REMOTE1] terminal, or when KA-M790G is connected to the camera and RM-HP790 to KA-M790G, “SEC” is displayed and selection is disabled.

A/V Set Menu

Menu screen for video output and audio.

Video Set...

For specifying video output-related settings.
(P125 [Video Set Item])

Audio Set...

For specifying audio-related settings.
(P127 [Audio Set Item])

Video Set Item

HDMI/SDI Out

For setting the terminal to output the video.
[Setting Values: HDMI+SDI, SDI, HDMI, ●Off]

Memo : _____

- When the [Network] setting is set to “On(SDI Off)”, “HDMI+SDI” and “SDI” are not selectable. And when “On(HDMI Off)” is set, “HDMI+SDI” and “HDMI” are not selectable.
- When KA-M790G (Multicore Remote Adapter: optional) is connected to the rear of the camera recorder and power is supplied from the 26-pin camera cable, “HDMI+SDI” is not selectable.

890 890CH

Resolution

For selecting the resolution of video output from the [HDMI]/[SDI] terminal according to the monitor to be connected.

[Setting Values: 576i, 576p, 480i, 480p, 720p, ●1080i, 1080p]

Memo : _____

- The selectable options vary according to the setting in [System]/[A]Resolution/[A]Frame & Bit Rate] of [System] → [Record Set] → [Record Format].
- Cross conversion output is not possible.
- When [GPS] is set to “On”, and [HDMI/SDI Out] is set to “HDMI+SDI” or “SDI”, “1080p” is not selectable. GPS

HDMI Color

- For setting the color format of HDMI signals.
- This item is selectable only when [HDMI/SDI Out] is set to “HDMI” or “HDMI+SDI”.

[Setting Values: RGB, ●Auto]

HDMI Enhance

- For setting the color range of HDMI signals. When connecting to a PC monitor, set this to “On”.
- This item is selectable only when [HDMI/SDI Out] is set to “HDMI” or “HDMI+SDI”.

[Setting Values: On, ●Off]

SDI Rec Trigger

For setting whether to superimpose trigger signals in tandem with the [HD/SD SDI OUT] terminal as well as the [REC] button on the camera body.

When a compatible device is connected, recording/stop control signals are output in tandem with the operation of the [REC] button.

[Setting Values: On, ●Off]

SD Aspect

For setting the style of displaying down-converted images on a 4:3 aspect ratio screen.

- Side Cut:
Displays image with the left and right sides cut off.
- Letter:
Displays as a wide image with the top and bottom blackened.
- Squeeze:
Displays image that is squeezed horizontally.

[Setting Values: Side Cut, Letter, ●Squeeze]

Memo : _____

- When [Record Format] → [System] is set to “SD” or “SD(SDI In)”, and when [SD Aspect] is set to “4:3”, this item appears as “---” and cannot be selected.
(P132 [System])
- When [Record Format] → [System] is set to “SD”, and [SD Aspect] is set to “16:9”, “Side Cut” in [A/V Set] → [Video Set] → [SD Aspect] cannot be selected.
(P125 [SD Aspect])
(P132 [System])

SD Set Up

For selecting whether to add a setup signal to the video signal output from the [VIDEO OUT] terminal. Setup signals are added when “7.5%” is selected. [Setting Values: 7.5%, 0.0%] (Default values: 7.5% (U model), fixed at “0.0%” (E model))

Memo : _____

- Depending on the menu settings of the camera recorder and the condition of the cable connected to it, the setup signal setting may be fixed at “0.0%”. “0.0%” is displayed in gray in this case.
- When [Main Menu] → [System] → [Record Set] → [Record Format] → [Frame & Bit Rate] is set to “50p” or “50i”, “---” is displayed and selection is disabled.

HDMI Out Character

For selecting whether to display the screen text and menu text on the output screen from the [HDMI] output terminal located at the side terminal section of the camera recorder. [Setting Values: On, ●Off]

SDI Out Character

For selecting whether to display the screen text and menu text on the output screen from the [HD/SD SDI OUT] terminal located at the side terminal section of the camera recorder. [Setting Values: On, ●Off]

VIDEO Out Character

For selecting whether to display the screen text and menu text on the output screen from the [VIDEO OUT] terminal located at the side terminal section of the camera recorder. [Setting Values: On, ●Off]

Genlock Input 890 890CH

For selecting the input destination of video synchronizing signals.

- SDI: Inputs video synchronizing signals from the [HD/SD SDI IN] terminal on the side.
- Adapter: Inputs video synchronizing signals from the adapter connected to the accessory connection terminal (68 pins) on the rear of the camera recorder.
- BNC: Inputs video synchronizing signals from the [GENLOCK] terminal on the side.

[Setting Values: SDI, Adapter, ●BNC]

Genlock Adjust

Adjusts the H Phase of the camera recorder’s video signals with respect to the input synchronizing signals.

↳ **Analog SD H Phase**

Adjusts the H Phase of the camera recorder’s SD analog signal with respect to the external synchronizing signal input to the terminal set in the [Genlock Input] item.

[Setting Values: -28 to +82] (● 0)

↳ **Analog HD H Phase** 890 890CH

Adjusts the H Phase of the camera recorder’s HD analog signal with respect to the external synchronizing signal input to the terminal set in the [Genlock Input] item.

[Setting Values: -1024 to +1023] (● 0)

↳ **SD-SDI H Phase**

Adjusts the H Phase of the camera recorder’s SD-SDI signal with respect to the external synchronizing signal input to the terminal set in the [Genlock Input] item.

[Setting Values: -373 to +373] (● 0)

Memo : _____

- When [A/V Set] → [Video Set] → [HDMI/SDI Out] → [Resolution] is set to “720p”/“1080i”/“1080p”, “---” is displayed and selection is disabled. (☞ P125 [Resolution])

↳ **HD-SDI H Phase**

Adjusts the H Phase of the camera recorder’s HD-SDI signal with respect to the external synchronizing signal input to the terminal set in the [Genlock Input] item.

[Setting Values: -1024 to +1023] (● 0)

Memo : _____

- When [A/V Set] → [Video Set] → [HDMI/SDI Out] → [Resolution] is set to “480i”/“480p”/“576i”/“576p”, “---” is displayed and selection is disabled. (☞ P125 [Resolution])

Return Input 890 890CH

For selecting the input destination of the return video.

- **SDI:**
Inputs return video from the [HD/SD SDI IN] terminal on the side.
- **Adapter:**
Inputs return video from the adapter connected to the accessory connection terminal (68 pins) on the rear of the camera recorder.
- **Studio:**
Inputs return video from studio adapter connected to the [STUDIO] terminal on the side.

[Setting Values: SDI, ●Adapter, Studio]

Memo : _____

- If this item is set to "SDI", the setting for [Camera Function] → [User Switch Set] → [Return Video] is fixed at "Camera > Return".

Return Aspect 890 890CH

For selecting the aspect ratio of the return video.

- **16:9:**
Select this option if the return video is a squeeze signal.
- **4:3:**
Select this option if the return video is a 4:3 aspect signal (including Letter Box).

[Setting Values: ●16:9, 4:3]

Audio Set Item**Input1 Mic Ref.**

For setting the reference input level when the [INPUT1] selection switch is set to "MIC" or "MIC +48V".

[Setting Values: -60dB, ● -50dB, -40dB, -30dB]

Input2 Mic Ref.

For setting the reference input level when the [INPUT2] selection switch is set to "MIC" or "MIC +48V".

[Setting Values: -60dB, ● -50dB, -40dB, -30dB]

AUX Gain

For setting the sensitivity of the [AUX] input terminal.

[Setting Values: +12dB, +6dB, ●0dB, -6dB, -12dB]

CH3/4 Input Level

For setting the mode and level of input to [CH-3] and [CH-4].

(P71 [For CH-3/CH-4])

CH1/2 Ref. Level

For setting the reference recording level of [CH-1] and [CH-2]. (Applies to both [CH-1] and [CH-2].)

[Setting Values: -12dB, -18dB, ●-20dB]

CH3/4 Ref. Level

For setting the reference recording level of [CH-3] and [CH-4]. (Applies to both [CH-3] and [CH-4].)

- **CH1/2 -12dB:**
Sets to a value that is 12dB lower than that of [CH-1] and [CH-2].
- **CH1/2 -6dB:**
Sets to a value that is 6dB lower than that of [CH-1] and [CH-2].
- **CH1/2 Link:**
Sets to the same value as [CH-1] and [CH-2].

[Setting Values: CH1/2 -12dB, CH1/2 -6dB, ●CH1/2 Link]

CH1/2 Limiter Mode

For setting whether to link the limiter operation of [CH-1] and [CH-2].

Select "Link" to link or "Separate" to separate.

[Setting Values: Link, ●Separate]

Memo : _____

- This option is selectable when both the [AUDIO SELECT CH-1] and [AUDIO SELECT CH-2] selection switches are set to "AUX", and the [AUDIO SELECT CH-1/CH-2 AUTO/MANUAL] selection switch is set to "AUTO" at the same time.
This option is selectable when the [AUDIO SELECT CH-1] selection switch is set to "INPUT1", the [AUDIO SELECT CH-2] selection switch is set to "INPUT2", and the [AUDIO SELECT CH-1/CH-2 AUTO/MANUAL] selection switch is set to "AUTO" at the same time.
In all other cases, it is fixed at "Separate".

CH1 Limiter/CH2 Limiter

Sets the limiter operation for [CH-1] and [CH-2] separately.

↳ **Threshold Level**

Sets the maximum recording level of [CH-1] and [CH-2] respectively.

[Setting Values: -17dBFS, -15dBFS, -12dBFS, -9dBFS, ● -6dBFS, Off]

↳ **Attack Time**

Sets the time to activate the limiter for [CH-1] and [CH-2] respectively.

[Setting Values: Fast, ●Middle, Slow]

↳ **Decay Time**

Sets the time to deactivate the limiter operation for [CH-1] and [CH-2] respectively.

[Setting Values: Fast, ●Middle, Slow]

CH3/4 Limiter Mode

For setting whether to link the limiter operation of [CH-3] and [CH-4].

Select "Link" to link or "Separate" to separate.

[Setting Values: Link, ●Separate]

Memo : _____

- This option is selectable when both the [AUDIO SELECT CH-3] and [AUDIO SELECT CH-4] selection switches are set to "AUX", and [Audio Set] → [CH3/4 Input Level] → [CH3]/[CH4] is set to "Auto" at the same time.
This option is selectable when the [AUDIO SELECT CH-3] selection switch is set to "INPUT1", the [AUDIO SELECT CH-4] selection switch is set to "INPUT2", and [Audio Set] → [CH3/4 Input Level] → [CH3]/[CH4] is set to "Auto" at the same time.
In all other cases, it is fixed at "Separate".
(P71 [For CH-3/CH-4])

CH3 Limiter/CH4 Limiter

Sets the limiter operation for [CH-3] and [CH-4] separately.

↳ **Threshold Level**

Sets the maximum recording level of [CH-3] and [CH-4] respectively.

[Setting Values: -17dBFS, -15dBFS, -12dBFS, -9dBFS, ● -6dBFS, Off]

↳ **Attack Time**

Sets the time to activate the limiter for [CH-3] and [CH-4] respectively.

[Setting Values: Fast, ●Middle, Slow]

↳ **Decay Time**

Sets the time to deactivate the limiter operation for [CH-3] and [CH-4] respectively.

[Setting Values: Fast, ●Middle, Slow]

CH1 Filter to CH4 Filter

For setting the input signals for [CH-1] to [CH-4] respectively to Wind Cut, Equalizer, or Off.
[Setting Values: Equalizer, Wind Cut, ●Off]

Memo : _____

- If the [AUDIO INPUT] signal selection switch 1 setting of [CH-1] in the [CH1 Filter] item is set to "LINE", "-" is displayed and selection is disabled.
- When [CH2 Filter] is set as follows, "-" is displayed and selection is disabled.
 - When [CH-2] is set to "INPUT1", and the [AUDIO INPUT] signal selection switch 1 setting is set to "LINE"
 - When [CH-2] is set to "INPUT2", and the [AUDIO INPUT] signal selection switch 2 setting is set to "LINE"
- If the [AUDIO INPUT] signal selection switch 1 setting of [CH-3] in the [CH3 Filter] item is set to "LINE", "-" is displayed and selection is disabled.
- When [CH4 Filter] is set as follows, "-" is displayed and selection is disabled.
 - When [CH-4] is set to "INPUT1", and the [AUDIO INPUT] signal selection switch 1 setting is set to "LINE"
 - When [CH-4] is set to "INPUT2", and the [AUDIO INPUT] signal selection switch 2 setting is set to "LINE"

Equalizer

You can correct the characteristic and enhance the sound of the connected microphone using this equalizer setting.

For setting the audio frequency from a 5-band equalizer.

- Frequency:
100Hz, 330Hz, 1kHz, 3.3kHz, 10kHz
- Variable level:
± 6dB (0.5dB step)

Memo : _____

- Audio will be recorded in the characteristic set in the equalizer.
- Set all bands to "0dB" to bypass the equalizer.
- When the equalizer level is set to the + side, the audio may be distorted. In this case, reduce the recording level in Manual mode.
- If the values of multiple frequencies are changed, the specified levels and the actual levels may be different due to interference between the frequency bands.
- Not selectable if none of the items from [CH1 Filter] to [CH4 Filter] is set to "Equalizer".

Output CH

For setting the channel to output to the [AUDIO OUTPUT] and [HDMI] terminals.

- CH3/4:
Outputs the audio of [CH-3] and [CH-4].
- CH1/2:
Outputs the audio of [CH-1] and [CH-2].
- SW Set:
Outputs according to the [MONITOR SELECT] switch setting.

[Setting Values: CH3/4, ●CH1/2, SW Set]

Monitor

For setting the audio sound of the [PHONES] terminal to stereo or mixed sound when the [MONITOR] selection switch at the handle section is set to "BOTH".

- Mix:
Outputs mixed sound (mixed sound of CH-1 and CH-2) to both L and R.
- Stereo:
Outputs stereo sound (outputs audio sound of CH-1 to L, and CH-2 to R).

[Setting Values: ●Mix, Stereo]

Alarm Level

For selecting whether to turn on the warning tone as well as setting the volume.

The warning tone is output from the monitor speaker or [PHONES] terminal.

[Setting Values: Off, 1 to 5] (●5)

Test Tone

For specifying whether to output the audio test signals (1 kHz) during color bar output.

[Setting Values: On, ●Off]

System Menu

This menu screen allows system-related settings. For specifying recording settings, formatting and restoring of SD card, tally lamp settings, network settings, date/time, time zone, and other settings. It can also be used to reset the menu settings to their default values.

Record Set...

For specifying recorded video-related settings.
(☞ P132 [Record Set Item])

Media

↳ Format Media

For formatting (initializing) an SD card.
(☞ P45 [Formatting (Initializing) SD Cards])

↳ Restore Media

Restores and updates the SD card.
(☞ P46 [Restoring and Updating the SD Card])

Memo : _____
• This option is not selectable in the Media mode.
• Executing this function while [!RESTORE] is not displayed updates the data inside the SD card.

Setup File

This allows you to save the menu settings as well as the performance results of shutter speed and AWB. It is useful to save settings according to different shooting conditions.

↳ Load File...

Loads the settings.
(☞ P158 [Loading a Setup File])

↳ Store File...

Saves the settings.
(☞ P157 [Saving Setup Files])

↳ Delete File...

Deletes the configured file.
(☞ P159 [Deleting Setup Files])

Tally System

For setting the display conditions of the tally lamp (front and back) on the camera recorder.

- Internal:
Displays mainly the status of the camera recorder.
- Studio:
Displays the TALLY IN/PREVIEW IN signals from an external device, such as a remote control unit.

[Setting Values: ●Internal, Studio]

Front Tally/Back Tally

For setting how the front and back tally lamps on this camera recorder are illuminated while recording is in progress, when a remaining level warning is displayed, and during live streaming. The selectable options vary according to the [Tally System] setting.

- When [Tally System] is set to “Internal”
 - Rec/Live Streaming:
Lights up when recording or live streaming is in progress.
 - Live Streaming:
Lights up when live streaming is in progress. Does not light up during recording.
 - Rec:
Lights up during recording.
 - Off:
Does not light up or blink.

[Setting Values: Rec/Live Streaming, Live Streaming, ●Rec, Off]

- When [Tally System] is set to “Studio”
 - On:
Lights up when there is tally input or preview input signal from an external device, such as a remote control unit.
 - Off:
Does not light up.

[Setting Values: ●On, Off]

Memo : _____
• The blinking warning display, such as when the remaining battery level is low, is enabled in a setting other than “Off”.

GPS GPS

For setting the GPS function to On or Off (power on/off).

[Setting Values: On, ●Off]

Language

Switches between languages in the menu screen.
[Setting Values: ●English, Français, Español] (U model)

[Setting Values: ●English, Français, Deutsch, Italiano, Español, Русский, 汉语] (E model)

Network

When using the network feature, set to “On(SDI Off)” or “On(HDMI Off)”.

- On(SDI Off):
Uses the network function. However, SDI output is disabled.
- On(HDMI Off):
Uses the network function. However, HDMI output is disabled.
- Off:
Does not use the network function.

[Setting Values: On(SDI Off), On(HDMI Off), ●Off]

Memo : _____

- Restriction applies to the following functions when you are using the network function.
 - SDI and HDMI cannot be output simultaneously.
 - [Variable Frame Rate] cannot be selected.
 - [Flash Band Correction] is fixed at “Off”.
 - [LCD + VF] is fixed at “Off”.

↳ Import Metadata

For importing metadata from the FTP server.

Memo : _____

- This option is not available when [Network] is set to “Off”.
- This option cannot be selected if network connection is not established.
(☞ P174 [Preparing Network Connection])
- This option is not selectable while FTP transfer is in progress.

↳ Settings...

For specifying network-related settings.

(☞ P137 [Network/Settings Item])

Memo : _____

- This option is not available when [Network] is set to “Off”.

System Frequency

For selecting the shooting frame rate.

Set to “60/30/24” to shoot at 60p, 60i, 30p, or 24p and to “50/25” to shoot at 50p, 50i, or 25p.

[Setting Values: 60/30/24, 50/25]

(Default values: 60/30/24 (U model), 50/25 (E model))

Reset All

Resets all menu settings.

Memo : _____

- [Date/Time] and [Time Zone] cannot be reset.
(☞ P131 [Date/Time])
(☞ P131 [Time Zone])
- This item is not selectable when recording in Camera mode, during Clip Review, and in Media mode.

Date/Time

For setting the year, month, day, hour, and minute.

Memo : _____

- For setting the time acquired from the GPS satellite by pressing the [OIS/1] button if radio wave reception from the GPS satellite allows for setting of the date and time.
The [OIS/1] button is grayed out if information for setting the date and time cannot be acquired from the GPS satellite. **GPS**
- The display order of the date (year, month, day) follows the setting in [Display Settings] ➔ [Date Style]. However, the 24-hour format is used for the hour display regardless of the [Time Style] setting.
(☞ P124 [Date Style])

Time Zone

For setting the UTC time difference in units of 30 minutes.

[Setting Values: UTC-12:00-UTC-00:30, UTC,

UTC+00:30-UTC+14:00 (in 30 min increments)]

(Default values: UTC-05:00 (U model), UTC (E model))

Memo : _____

- If [Date/Time] is already set, the [Date/Time] item is automatically adjusted when [Time Zone] is altered.

System Information

↳ Version(Camera)

Displays information on the firmware version.

↳ Version(Lens) LENS

Displays information on the version of the lens in use.

↳ Fan Hour

For displaying the usage time of the internal fan.

Memo : _____

- Under normal environment, dust will accumulate on the internal fan when the camera recorder is used over a long period. Dust may enter the camera recorder especially if it is used outdoors. This may affect the image and sound quality of the camera recorder. Check and replace the fan after every 9000 hours (suggested guideline).

↳ Open Source License

Displays the license for the open source software used by this camera recorder.

Record Set Item

Record Format

After setting of all items in the [Record Format] menu is complete, select [Set] at the bottom of the screen to apply the new settings on the camera recorder and switch the recording format. A “Please Wait...” message appears during switching.

↳ System

For selecting a system definition. Select from “HD” (High Definition), “SD” (Standard Definition), and “Web” (low bit rate for web use).

- HD: Records the camera video in “HD” to slot A and slot B.
- SD: Records the camera video in “SD” to slot A and slot B.
- HD+SD: Records the camera video in “HD” to slot A, and in “SD” to slot B.
- HD+Web: Records the camera video in “HD” to slot A, and in “Web” to slot B.
- HD(SDI In) **890 890CH**: Records the HD SDI video of the device connected to the [SDI IN] terminal in “HD” to both slot A and slot B.
- SD(SDI In) **890 890CH**: Records the SD SDI video of the device connected to the [SDI IN] terminal in “SD” to both slot A and slot B.

[Setting Values: ●HD, SD, HD+SD, HD+Web, HD(SDI In), SD(SDI In)]

Caution : _____

- The selectable options for the [A]Format], [A]Resolution], [A]Frame & Bit Rate], [B]Format], [B]Resolution], and [B]Frame & Bit Rate] settings vary depending on the setting of this item.
- When [System] → [System Frequency] is set to “50/25”, “SD”, “HD+SD”, and “SD(SDI In)” cannot be selected. (U model)
- When [System] → [System Frequency] is set to “60/30/24”, “SD”, “HD+SD”, and “SD(SDI In)” cannot be selected. (E model)

↳ **A Format**

For selecting the format of the file to be recorded to the SD card when [System] is set to "HD".

For selecting the format of the file to be recorded to the SD card in slot A.

(P50 [Possible Slot A Setting Combinations])

- QuickTime(MPEG2):
QuickTime file format (.MOV)
- MP4(MPEG2):
MP4 file format
- MXF(MPEG2):
MXF (material exchange format)
- AVCHD:
AVCHD file format
- QuickTime(H.264):
QuickTime format (.MOV)

[Setting Values: ●QuickTime(MPEG2), MP4(MPEG2), MXF(MPEG2), AVCHD, QuickTime(H.264)]

Memo : _____

- When [System] is set to "SD", this item is fixed at "QuickTime(H.264)".

↳ **A Resolution**

For selecting the image size to be recorded to the SD card in slot A. (Horizontal x vertical)

The available options vary according to the [AFormat] and [System] settings.

(P50 [Possible Slot A Setting Combinations])

[Setting Values: ●1920x1080, 1440x1080, 1280x720]

Memo : _____

- When [System] is set to "SD" or "SD(SDI In)", this item is fixed as follows.
 - U model: Fixed at "720x480"
 - E model: Fixed at "720x576"

↳ **A Frame & Bit Rate**

For selecting the recording frame rate and encoding bit rate for the SD card inserted into slot A.

The available options vary according to the settings for [System Frequency], [System], [AFormat], and [AResolution].

(P50 [Possible Slot A Setting Combinations])

[Setting Values: 60p (XHQ), 60i (XHQ), 60i (UHQ), 60p (HQ), 60i (HQ), 60p (SP), 60i (SP), 60i (LP), 60i (EP), 50p (XHQ), 50i (XHQ), 50i (UHQ), 50p (HQ), 50i (HQ), 50p (SP), 50i (SP), 50i (LP), 50i (EP), 30p (XHQ), 30p (UHQ), 30p (HQ), 25p (XHQ), 25p (UHQ), 25p (HQ), 24p (XHQ), 24p (UHQ), 24p (HQ)]

Memo : _____

- The recording bit rate (video) is 50 Mbps in "XHQ", 35 Mbps VBR in "UHQ" and "HQ", and 18.3 Mbps (25 Mbps in the case of 1080i) CBR in "SP".
- The recording bit rate (system rate) is as follows when [AFormat]/[BFormat] is set to "AVCHD".
 - "HQ(60p)" and "HQ(50p)": 28 Mbps VBR
 - "HQ(60i)" and "HQ(50i)": 24 Mbps VBR
 - "SP": 18 Mbps VBR
 - "LP": 9 Mbps VBR
 - "EP": 5 Mbps VBR
- When [System] is set to "SD" or "SD(SDI In)", this item is fixed as follows for the different models.
 - U model: "60i"
 - E model: "50i"

↳ **A Audio**

For selecting the audio to be recorded to slot A (2ch or 4ch). The selectable options vary according to the [AFormat] setting.

(P50 [Possible Slot A Setting Combinations])

[Setting Values: ●4ch, 2ch]

Memo : _____

- When [AFormat] is set to "AVCHD", this item is fixed at "2ch".

↳ **B Format**

For selecting the format of the file to be recorded to the SD card in slot B when [System] is set to “HD+Web” or “HD+SD”.

The selectable options vary according to the [System] setting.

(☞ P51 [Possible Slot B Setting Combinations])

[Setting Values: ●QuickTime(H.264), AVCHD]

Memo : _____

- When [System] is set to “HD+SD”, this item is fixed at “QuickTime(H.264)”.
- When [System] is set to “HD+Web” and [A]Frame & Bit Rate] is set to “30p”, “25p”, or “24p”, this item is fixed at “QuickTime(H.264)”.
- When [System] is set to “HD”, “SD”, “HD(SDI In)”, or “SD(SDI In)”, this item is fixed at the same setting as [A]Format].

↳ **B Resolution**

For selecting the size of the image to be recorded to the SD card in slot B when [System] is set to “HD+Web” or “HD+SD”. (Horizontal x vertical)

The available options vary according to the [System] and [B]Format] settings.

(☞ P51 [Possible Slot B Setting Combinations])

[Setting Values: ●960x540, 480x270]

Memo : _____

- When [System] is set to “HD”, “SD”, “HD(SDI In)”, or “SD(SDI In)”, this item is fixed at the same setting as [A]Resolution].
- When [System] is set to “HD+SD”, this item is fixed at “720x480”.
- When [System] is set to “HD+SD”, this item is fixed at “720x576”.
- When [System] is set to “HD+Web” and [B]Format] is set to “AVCHD”, this item is fixed at “1440x1080”.

↳ **B Frame & Bit Rate**

For selecting the frame rate and encoding bit rate of the image to be recorded to the SD card in slot B when [System] is set to “HD+Web” or “HD+SD”.

The available options vary according to the [System] and [A]Frame & Bit Rate] settings.

(☞ P51 [Possible Slot B Setting Combinations])

[Setting Values: 60i (LP), 60i (EP), 50i (LP), 50i (EP), 30p (HQ), 30p (LP), 25p (HQ), 25p (LP), 24p (HQ), 24p (LP)]

Memo : _____

- When [System] is set to “HD+SD”, this item is fixed at “60i”.
- When [System] is set to “HD+SD”, this item is fixed at “50i”.
- When [System] is set to HD+Web and [B]Format] is set to “QuickTime(H.264)”, this item is fixed at “30p”, “25p”, or “24p”.
- When [System] is set to “HD”, “SD”, “HD(SDI In)”, or “SD(SDI In)”, this item is fixed at the same setting as [A]Frame & Bit Rate].

↳ **B Audio**

The audio (2ch/4ch) to be recorded to slot B is the same as the audio to be recorded to slot A.

However, if [B]Format] is set to “AVCHD”, this item is fixed at “2ch”.

(☞ P51 [Possible Slot B Setting Combinations])

[Setting Values: ●4ch, 2ch]

Memo : _____

- When [System] is set to “HD”, “SD”, “HD(SDI In)”, or “SD(SDI In)”, this item is fixed at the same setting as [A]Frame & Bit Rate].

↳ SD Aspect

For setting the aspect ratio of the SD recording image when [System] is set to “HD+SD”, “SD”, or “SD(SDI In)”.

[Setting Values: ●16:9, 4:3]

Memo : _____

- When [System] is set to “HD”, “HD+Web”, or “HD(SDI In)”, this item is fixed at “16:9”.

Rec Mode

- For selecting the record mode for recording to the SD card.
(☞ P89 [Special Recording])
- The selectable options vary according to the [Record Format] menu settings.

Format	No. of Frames for Frame & Bit Rate	Setting values
MP4 (MPEG2) QuickTime (MPEG2) MXF (MPEG2)	30p, 25p, 24p	Normal, Pre Rec, Clip Continuous, Interval Rec, Frame Rec, Variable Frame
	60p, 60i, 50p, 50i	Normal, Pre Rec, Clip Continuous, Interval Rec, Frame Rec
AVCHD	50i, 60i	Normal, Pre Rec, Interval Rec, Frame Rec
QuickTime (H.264)	60p, 60i, 50p, 50i	Normal, Pre Rec, Clip Continuous, Interval Rec, Frame Rec
	30p, 25p, 24p	Normal, Pre Rec, Clip Continuous, Interval Rec, Frame Rec, Variable Frame

Memo : _____

- When [Slot Mode] is set to “Backup”, this item is fixed at “Normal”.
- [Variable Frame Rate] is enabled when [AResolution]/[BResolution] is set to “1920x1080” or “1280x720”, and the number of frames for [AFrame & Bit Rate]/[BFrame & Bit Rate] is set to 30p, 25p, or 24p.
- When [System] is set to “HD+SD”, “HD+Web”, “HD(SDI In)”, or “SD(SDI In)”, this item is fixed at “Normal”.
- When [Network] in the System menu is set to other than “Off”, and the KA-M790G (Multicore Remote Adapter: optional) is connected to the rear of the camera recorder and power is supplied from the 26-pin camera cable, “Variable Frame” is not selectable.

↳ Pre Rec Time

For setting the pre-recording time when [Rec Mode] is set to “Pre Rec”.

[Setting Values: ●5sec, 10sec]

↳ Rec Frames

For setting the number of frames to record when [Rec Mode] is set to “Frame Rec” or “Interval Rec”.

[Setting Values: ●1frame, 3frames, 6frames]

↳ Rec Interval

For setting the recording time interval when [Rec Mode] is set to “Interval Rec”.

[Setting Values: ●1sec, 2sec, 5sec, 10sec, 30sec, 1min, 2min, 5min, 10min, 30min, 1hour]

↳ Variable Frame Rate

For setting the frame rate during recording when [Rec Mode] is set to “Variable Frame”.

The available options vary according to the settings for [Record Format] → [AResolution]/ [BResolution] and [AFrame & Bit Rate]/[BFrame & Bit Rate].

(☞ P93 [Variable Frame Rec])

Slot Mode

For setting the operation of the card slot.

- **Series:**
Mode that activates the two slots sequentially.
- **Dual:**
Mode that activates the two slots at the same time.
(P85 [Dual Rec])
- **Backup:**
Mode that enables recording to slot B without using the [REC] button. This item is selectable only when [Rec Mode] is set to “Normal”.
Start or stop the recording using the [Backup Rec] menu, or by pressing the button among [USER1] to [USER10] that is assigned with “Backup Trig” together with the [RET] button on the lens.
(P87 [Backup Rec])

Memo : _____

- When this is set to “Series”, and recordable media are inserted in both slots, pressing the [REC] button starts recording only to the card in the selected slot (active slot).
- When “Series” is selected, and [Record Format] → [A Format] is set to “AVCHD”, the clips are recorded over the slots seamlessly without interruption in the video.
- When this is set to “Dual”, and recordable media are inserted in both slots, pressing the [REC] button starts simultaneous recording to the cards in both slots.

↳ Backup Rec

For starting/stopping backup recording with [REC]/[STBY].

This item is selectable only when [Slot Mode] is set to “Backup”.

Memo : _____

- When recording is stopped due to no remaining space on the media, etc., this item is fixed at “STOP” and cannot be selected.

4GB File Spanning(SDXC)

A recording file is automatically split when the size exceeds 4 GB, but if an SDXC card is used, you can record clips larger than 4 GB by setting this option to “Off”. (Up to a maximum of 64 GB or 4 hours)

- **On:**
Splits a file when it exceeds 4 GB or 30 minutes.
 - **Off:**
Splits a file when it exceeds 64 GB or 4 hours.
- [Setting Values: ●On, Off]

Memo : _____

- This option is only valid if the SD card used for recording is of the SDXC format.
- During simultaneous recording, such as Dual Rec and backup recording, this option is valid only when the SD cards in both slots are of the SDXC format.
- This option is valid only when [Record Format] → [A Format]/ [B Format] is set to “QuickTime(MPEG2)”, “MXF(MPEG2)”, or “QuickTime(H.264)”.
(P133 [Format])
(P134 [Format])

Recording in DCIM Folder

When “On” is selected, files are recorded to the DCIM folder of the SD card during MOV recording.
[Setting Values: ●On, Off]

Memo : _____

- When “Off” is selected, folders containing recorded clips may not be detectable in the MAC OS environment.
- To import clips to a Blu-ray disc & HDD recorder produced by our company, set this item to “Off” before recording.

Time Stamp

For setting whether to display shooting date/time information in the recorded video.

[Setting Values: On, ●Off]

Memo : _____

- The date/time display style can be changed in [LCD/VF] → [Display Settings] → [Date Style]/[Time Style].
(P124 [Date Style])
(P124 [Time Style])

- When the date/time is hidden while the menu screen, status screen or other screen is displayed, the date/time during this period will not be recorded to the video. A confirmation screen appears if you try to display the menu screen or status screen during recording.
- When [System] is set to “HD+Web” or “HD+SD”, the shooting date/time information cannot be recorded to the image to be recorded in slot B.
- When [Record Format] → [System] is set to “HD(SDI In)” or “SD(SDI In)”, [Time Stamp] cannot be set to “On”.

Clip Set

↳ Clip Name Prefix

For setting the first four characters of the name of the clip file to be recorded to the SD card. Enter any of the 38 characters including alphabets (upper case), numbers (0 to 9), “_” (underscore), and “-” (hyphen) using the software keyboard.

(P105 [Text Input with Software Keyboard])
[Setting Values: xxxG] (The default value of xxx is the last three digits of the serial number.)

Memo : _____

- When [Main Menu] → [System] → [Record Set] → [Record Format] → [A]Format is set to “AVCHD”, this setting is not reflected in the file name of the clip. However, it is recorded as the display name of the clip in the thumbnail display.

↳ Reset Clip Number

For assigning a new number (Clip Number) by resetting it (0001).
Select [Reset] and press the Set button (●) to reset the number.

When [A]Format is set to “AVCHD”, the clip number is reset to “00000”.

When other clips exist on the SD card, the smallest available number is used after reset.

- Example:
If the [Clip Name Prefix] is “ABCD”, and “ABCD0001” already exists on the SD card, “ABCD0002” will be assigned.

Clear Planning Metadata

Erases the planning metadata downloaded from the FTP server.

Network/Settings Item

For specifying network-related settings.
The display of the software keyboard for input varies according to the item you are setting.
(P105 [Text Input with Software Keyboard])

Web

For setting the functions that make use of the web browser.

↳ Web Access

To access via a web browser, set to “On”.
[Setting Values: ●On, Off]

↳ Camera Name

For setting the name displayed on the web browser. Enter not more than 8 characters using the software keyboard.

- Default value:
HM890 **890** **890CH**
HM850 **850** **850CH**

↳ Login Name (Fixed)

The login name is “prohd”. It cannot be changed.

↳ Login Password

Changes the password for accessing via a web browser.
The current password is displayed. Enter a new password directly.
Enter not more than 31 characters using the software keyboard.

Live Streaming Set

For specifying settings for distributing live video images.

Memo : _____

- Users cannot access this menu in the following cases.
 - When [Record Format] → [System] is set to “HD+SD” or “HD+Web”
 - When [Record Format] → [Frame & Bit Rate] is set to “24p”

↳ Live Streaming

Starts live distribution when “On” is selected.

[Setting Values: On, ●Off]

Memo : _____

- “On” cannot be selected if network connection is not established.
- “On” cannot be selected when FTP is running.
- Live streaming switches to “Off” when the power is turned off.

↳ Resolution

For setting the resolution of the video image during live distribution.

The camera recorder restarts when the setting is changed.

The available options vary according to the settings for [AResolution] and [AFrame & Bit Rate] under [Record Format].

A Resolution	No. of Frames for AFrame & Bit Rate	Setting values (●: default value)
1920x1080, 1440x1080	60p, 60i, 30p	●1920x1080, 1280x720, 720x480, 480x270
	50p, 50i, 25p	●1920x1080, 1280x720, 720x576, 480x270
1280x720	60p, 30p	●1280x720, 720x480, 480x270
	50p, 25p	●1280x720, 720x576, 480x270
720x480 (U model)	60i	720x480, 480x270
720x576 (E model)	50i	720x576, 480x270

Memo : _____

- The settings cannot be changed during live streaming or recording.
- When [System] ⇒ [Record Set] ⇒ [Record Format] ⇒ [SD Aspect] is set to “4:3”, the aspect ratio of the live streaming image becomes “4:3”.

↳ Frame & Bit Rate

For setting the frame rate and encoding bit rate of the video image during live distribution.

The available options vary according to the settings for [Resolution] above, as well as [AFrame & Bit Rate] under [Record Format].

No. of Frames for AFrame & Bit Rate	Resolution	Setting values (●: default value)
60p, 60i, 30p	1920x1080	●60i (8.0M), 60i (5.0M), 60i (2.5M)
	1280x720	●30p (5.0M), 30p (3.0M), 30p (1.5M)
	720x480	60i (5.0M), ●60i (3.0M), 60i (1.5M), 60i (0.8M), 60i (0.3M), 60i (0.2M)
	480x270	30p (0.2M)
50p, 50i, 25p	1920x1080	●50i (8.0M), 50i (5.0M), 50i (2.5M)
	1280x720	●25p (5.0M), 25p (3.0M), 25p (1.5M)
	720x576	50i (5.0M), ●50i (3.0M), 50i (1.5M), 50i (0.8M), 50i (0.3M), 50i (0.2M)
	480x270	25p (0.2M)

Memo : _____

- The settings cannot be changed during live streaming.
- An encoding bit rate exceeding 5.0 Mbps cannot be selected when [Type] is set to “RTSP/RTP”.
- An encoding bit rate exceeding 3.0 Mbps cannot be selected when [Type] is set to “ZIXI”.

↳ Type

For setting the system to transfer videos for distribution.

[Setting Values: ●MPEG2-TS/UDP, MPEG2-TS/TCP, RTSP/RTP, ZIXI]

Memo : _____

- Use reception devices that are compatible with the respective transfer systems.
- To use the "ZIXI" setting, a dedicated server is needed separately.

↳ UDP/TCP Settings

For specifying the settings that are enabled only when [Type] is set to "MPEG2-TS/UDP" or "MPEG2-TS/TCP".

Memo : _____

- The settings cannot be changed during live streaming.

■ Destination Address

For setting details such as the host name and the IP address of the live distribution destination.

- * Enter not more than 127 characters using single-byte alphanumeric characters (a to z, 0 to 9), single-byte hyphen [-], or dot [.]

■ Destination Port

Enter the network port number of the live distribution destination using an integer between 1 and 65535.

The default value is 6504.

↳ RTSP/RTP Settings

For specifying the settings that are enabled only when [Type] is set to "RTSP/RTP".

Memo : _____

- The settings cannot be changed during live streaming.

■ Password

Changes the password for RTSP authentication to enable client access. The current password is displayed. Enter a new password directly.

There is no default value (blank).

- * Enter not more than 31 characters.

↳ ZIXI Settings

For specifying the settings that are enabled only when [Type] is set to "ZIXI".

Memo : _____

- The settings cannot be changed during live streaming.

■ Destination Address

For setting details such as the host name and the IP address of the live distribution destination.

- * Enter not more than 127 characters using single-byte alphanumeric characters (a to z, 0 to 9), single-byte hyphen [-], or dot [.]

■ Destination Port

Enter the network port number of the live distribution destination using an integer between 1 and 65535.

The default value is 2088.

■ Stream ID

For setting the registered stream ID of the live distribution destination.

The default value varies with the product model.

- * Enter not more than 63 characters.

■ Password

For setting the [Stream ID] password.

There is no default value (blank).

- * Enter not more than 127 characters.

■ Latency

For setting the latency mode.

[Setting Values: Medium, ●Low]

Connection Setup

For specifying the settings for connecting to the network.

A [Wizard] screen will appear according to the adapter connected to the rear [HOST] terminal. Follow the instructions to perform the setting. You can Store, Load, and Delete the settings specified on the [Wizard] screen.

↳ Wizard

A [Wizard] appears according to the adapter connected to the rear [HOST] terminal.

Follow the instructions on the screen to perform setting.

↳ Load

Loads the settings on the [Wizard] screen.

(☞ P198 [Reading the Connection Settings File])

↳ Store

Saves the settings on the [Wizard] screen.

(☞ P197 [Saving the Connection Settings File])

↳ Delete

Deletes the saved settings.

(☞ P199 [Deleting Connection Settings])

Metadata Server

For registering the FTP server for importing the metadata and the path of the file to be imported. Up to 4 settings can be registered.

↳ Meta-FTP1 to Meta-FTP4 (The name that is specified in the respective [Alias] items is displayed.)

■ Alias

For setting a name to distinguish the settings of this camera recorder.

The name set in this item will be displayed in the [Import Metadata] options.

* Enter not more than 31 characters.

■ Protocol

For setting the protocol of the FTP server to be connected.

- FTP:
Protocol that does not encrypt the incoming and outgoing data.
- SFTP:
Protocol that encrypts incoming and outgoing data using SSH.
- FTPS:
Protocol that encrypts incoming and outgoing data using SSL or TLS. It uses an implicit mode (starts encrypted communication once connection starts).
- FTPES:
Protocol that encrypts incoming and outgoing data using SSL or TLS. It uses an explicit mode (starts encrypted communication after permission is granted).

[Setting Values: ●FTP, SFTP, FTPS, FTPES]

■ Server

For setting the server name ("mystation.com", etc.) or the IP address ("192.168.0.1", etc.) of the FTP server.

* Enter not more than 127 characters using single-byte alphanumeric characters (a to z, 0 to 9), single-byte hyphen [-], or dot [.]

■ Port

Enter the FTP server port number to use using an integer between 1 and 65535.

The default value varies with the Protocol setting. (FTP: 21, SFTP: 22, FTPS: 990, FTPES: 21)

■ File Path

Enter the path name for the metadata file ("/pub/meta.xml", "/home/user/meta2.xml", etc.)

* Enter not more than 127 characters.

■ Username

Enter the user name for connecting to the FTP server.

* Enter not more than 31 characters.

■ Password

Enter the password for connecting to the FTP server.

* Enter not more than 31 characters.

■ PASV Mode

For setting whether to set the communication mode used for file transfer to the passive mode.

Set to "On" if the camera is inside a firewall, and a connection from the FTP server to the camera cannot be established.

[Setting Values: On, ●Off]

Memo : _____

- When [Protocol] is set to "SFTP", this item appears as "---" and cannot be selected.

Clip Server

For setting the server and directory for uploading recorded clips in the SD card to the FTP server.

↳ Clip-FTP1 to Clip-FTP4 (The name that is specified in the respective [Alias] items is displayed.)

■ Alias

For setting a name to distinguish the settings of this camera recorder.

The name set in this item will appear on the [FTP Upload] action screen of the thumbnail display.

* Enter not more than 31 characters.

■ Protocol

For setting the protocol of the FTP server to be connected.

- FTP:
Protocol that does not encrypt the incoming and outgoing data.
- SFTP:
Protocol that encrypts incoming and outgoing data using SSH.
- FTPS:
Protocol that encrypts incoming and outgoing data using SSL or TLS. It uses an implicit mode (starts encrypted communication once connection starts).
- FTPES:
Protocol that encrypts incoming and outgoing data using SSL or TLS. It uses an explicit mode (starts encrypted communication after permission is granted).

[Setting Values: ●FTP, SFTP, FTPS, FTPES]

■ Server

For setting the server name (“mystation.com”, etc.) or the IP address (“192.168.0.1”, etc.) of the FTP server.

- * Enter not more than 127 characters using single-byte alphanumeric characters (a to z, 0 to 9), single-byte hyphen [-], or dot [.]

■ Port

Enter the FTP server port number to use using an integer between 1 and 65535.

The default value varies with the Protocol setting. (FTP: 21, SFTP: 22, FTPS: 990, FTPES: 21)

■ Dir. Path

Enter the path name for the directory to upload to (“/pub”, “/home/user”, etc.)

- * Enter not more than 127 characters.

■ Username

Enter the user name for connecting to the FTP server.

- * Enter not more than 31 characters.

■ Password

Enter the password for connecting to the FTP server.

- * Enter not more than 31 characters.

■ PASV Mode

For setting whether to set the communication mode used for file transfer to the passive mode.

Set to “On” if the camera is inside a firewall, and a connection from the FTP server to the camera cannot be established.

[Setting Values: On, ●Off]

Memo : _____

- When [Protocol] is set to “SFTP”, this item appears as “---” and cannot be selected.

Reset Network

Restores all items in the [Network] menu to their default settings.

Adding/Editing Frequently Used Menu Items

You can select and add/edit frequently used menu items freely to create a personal menu screen (Favorites Menu).

Memo : _____

- [Favorites Menu] is only enabled in the Camera mode. [Favorites Menu] remains unchanged even when the recording format changes.
- When [Main Menu] → [System] → [Record Set] → [Record Format] → [System] is set to “HD(SDI In)” or “SD(SDI In)”, [Favorites Menu] is disabled.
- Up to 20 menu items can be added.
- Added items in [Favorites Menu] will not be reset even when [Main Menu] → [Reset All] is executed.
- Long descriptive names may be displayed for the menu items in [Favorites Menu] to enable better understanding.

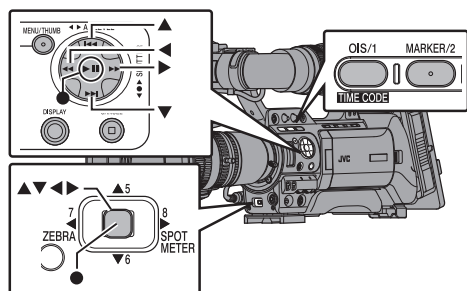

Registration to Favorites Menu

- 1 Press the [MENU/THUMB] button to open the [Main Menu] screen.
- 2 Select the menu or submenu item to add.

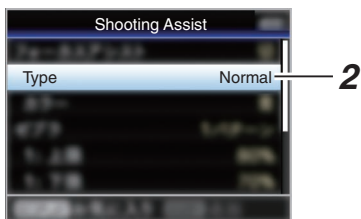

Memo : _____

- Adding items to [Favorites Menu] cannot be performed in the following cases. [USER1 Add] is displayed in gray in the operation guide.
 - Selected item is already added to [Favorites Menu].
 - Number of menu items that can be added (20 items) is exceeded.

- 3 Press the [OIS/1] button.
A screen to confirm the addition appears.
- 4 Select [Add] and press the Set button (●).
The selected menu item is added to [Favorites Menu].

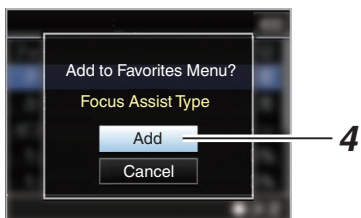

Editing Favorites Menu

You can delete or change the order of the items added to [Favorites Menu].

Deleting Items from [Favorites Menu]

1 Open the [Favorites Menu] screen.

- 1 Press the [MENU/THUMB] button to open the [Main Menu] screen.
- 2 Press the [DISPLAY] button or press and hold down the [MENU/THUMB] button to open the [Favorites Menu] screen.

2 Select [Edit Favorites] and press the Set button (●) or crossed-shaped button (▶).

The header turns magenta and the editing mode is activated.

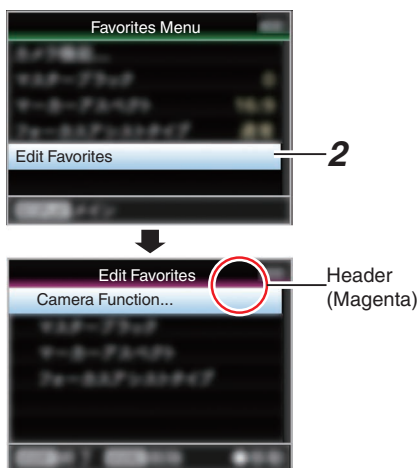

3 Select the menu or submenu item to delete.

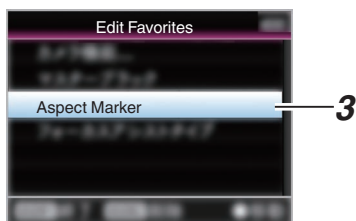

4 Press the [MARKER/2] button.

A delete mark (X) appears at the beginning of the menu item.

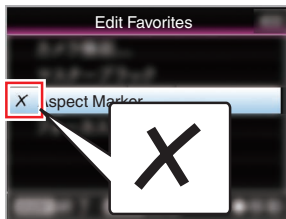

Memo : _____

- When the [MARKER/2] button is pressed again while the menu item with the delete mark (X) is selected, the menu item will be excluded from the items to be deleted and the delete mark (X) disappears.

5 Press the [OIS/1] button.

The option menu to exit the [Favorites Menu] editing mode appears.

6 Select [Save & Exit] and press the Set button (●).

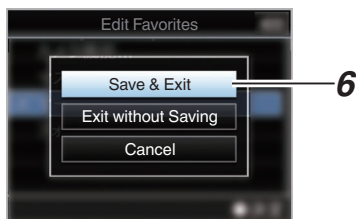

Memo : _____

- Deletion is not complete until the changes are saved with [Save & Exit].
- To exit the editing mode without deleting any items, select [Exit without Saving].
- To return to the editing mode, select [Cancel].

Changing the Order of Items in [Favorites Menu]

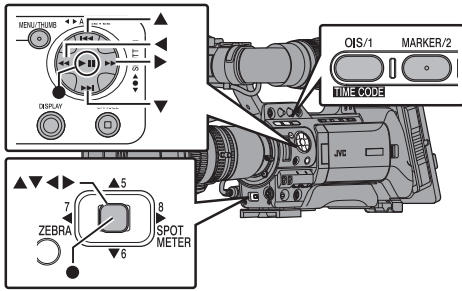

- 1 **Open the [Favorites Menu] screen.**
Press the [MENU/THUMB] button to open the [Favorites Menu] screen.
- 2 **Select [Edit Favorites] and press the Set button (●) or crossed-shaped button (▶).**
The header turns magenta and the editing mode is activated.

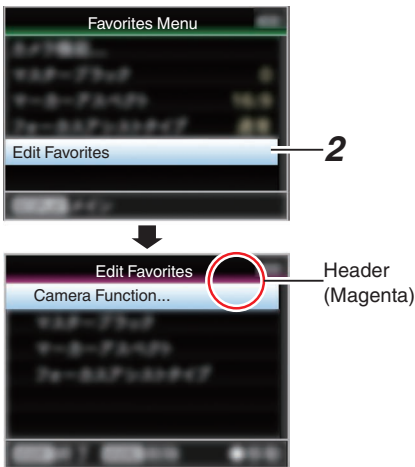

- 3 **Select the menu or submenu item to move and press the Set button (●).**
The moving mode is activated and a position selection bar for the move appears.

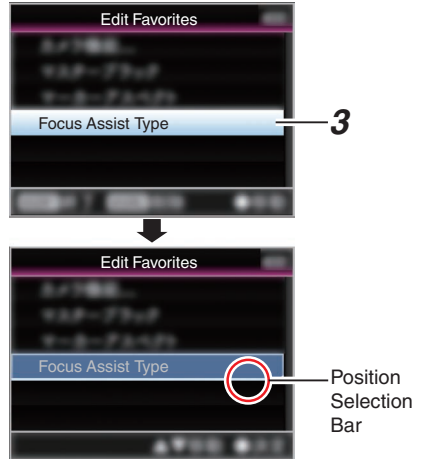

- 4 **Select the position to move to with the cross-shaped button (▲▼).**
Move the position selection bar with the cross-shaped button (▲▼) and select a position to move to.
- 5 **Press the Set button (●).**
The selected item moves to the new position.

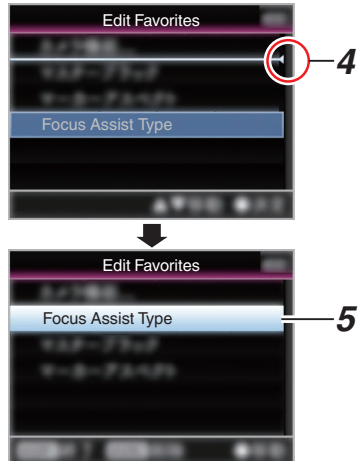

- 6 Press the [OIS/1] button.
The option menu to exit the [Favorites Menu] editing mode appears.
- 7 Select [Save & Exit] and press the Set button (●).

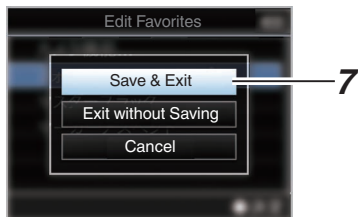

Memo : _____

- Moving is not complete until the changes are saved with [Save & Exit].
- To exit the editing mode without saving any changes, select [Exit without Saving].
- To return to the editing mode, select [Cancel].

Display Screen in Camera Mode

Display 0 screen

This screen displays the event. It is also used to display warnings only.

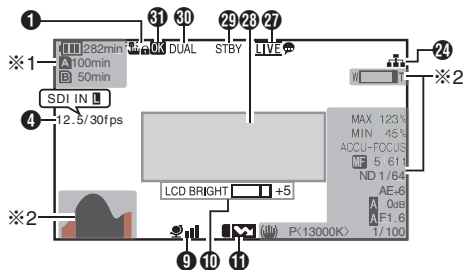

- *1 Appears only during warnings
- *2 Appears only during operation

Display 1 screen

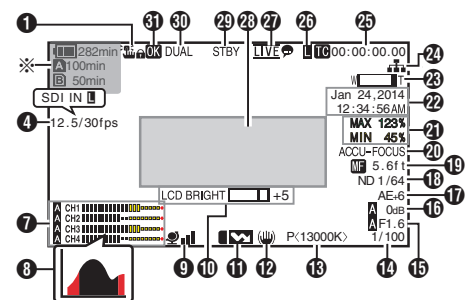

- * Appears only during warnings

Display 2 screen

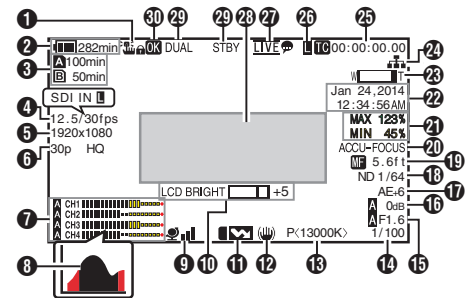

- 1 **Operation Lock Icon**
Appears when the operation lock feature is turned on.
(☞ P48 [About the Operation Lock Feature])
- 2 **Voltage/Battery Power**
Displays the current status of the power supply in use.
(☞ P32 [Power Status Display])

Memo : _____



- Displayed in the Display 0 and Display 1 screens during warnings only.

- 3 **Remaining Space on Media**
Displays the remaining recording time of the SD cards in slot A and slot B separately.

- A** : Currently selected slot. (White card)
- A**  : Write-protect switch of SD card is set.
- A!**INVALID : SD card cannot be read or written to, or restored.
- A!**FORMAT : SD card requires formatting.
- A!**RESTORE : SD card requires restoring.
- A!**INCORRECT :
 - When [Rec Mode] is set to other than “AVCHD”/“SD”/“Web” with a Class 4 SD card inserted.
 - When the SD card is not supported.
- A!**REC INH :
 - When attempting to record in 50p or 50i to an SD card recorded in [AVCHD]60p or 60i (or vice versa).
 - When attempting to record more than 4 GB while a media that does not support recording of more than 4 GB is inserted. (☞ P136 [4GB File Spanning(SDXC)])
 - When an SD card lower than Class 10 is inserted while in the XHQ mode.

The following icons are displayed during FTP upload.

(☞ P180 [Uploading a Recorded Video Clip])

Icon	Status
	FTP transfer is in progress. Three images are alternately displayed, and the arrows become animated. In this case, instead of the recordable time of the SD card, an estimated value of the remaining transfer time is displayed.
 (Yellow)	Error has occurred during FTP transfer.

- Memo : _____
- This item is not displayed when [Main Menu] → [LCD/VF] → [Display Settings] → [Media Remain] is set to “Off”. However, warnings will be displayed.
(☞ P123 [Media Remain])
 - Displayed on the Display 0 and Display 1 screens only in the case of warnings. (When the remaining time is shorter than 3 minutes)
The icons appear on all display screens in the following cases.
 - When recording is performed to only one of the slots while [Main Menu] → [System] → [Record Set] → [Slot Mode] is set to “Dual”.
(☞ P136 [Slot Mode])
 - When recording is performed to only one of the slots while [Main Menu] → [System] → [Record Set] → [Record Format] → [System] is set to “HD+SD” or “HD+Web”.
(☞ P132 [System])
 - The displayed time is an estimate.

- 4 **Frame rate** **850** **850CH**
Frame rate/SDI IN **890** **890CH**
 - Displayed as xx/yy fps (xx: recording frame rate, yy: playback frame rate) only when [Rec Mode] is set to “Variable Frame”.
(☞ P135 [Rec Mode])
 - “SDI IN ” is displayed when a device is connected to the [SDI IN] terminal, and [System] → [Record Set] → [Record Format] → [System] is set to “HD(SDI In)” or “SD(SDI In)”.
(☞ P132 [System])

5 Resolution

Displays the video image resolution.

Memo : _____

- This item is not displayed when [Main Menu] → [LCD/VF] → [Display Settings] → [Record Format] is set to “Off”.
(☞ P122 [Record Format])

6 Frame Rate/Bit Rate

Displays the frame rate and bit rate in pairs.

Memo : _____

- This item is not displayed when [Main Menu] → [LCD/VF] → [Display Settings] → [Record Format] is set to “Off”.
(☞ P122 [Record Format])

7 Audio Level Meter

- Displays the audio levels for CH-1 to CH-4.
- **A** appears on the screen when in the Auto mode.



- When [Rec Mode] → [Rec Mode] is set to “Frame Rec”, “Interval Rec”, or “Variable Frame”, audio cannot be recorded and the audio level meter is grayed out.



Memo : _____

- This item is not displayed when [Main Menu] → [LCD/VF] → [Display Settings] → [Audio Meter] is set to “Off”.
(☞ P123 [Audio Meter])

8 Histogram Display

This item is displayed when [Main Menu] → [LCD/VF] → [Display Settings] → [Histogram] is set to “On”.

(☞ P123 [Histogram])

Memo : _____

- When the histogram is displayed, the audio level meter display is turned off temporarily.

9 GPS Mark **GPS**

When [Main Menu] → [System] → [GPS] is set to “On”, the signal reception status is displayed.
(☞ P130 [GPS **GPS**])

Memo : _____

- The display changes according to the signal reception sensitivity. If signals cannot be received, the  mark appears in yellow.
- This item is not displayed when [GPS] is set to “Off”.

10 Volume Operation Indicator

This item is displayed when the LCD BRIGHT and LCD PEAKING values (-10 to +10) are changed.



11 Flash Band Correction Mark

This item is displayed when [Main Menu] → [Camera Function] → [Flash Band Correction] is set to “On”.

(☞ P108 [Flash Band Correction])

12 Image Stabilizer Icon **LENS**

Displayed when the image stabilizer is ON.

 : When [Level] of [OIS] is set to “Normal”.

 : When [Level] of [OIS] is set to “High”.

Memo : _____

- If image stabilizer is set to “OFF” when the Display 0 screen is displayed,  appears for 3 seconds.
- Displayed in the Display 0 screen only when there is a change.

13 White Balance Mode

Displays the current white balance mode.
(****K indicates color temperature)

A<****K> : When the white balance is set to Auto A.

B<****K> : When the white balance is set to Auto B.

P<****K> : When the white balance is set to Preset.

A<FAW> : During Full Auto White Balance mode.

L<FAW> : When [AE LOCK] is set to "On" during Full Auto White Balance mode.

Memo : _____

- Displayed in the Display 0 screen only when there is a change.

14 Shutter

- The current shutter speed is displayed when the shutter is set to "On".

(☞ P108 [Shutter])

- **A** is displayed when the [FULL AUTO] switch is set to "ON" to enable Full Auto shooting mode, or when the [SHUTTER] button is pressed to enable automatic shutter mode.

Memo : _____

- The variable range of the shutter speed varies according to the video format settings.
(☞ P60 [Setting the Electronic Shutter])
- Displayed in the Display 0 screen only when there is a change.
- If the shutter speed is not displayed, the shutter is OFF.

15 Iris F-Number

Displays F-number of the lens iris.

16 Gain

- Displays the gain value.
- **A** is displayed in the ALC mode during Manual shooting.
- **L** is displayed when AE LOCK is set to "ON".
- "LUX30" or "LUX36" is displayed when in the low-light shooting mode.

Memo : _____

- Displayed in the Display 0 screen only when there is a change.

17 AE Level

- Appears when the AE function is activated, and [Main Menu] → [Camera Function] → [AE Level] is set to a value other than "Normal".
(☞ P109 [AE Level])

- When operated while manual operation is disabled, "AE" blinks for about 5 seconds.

- When face detection is enabled and [Face Detect] is set to "AF&AE",  appears on the left side of "AE".

(☞ P56 [Adjusting the Focus by Face Detection **LENS**])

18 ND Filter Position

Displays the current ND filter position.

Memo : _____

- This item is not displayed when [Main Menu] → [LCD/VF] → [Display Settings] → [ND Filter] is set to "Off".

(☞ P122 [ND Filter])

- Displayed in the Display 0 screen only when there is a change.

19 Focus Display **LENS**

- Displays the approximate distance to the subject in focus during manual focus.

- **AF** is displayed during Auto Focus.

- When face detection is enabled,  appears on the left side of **AF**.

(☞ P56 [Adjusting the Focus by Face Detection **LENS**])

(☞ P112 [Face Detect **LENS**])

- If [Main Menu] → [Camera Function] → [AF Assist] is set to "Area", the  icon appears on the left side of **AF**.

(☞ P110 [AF Assist **LENS**])

Memo : _____

- You can specify the display method (Feet/ Meter) in [Main Menu] → [LCD/VF] → [Display Settings] → [Focus].

This item will not be displayed when "Off" is selected.

(☞ P122 [Focus **LENS**])

- Displayed in the Display 0 screen only when there is a change.

- 20** Focus Assist
- “FOCUS” is displayed when auto focus is activated.
 - When ACCU-Focus is enabled, “ACCU-FOCUS” blinks for about 10 seconds while Focus Assist starts up, after which the “FOCUS” indicator lights up.
 - If recording starts while [ACCU-Focus] is active, [ACCU-Focus] will be forcibly deactivated.
(☞ P121 [Focus Assist])

Memo : _____

- Displayed in the Display 0 screen only when there is a change.

- 21** Luminance Information
- Displayed when the Spot Meter function is activated.
(☞ P80 [Setting Spot Meter])
- MAX : Maximum luminance
MIN : Minimum luminance

- 22** Date/Time Display
- Displays the current date and time.

Memo : _____





- The date/time display style can be specified in [Main Menu] → [LCD/VF] → [Display Settings] → [Date Style]/[Time Style].
(☞ P124 [Date Style])
(☞ P124 [Time Style])
- This item is not displayed when [Main Menu] → [LCD/VF] → [Display Settings] → [Date/Time] is set to “Off”.
(☞ P124 [Date/Time])
- When [Main Menu] → [System] → [Record Set] → [Time Stamp] is set to “On”, this item is not displayed.
(☞ P136 [Time Stamp])

- 23** Zoom Display
- Displays the zoom position. (Zoom bar or value)
 - The zoom bar will only be displayed for 3 seconds after the zoom operation is activated.
 - The value will always be displayed. (0 to 99)

Memo : _____

- You can specify the display method (Number/Bar) in [LCD/VF] → [Display Settings] → “Zoom”. This item will not be displayed when “Off” is selected.
(☞ P122 [Zoom **LENS**])
- Displayed in the Display 0 screen only when there is a change.

- 24** Network Connection Icon
- When [Main Menu] → [System] → [Network] is set to “On(SDI Off)” or “On(HDMI Off)”, the network connection status is displayed. This icon is not displayed when “Off” is selected.
(☞ P131 [Network])

Icon	Status
 (Blink)	Connection is not established (starting up, preparing for connection)
 (Yellow)	Connection is not established (preparing for connection)
	Connection is established
	When a USB adapter different from the connection settings is detected
(No display)	When an incompatible USB adapter is detected, or when [Network] is set to “Off”

Memo : _____

- When a cellular adapter that supports LTE connection display is in use, “LTE” will appear to the left of the above icon when LTE connection is detected.

- 25** Time Code (TC)/User’s Bit (UB) Display
- Displays the time code (hour: minute: second: frame) or user’s bit data recorded in the SD card being played back.
 - Example of time code display:

TC00:00:00:00

⌋
※

- * Colon (:) denotes non-drop frames and dot (.) denotes drop frames.

- Example of user’s bit display:



UBFF EE DD 20

Memo : _____

- You can specify whether to display the time code, user's bit, or turn off the display in [LCD/ VF] → [Display Settings] → [TC/UB]. This item will not be displayed when "Off" is selected.
(☞ P123 [TC/UB])

26 Time Code Lock Indicator
When the built-in time code generator is synchronized to the external time code data input during the synchronization of time code with another camera recorder, **[L]** lights up.
(☞ P78 [Synchronizing the Time Code with an External Time Code Generator])

27 Live streaming mark
When [Main Menu] → [System] → [Network]/ [Settings] → [Live Streaming Set] → [Live Streaming] is set to "On", the distribution status is displayed.
(☞ P138 [Live Streaming])

Icon	Status
 (Red)	<ul style="list-style-type: none"> Distribution in progress (good connection quality) Blinks when distribution starts or stops
 (Red)	Distribution in progress (poor connection quality)
 (Yellow)	Waiting for connection (during RTSP/RTP) or connection failed

28 Event/Warning Display Area
Displays error messages.
(☞ P202 [Error Messages and Actions])

29 Media Status
---- : A card is not detected in the selected slot, and [Tally System] is also not set to "Studio"

- (☞ P130 [Tally System])
- STBY : Recording standby
 - REC : Recording
 - REVIEW : Clip Review
(☞ P83 [Viewing Recorded Videos Immediately (Clip Review)])
 - STBY **[P]** : Pre Rec recording standby
(☞ P89 [Pre Rec])
 - REC **[P]** : Pre Rec recording
(☞ P89 [Pre Rec])
 - STBY **[C]** : Clip Continuous Rec recording standby
(☞ P89 [Clip Continuous Rec])

- REC **[C]** : Clip Continuous Rec recording
(☞ P89 [Clip Continuous Rec])
- STBY **[C]** : Clip Continuous Rec recording (displayed in pause yellow)
(☞ P89 [Clip Continuous Rec])
- STBY **[I]** : Interval Rec recording standby
(☞ P92 [Interval Rec])
- STBY **[I]** : Interval recording pause (displayed in red)
- REC **[I]** : Interval Rec recording
(☞ P92 [Interval Rec])
- STBY **[F]** : Frame Rec recording standby
(☞ P91 [Frame Rec])
- REC **[F]** : Frame Rec recording
(☞ P91 [Frame Rec])
- STBY **[F]** : Frame Rec recording pause (displayed in yellow)
(☞ P91 [Frame Rec])
- STOP : Unable to record to the card in the slot
- P.OFF : Power OFF
- ✂ : During clip cutter recording (displayed for 3 seconds)
(☞ P85 [Splitting the Clips Freely (Clip Cutter Trig)])
- CALL : Receiving call signals from an external device, such as a remote control unit
- PGM : Receiving program signals from an external device, such as a remote control unit
- PVW : Receiving preview signals from an external device, such as a remote control unit

30 Dual Rec/Backup Rec Display
"DUAL" is displayed in the Dual Rec mode and "BACKUP" is displayed in the Backup Rec mode.
(☞ P136 [Slot Mode])

Memo : _____

- This item is not displayed when [Slot Mode] is set to "Series".
- This item is not displayed when [Main Menu] → [LCD/VF] → [Display Settings] → [Media Remain] is set to "Off". However, warnings will be displayed.
(☞ P123 [Media Remain])

31 OK Mark
Displayed when OK mark has been appended.
(☞ P99 [Appending/Deleting OK Mark])

Display Screen in Media Mode

Media Display 0 Screen

This screen displays the media status or event. It is also used to display warnings only.

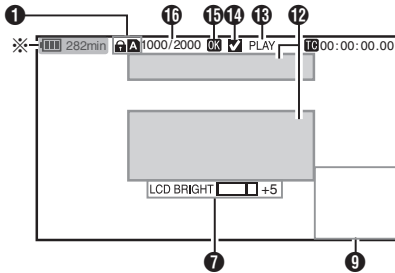

* Appears only during warnings

Media Display 1 Screen

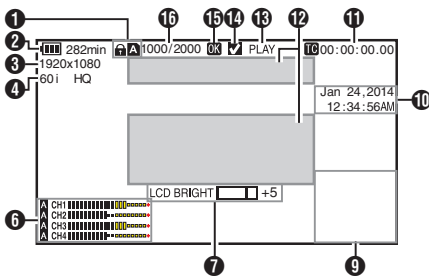

Media Display 2 Screen

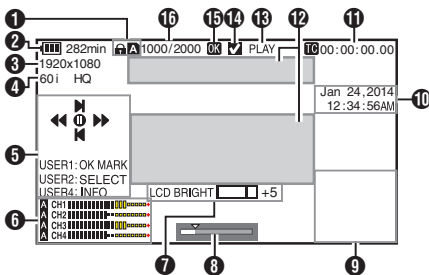

- 1 Media
 - Displays the media slot (A or B) of the currently played clip.
 - appears when the write-protect switch of the SD card is set.
 - 2 Voltage/Battery Power
 - Displays the current status of the power supply in use.
 - (P32 [Power Status Display])
- Memo : _____
- Displayed in the Media Display 0 screen during warnings only.
-
- 3 Resolution
 - Displays the video image resolution.
 - 4 Frame Rate/Bit Rate
 - Displays the frame rate and bit rate in pairs.
 - 5 Operation Guide
 - Displays a guide for the current operation buttons.
 - 6 Audio Level Meter
 - Displays the audio levels for [CH-1] to [CH-4].



- Memo : _____
- This item is not displayed when [Main Menu] → [LCD/VF] → [Display Settings] → [Audio Meter] is set to "Off".
 - (P123 [Audio Meter])

- 7 Volume Operation Indicator
 - This item is displayed when the LCD BRIGHT value (-10 to +10) is changed.
 - [LCD PEAKING +/-] operation is disabled in the Media mode, and its value is fixed at "-10".
 - (P147 [Volume Operation Indicator])
- 8 Position bar
 - Displays the current position in the video. During trimming, the position bar appears in green, and icons for the in and out points are displayed.
 - (P102 [Position bar])

- 9** Information Display
Use the [F.ASSIST/4] button to switch between camera information display, GPS display and turning off the display.
- The GPS display displays information on the recording location of the video being played back only when GPS information has been recorded. The local date/time is displayed.
 - Camera information display displays only information of Gain, Iris, Shutter and White Balance that have been recorded.

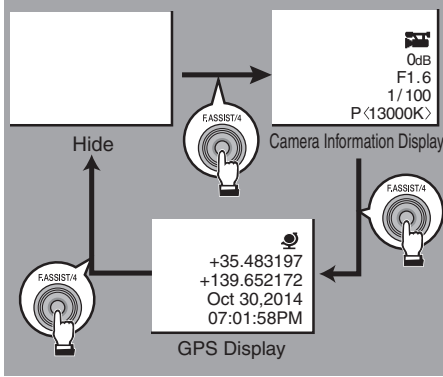

Memo : _____

- Trimming information is displayed while trimming is in progress. In this case, pressing the [F.ASSIST/4] button does not switch the display.

- 10** Date/Time Display
Displays the date/time that is recorded on the currently played SD card.

Memo : _____

- The date/time display style can be specified in [LCD/VF] → [Display Settings] → [Date Style]/[Time Style].
(☞ P124 [Date Style])
(☞ P124 [Time Style])

- 11** Time Code (TC)/User's Bit (UB) Display
- Displays the time code (hour: minute: second: frame) or user's bit data recorded in the SD card being played back.
 - Example of time code display:

TC00:00:00:00
※

* Colon (:) denotes non-drop frames and dot (.) denotes drop frames.

- Example of user's bit display:

UBFF EE DD 20

Memo : _____

- You can specify whether to display the time code, user's bit, or turn off the display in [TC/UB] of [Main Menu] → [LCD/VF] → [Display Settings].
(☞ P123 [TC/UB])

- 12** Event/Warning Display Area
Displays error messages.
(☞ P202 [Error Messages and Actions])

13 Media Status

- PLAY : Playing
STILL : Still picture playback mode
FWD * : High-speed playback in the forward direction (* playback speed: 5x, 15x, 60x, or 360x)
REV * : High-speed playback in the reverse direction (* reverse playback speed: 5x, 15x, 60x, or 360x)
STOP : Stop mode
P.OFF : Power OFF

- 14** Check Mark
Displayed when the currently played clip is selected.

- 15** OK Mark
Displayed when OK mark has been appended.
(☞ P99 [Appending/Deleting OK Mark])

- 16** Clip Information
Displays current clip number/total number of clips.

Status Screen

For checking the settings of the camera recorder.

Camera Screen

For checking information related to shooting using the camera recorder.

Camera	
Shooting Mode	Standard
FAW	None
GAIN L	0dB
GAIN M	6dB
GAIN H	12dB
AE LEVEL SW	AE Level

LCD/VF Screen

For checking information related to the LCD/VF screen settings.

LCD/VF	
Zebra 1	70%~80%
Zebra 2	70%~80%
Aspect Marker	16:9
Safety Zone	Off
Histogram	20%~80%

Record Format Screen

For checking information related to the recording format settings.

Record Format	
A Format	QuickTime(MPEG2) 1920x1080 60i(HQ) Audio 4ch
B Format	QuickTime(MPEG2) 1920x1080 60i(HQ) Audio 4ch

Audio Screen

For checking the settings related to audio input/output.

(P127 [Audio Set Item])

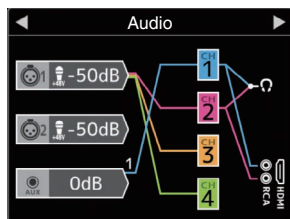

Audio Level Screen

For checking audio related information such as microphone volume level.

(P69 [Audio Recording])

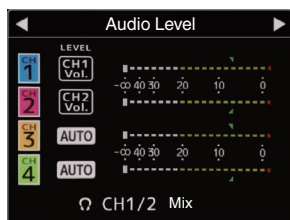

Planning Metadata Screen

For checking the current planning metadata setting.

(P132 [Record Format])

Planning Metadata	
Title1	
Title2	
Description	
Creator	

Network Screen

For checking the network-related settings.
( P139 [Wizard])

Network	
Type	P2P
SSID	HM890-
Security Type	WPA2
Passphrase	
IP Address	192.168.0.1
MAC Address	
Live Streaming	

USER Switch Set Screen

For checking the status (functions assigned) of the user buttons.

( P42 [Assignment of Functions to User Buttons])

USER Switch Set	
USER1	OIS
USER2	Marker
USER3	Load Picture File
USER4	Focus Assist
USER5	None
USER6	None
USER7	Zebra

Marker and Safety Zone Displays

The Grid Marker, Marker, Safety Zone, and Center Mark displays are useful in helping you determine the angle of view for the video image according to the shooting purpose.

The marker is displayed only in the Camera mode.

Displaying the Grid Marker

1 Set [LCD/VF] → [Marker Settings] → [Grid Marker] to “On”.

( P121 [Grid Marker])

A grid that divides the screen into 3x3 is displayed.



Memo : _____

- When [Grid Marker] is set to “On”, [Aspect Ratio], [Aspect Marker], and [Safety Zone] do not function.

Displaying the Aspect Ratio, Aspect Marker, Safety Zone, and Center Mark

1 Set [LCD/VF] → [Marker Settings] → [Grid Marker] to “Off”.

Perform setting for each of the [Aspect Ratio], [Aspect Marker], [Safety Zone], and [Center Mark] items.

- Example of display when [Aspect Ratio] = “4:3”, [Aspect Marker] = “Line+Halftone”, and [Center Mark] = “On”

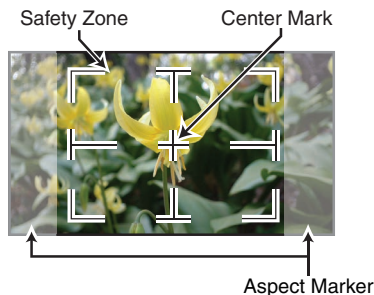

Memo : _____

- You can turn On/Off the safety zone and center mark displays using [LCD/VF] → [Marker Settings] → [Aspect Ratio], [Safety Zone], and [Center Mark].

(☞ P122 [Safety Zone])

Smoothing the Skin Color (Skin Detail Function)

The Skin Detail function can be used to reduce the contour enhancement of video signals for only the skin areas so as to produce a smoother skin tone.

1 Set [Skin Detail] to “On”.

(☞ P117 [Skin Detail])

Set [Main Menu] → [Camera Process] → [Detail]/[Adjust] → [Skin Detail] to “On”.

Memo : _____

- You can specify the adjustment level for the contour enhancement of the skin tone in [Main Menu] → [Camera Process] → [Detail]/[Adjust] → [Skin Detail]/[Level].

(☞ P117 [Level])

Color Bar Output

Color bars can be output on this camera recorder.

Memo : _____

- The audio test signals (1 kHz) can be output simultaneously with the color bar output.
(☞ P129 [Test Tone])

To Output the Color Bar Using the Menu

To output color bars, follow the setting procedure below.

1 Set [Camera Function] → [Bars] to “On”.

(☞ P108 [Bars])

Color bars are output.

To Output the Color Bar Using the User Button

1 Assign the “Bars” function to any of the user buttons.

(☞ P42 [Assignment of Functions to User Buttons])

2 Press the user button that is assigned with “Bars”.

Color bars are output.

Adjusting Color Matrix

- The color matrix of the camera recorder can be adjusted to a color of the user's preference.
- When shooting is performed using multiple cameras, the colors of the different cameras can be adjusted, and a color of the user's preference can be set on this camera recorder.
- The Saturation, Hue and Lightness of the primary and complementary colors (6 colors in total) can be set individually.
- Adjust the color on the vector scope and waveform monitor using the DSC color chart.
- * The adjusted values of "Standard", "Cinema Vivid", and "Cinema Subdued" in [Color Matrix] can be stored individually.
( P116 [Color Matrix])

1 Select [Camera Process] → [Color Matrix]/ [Adjust].

( P116 [Adjust])

2 Adjust Hue.

- Select the color using the cross-shaped button (▲▼) and confirm using the cross-shaped button (▶). (The cursor moves to Hue.)
- Pressing the cross-shaped button (▲) rotates the hue in the clockwise direction on the vector scope.
- Pressing the cross-shaped button (▼) rotates the hue in the anti-clockwise direction on the vector scope.

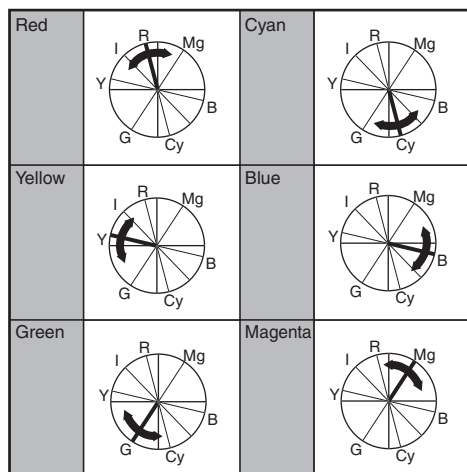

3 Adjust Saturation.

- Press the cross-shaped button (▶) to move the cursor to Saturation.
- Each of the colors changes in the direction indicated by the arrow on the vector scope.
- Pressing the cross-shaped button (▲) moves the color outward from the center of the circle on the vector scope.
- Pressing the cross-shaped button (▼) moves the color toward to the center of the circle on the vector scope.

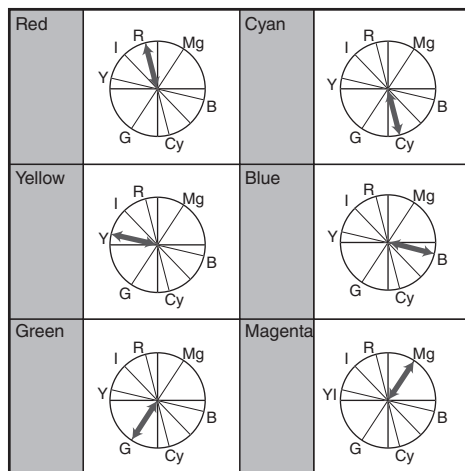

4 Adjust Lightness.

- Pressing the cross-shaped button (▲) lightens; and pressing the cross-shaped button (▼) darkens.
- Press the cross-shaped button (▶) to return the cursor to Hue.

Configuring Setup Files

The menu settings can be stored on the camera recorder or an SD card by saving them as a setup file.

Loading a saved setup file enables you to reproduce the appropriate setup state speedily. The following types of setup files are available.

■ Picture file:

File that contains image creation settings in accordance to the shooting conditions ([Camera Process] menu items).

■ All File:

File that contains all menu settings, ranging from video format settings to image creation settings such as device settings and shooting conditions, as well as the contents of the [Favorites Menu].

■ [User File]:

File that contains settings from All File that are not included in the [Camera Process] menu items.

(☞ P114 [Camera Process Menu])

Memo : _____

- Make use of the [Setup File] menu to save or load a setup file.
- The following operations can be performed on the [Setup File] menu.
 - [Saving Setup Files] (☞ P 157)
 - [Loading a Setup File] (☞ P 158)
 - [Deleting Setup Files] (☞ P 159)

Number of Storable Setup Files

Camera recorder : [CAM1] to [CAM4]

SD slot A : [A 1] to [A 8]

SD slot B : [B 1] to [B 8]

Compatibility

■ User File/All File

- Only User File/All File of the GY-HM890 and GY-HM850 series can be loaded.
- When User File/All File saved using GY-HM890 are loaded using GY-HM850, the functions that only exist on GY-HM890 are ignored.

■ Picture file

Only picture files of the GY-HM890 and GY-HM850 series can be loaded.

Saving Setup Files

1 Display the [Setup File] menu.

Select [Main Menu] → [System] → [Setup File] and press the Set button (●).
(☞ P130 [Setup File])

2 Select [Store File] and press the Set button (●).

3 Select [Picture File], [User File] or [All File], and press the Set button (●).

The existing files are displayed.

4 Select the file to be newly saved (or overwritten) using the cross-shaped button (▲▼), and press the Set button (●).

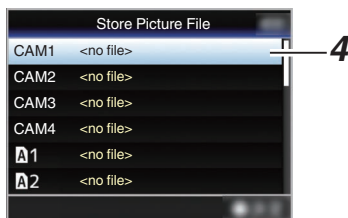

Memo : _____

- Files cannot be written in the following cases. (Displayed in gray, selection disabled)
 - When the inserted SD card is not supported or not formatted. (File name appears as “---”.)
 - When a write-protected SD card is inserted (a lock mark appears beside the SD card icon).

5 Name the file.

- Enter the surname using the software keyboard.
(☞ P105 [Text Input with Software Keyboard])
- You can enter up to 8 characters for the [Store File]/[Picture File] surname.

Memo : _____

- When overwriting an existing file, the surname of the existing file is displayed.
- Select [Cancel] and press the Set button (●), or press the [CANCEL] button to return to the previous screen.

6 Select [Store] and press the Set button (●).



7 Save the file.

- A confirmation screen appears when you choose to overwrite. Select [Overwrite] on the confirmation screen, and press the Set button (●). Saving starts, and “Storing...” appears on the screen.

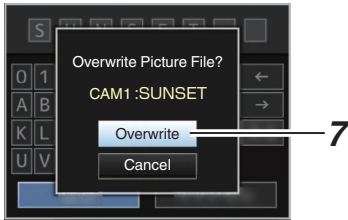

- Saving starts, and “Storing...” appears on the screen when the file is newly saved.



8 Saving is complete.

After saving of the file is complete, “Complete” appears on the screen, and the menu screen closes automatically.

Loading a Setup File

1 Display the [Setup File] menu.

Select [Main Menu] → [System] → [Setup File] and press the Set button (●). (☞ P130 [Setup File])

2 Select [Load File] and press the Set button (●).

3 Select [Picture File], [User File] or [All File], and press the Set button (●). The existing files are displayed.

4 Select the file to load using the cross-shaped button (▲▼), and press the Set button (●).

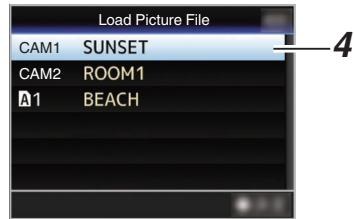

Memo :

- When the write-protect switch of the inserted SD card is set, a lock mark appears beside the SD card icon. Setup files can be loaded from an SD card even if the write-protect switch is set.
- Setup files that are completely incompatible will not be displayed. (☞ P157 [Configuring Setup Files])

5 Select [Load] on the confirmation screen, and press the Set button (●).

Loading starts, and “Loading...” appears on the screen.

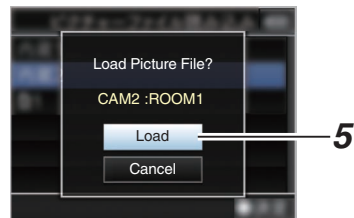

- 6 Reading is complete.**
After reading of the file is complete, “Complete” appears on the screen, and the menu screen closes automatically.

Deleting Setup Files

- 1 Display the [Setup File] menu.**
Select [Main Menu] → [System] → [Setup File] and press the Set button (●).
(P130 [Setup File])
- 2 Select [Delete File] and press the Set button (●).**
- 3 Select [Picture File], [User File] or [All File], and press the Set button (●).**
The existing files are displayed.
- 4 Select the file to delete using the cross-shaped button (▲▼), and press the Set button (●).**

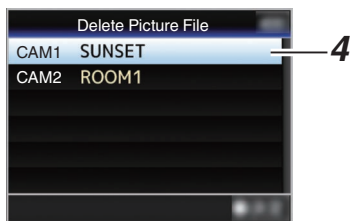

Memo : _____

- Scene files saved on the SD card cannot be deleted.
- _____

- 5 Select [Delete] on the confirmation screen, and press the Set button (●).**
Deletion starts, and “Deleting...” appears on the screen.

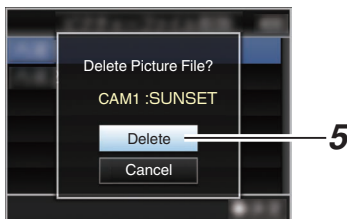

- 6 Deletion is complete.**
After file deletion is complete, “Complete” appears on the screen.

Managing/Editing Clips on a PC

Loading Clips to the PC (USB Connection Mode)

- You can load clips to a PC by connecting the camera recorder to the PC via the USB port. Doing so enables clips stored in the SD card to be managed and edited on the PC.
- Files on the SD card can be managed/edited on the connected PC in this mode only for USB mass storage class devices that are recognized by the said PC as a peripheral drive.

Memo : _____

- Files cannot be written to the SD card.
- Make sure to manage/edit files recorded in the MP4 file format using the (JVC ProHD Clip Manager) PC application software in the supplied disc.
- For details on how to install the application software, refer to the [User's Guide] of the [JVC ProHD Clip Manager] inside the supplied disc.

1 Connect the camera recorder to the PC using a USB cable.

A confirmation message "Change to USB Mode?" to enable the USB connection appears.

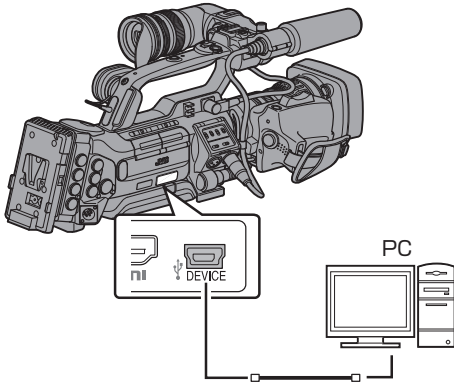

- 2 Select [Change] using the cross-shaped button (▲▼), and press the Set button (●). The camera recorder switches to USB mode.

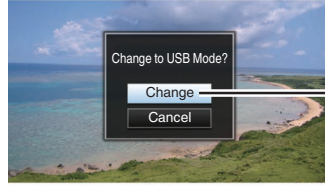

Memo : _____

- If recording is in progress, the "Change to USB Mode?" message appears after recording stops.
- If playback is in progress, the camera recorder switches to USB mode after the file closes automatically, such as when playback stops.

Disconnecting

- Disable the connection on the PC, then remove the USB cable from the camera recorder.
- Doing so exits the USB mode and switches the camera recorder to Camera mode.

Memo : _____

- The procedure for disabling the USB connection varies according to the PC in use. For details, refer to the "INSTRUCTIONS" of the PC.

When your PC cannot recognize the SD card

Confirm and update the OS of your PC.

OS	Description
Windows XP/ Windows XP SP1	Necessary to update to SP2 or higher.
Windows XP SP2/ Windows XP SP3	Necessary to download the update software. (KB955704) http://www.microsoft.com/downloads/details.aspx?familyid=1CBE3906-DDD1-4CA2-B727-C2DFF5E30F61&displaylang=en
Windows Vista	Necessary to update to SP1 or higher.
Windows Vista SP1/ Windows Vista SP2	Necessary to download the update software. (KB975823) <ul style="list-style-type: none"> • 32 bit version http://www.microsoft.com/downloads/en/details.aspx?FamilyID=2d1abe01-0942-4f8aabb2-2ad529de00a1 • 64 bit version http://www.microsoft.com/downloads/en/details.aspx?FamilyID=7d54c53f-017c-4ea5-ae08-34c3452ba315
Windows 7	Necessary to download the update software. (KB976422) <ul style="list-style-type: none"> • 32 bit version http://www.microsoft.com/downloads/en/details.aspx?FamilyID=3ee91fc2-a9bc-4ee1-aca3-2a9aff5915ea • 64 bit version http://www.microsoft.com/downloads/en/details.aspx?FamilyID=73f766dd-7127-4445-b860-47084587155f
Windows 8.1	Please check the website of Microsoft Corporation.

Connecting External Monitor

- To output live or playback video images and audio sound to an external monitor, select the output signals from the camera recorder, and connect using an appropriate cable according to the monitor to be used.
- Choose the most suitable terminal according to the monitor in use.
- [HD/SD SDI OUT] terminal:
Outputs either the HD-SDI signal or SD-SDI signal.
- [VIDEO OUT] terminal:
Outputs composite video signals.
- [HDMI] terminal:
Outputs HDMI signals.
Configure the settings in the [A/V Set] menu to match the monitor to be connected.
( P125 [HDMI/SDI Out])

Memo :

- When [Network] is set to “On(HDMI Off)” or “On(SDI Off)”, either HDMI signal or SDI signal is output.
( P131 [Network])

Connecting via SDI

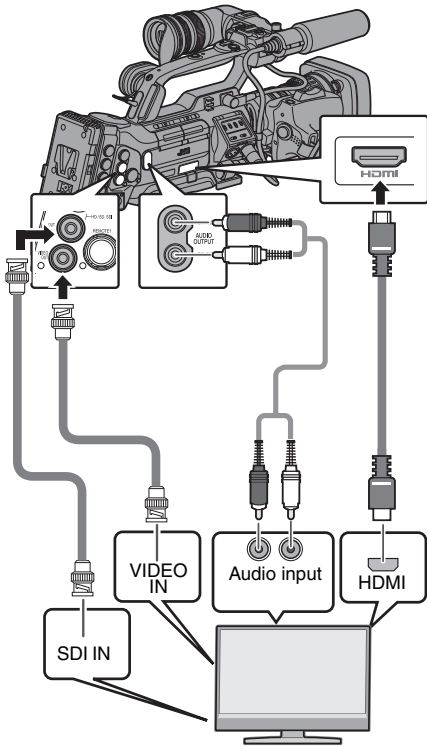

- Digital video signals, together with embedded (superimposed) audio signals and time code signals, are output for both the HD SDI and SD SDI signals.
- User's bit output from the [HD/SD SDI] output terminal is used as a flag to determine valid video signals. Therefore, accurate values will not be output.

Memo :

- The sampling frequency for embedded (superimposed) audio signals is 48 kHz. Time code of the built-in time generator as well as playback time code are also output.

Settings for SDI/Composite Down-Converted Output

- You can select the method to “down convert” HD video images to SD images during SD SDI or composite output.
- Set using [A/V Set] → [Video Set] → [SD Aspect].
- The available modes include “Side Cut”, “Letter” (blackened at the top and bottom), and “Squeeze” (full size, compressed at the left and right).
(☞ P125 [SD Aspect])

Memo :

- When [Record Format] → [System] is set to “SD”, and [SD Aspect] is set to “4:3”, this item cannot be selected.
(☞ P132 [System])
- When [Record Format] → [System] is set to “SD”, and [SD Aspect] is set to “16:9”, “Side Cut” in [A/V Set] → [Video Set] → [SD Aspect] cannot be selected.
(☞ P125 [SD Aspect])
(☞ P132 [System])

- * Select the output signal in [A/V Set] → [HDMI/SDI Out].
(☞ P125 [HDMI/SDI Out])
- * When [Record Format] → [System] is set to “SD”, only SD-SDI signals are output.
(☞ P132 [System])
- * To display the menu screen or display screen on the external monitor, set [A/V Set] → [Video Set] → [HDMI Out Character]/[SDI Out Character]/[VIDEO Out Character] to “On”.
(☞ P126 [HDMI Out Character])
(☞ P126 [SDI Out Character])
(☞ P126 [VIDEO Out Character])

Connecting a Earphone

- Audio output from the [PHONES] terminal can be selected using the [A/V Set] → [Monitor] item or the [MONITOR] selection switch on the camera recorder.
(P129 [Monitor])
- The different combinations of settings that are output from the [PHONES] terminal and monitor speaker are as follows.

[MONITOR] Selection Switch Setting	[Monitor] Setting	[PHONES] Terminal		Speaker
		L	R	
[CH-1]	-	CH-1		CH-1
[BOTH]	[Mix]	CH-1+CH-2		CH-1+CH-2
	[Stereo]	CH-1	CH-2	
[CH-2]	-	CH-2		CH-2

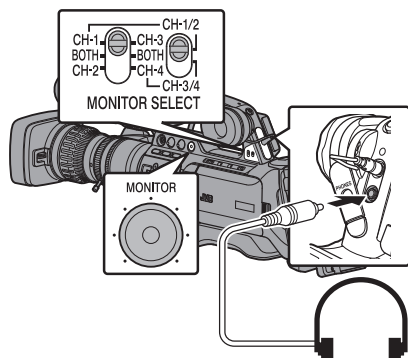

- 1 Connect a earphone.
- 2 Select the channels to monitor using the different combinations of the left and right [MONITOR SELECT] switches.

[MONITOR SELECT] Setting	Channels to Monitor	Description
	[CH-1]	Outputs the audio recorded in [CH-1].
	[CH-2]	Outputs the audio recorded in [CH-2].
	[CH-1]/[CH-2]	Outputs the audio recorded in [CH-1] and [CH-2].
	[CH-3]	Outputs the audio recorded in [CH-3].
	[CH-4]	Outputs the audio recorded in [CH-4].
	[CH-3]/[CH-4]	Outputs the audio recorded in [CH-3] and [CH-4].

- 3 Use the [MONITOR] adjustment knob to adjust the monitor volume.

Connecting Wired Remote Control

You can operate the functions of this unit with a wired remote control.

Memo : _____

- When the switches of the camera recorder and remote control unit are operated at the same time, the switch operation of the remote control unit takes priority over that of the camera recorder.

1 Connect a wired remote control to the camera recorder.

Connect the wired remote control (sold separately) to the [REMOTE2] terminal of this camera recorder.

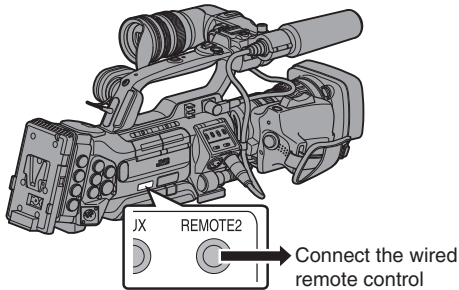

Caution : _____

- Turn off the power of the camera recorder when connecting a wired remote control.

2 Turn on the power of the camera recorder.

Connecting a Remote Control Unit

The switch functions of the camera recorder can be configured using the remote control unit.

- * Remote control units supported: RM-LP25U, RM-LP55U, RM-LP20G

1 Connect the remote control unit to the camera recorder.

Connect the remote cable of the remote control unit to the [REMOTE1] terminal located at the terminal section of this camera recorder.

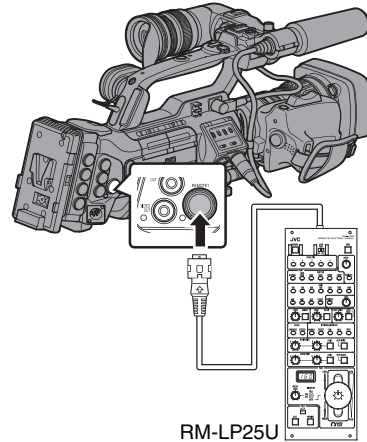

Caution : _____

- Turn off the power of the camera recorder when connecting a remote control unit.

2 Turn on the power of the camera recorder.

3 Set the operate switch of the remote control unit to ON.

Memo : _____

- For details on the functions operable from the remote control unit, please refer to [Functions Operable from the Remote Control Unit] (P 166).

Precautions on Using the Remote Control Unit

- When the switches of the camera recorder and remote control unit are operated at the same time, the switch operation of the remote control unit takes priority over that of the camera recorder.
- Focus and zoom operations cannot be performed using the remote control unit.
- The shutter speed may vary slightly from the value displayed on the camera recorder.
- When the frame rate of the [A]Frame & Bit Rate/[B]Frame & Bit Rate items on the camera recorder is set to “24p”, shutter speed cannot be set to “1/60” from the remote control unit. The shutter speed of “1/48” will be used even when “1/60” is selected.
(☞ P133 [A Frame & Bit Rate])
(☞ P134 [B Frame & Bit Rate])
- While the camera recorder is in the Media mode, the Auto White Balance feature does not function even if you operate it from the remote control unit.
- When the H phase is set using a remote control unit, only the H phase of the SD signal is activated.
- When setting the H Phase using a remote control unit, any value beyond the setting range in the menu of the camera recorder cannot be set.
(☞ P126 [HD-SDI H Phase])

Functions Operable from the Remote Control Unit

RM-LP25U

Function		✓: Available -: Not available
SHUTTER	NORMAL	✓
	1/100*1, 1/120*2	✓
	1/250	✓
	1/500	✓
	1/1000	✓
	1/2000	✓
	VARIABLE	✓
	- SPEED	
GAIN	-6dB	✓
	-3dB	✓
	0dB	✓
	3dB	✓
	6dB	✓
	9dB	✓
	12dB	✓
	15dB	✓
	18dB	✓
	ALC	✓
	LOLUX	✓
	VARIABLE	-
	- LEVEL	
	DETAIL	
- LEVEL		✓
GAMMA		✓
	- LEVEL	✓
BLACK	STRETCH*3	✓
	NORMAL	✓
	COMPRESS*3	✓
WHITE BALANCE MODE	MANUAL	✓
	PRESET	✓
	FAW	✓
	AW A	✓
	AW B	✓
WHITE PAINT		✓
AUTO WHITE		✓
AUTO BLACK		-

Function		✓: Available -: Not available
BLACK PAINT		✓
IRIS CONTROL		✓
	- Iris F Value Display	✓
MASTER BLACK		✓
TALLY (LED)		✓
CALL*4		✓
PREVIEW		-
AUTO KNEE		✓
KNEE POINT		✓
BARS		✓
TALLY (PGM)*4	Rear Input	✓
TALLY (PVW)*4	Rear Input	✓

RM-LP55U

Function		✓: Available -: Not available	
CAM MODE	CAM, BARS	✓	
CONTOUR	OFF, ON (LEVEL)	✓	
GAMMA	OFF, ON (LEVEL)	✓	
WHT.BAL.	MANUAL, PRESET, AUTO1, AUTO2, FAW	✓	
	AUTO WHITE	✓	
	WHITE PAINT	✓	
GAIN	dB mode 0dB, +3dB, +6dB, +9dB, +12dB, +15dB, +18dB	✓	
	ALC+EEI	✓	
	ALC	✓	
PAINT	R	✓	
	B	✓	
SHUTTER	NORMAL	✓	
	STEP	1/100*1, 1/120*2, 1/250, 1/500, 1/1000, 1/2000, 1/4000, 1/10000	✓
		EEI	✓

Function		✓: Available -: Not available
IRIS	MANUAL, AUTO	✓
	AUTO IRIS LEVEL, MANUAL IRIS LEVEL	✓
ZOOM	WIDE, STOP, TELE	✓ LENS
FOCUS	NEAR, STOP, FAR	✓ LENS
H.PHASE		✓

RM-LP20G

Function		✓: Available -: Not available
MODE (BARS)		✓
SHUTTER	NORMAL	✓
	1/100*1, 1/120*2	✓
	1/250	✓
	1/500	✓
	1/1000	✓
	1/2000	✓
	EEI	✓
GAIN	0	✓
	3dB	✓
	6dB	✓
	9dB	✓
	12dB	✓
	18dB	✓
	ALC	✓
DETAIL	- LEVEL	✓
	- LEVEL	✓
GAMMA	- LEVEL	✓
	- LEVEL	✓
AUTO KNEE	- KNEE POINT	✓
	- KNEE POINT	✓
WHITE BALANCE MODE	MANUAL	✓
	PRESET	✓
	FAW	✓
	AW A	✓
	AW B	✓
PAINT		✓
WHITE PAINT	R(LEVEL)	✓
	B(LEVEL)	✓
AUTO WHITE		-
MASTER BLACK		✓
IRIS	AUTO/MANUAL	✓
	- LEVEL	✓

Function		✓: Available -: Not available
TALLY (LED)	(RED: PGM)	✓
	(GREEN: PVM)	✓
PREVIEW		-
CALL*4		✓
TALLY(PGM)*4	Rear Input	✓
TALLY(PVW)*4	Rear Input	✓

RM-HP790DU/RM-HP790DE

Function		✓: Available -: Not available
MODE (BARS)		✓
DETAIL (CONTOUR)	- LEVEL	✓
	- LEVEL	✓
DETAIL BAL	H/V	✓
DTL FRQ	LOW, MIDDLE, HIGH	✓
	AUTO	-
SKIN DTL		✓
FULL AUTO SHOOTING		✓
IRIS	- MANUAL LEVEL	✓
	- AUTO IRIS LEVEL	✓
	- AUTO IRIS LEVEL	✓
WHITE BALANCE	MANUAL	✓
	PRESET	✓
	AUTO1	✓
	AUTO2	✓
FAW		✓
PAINT	R, B	✓
AUTO	SET	-
	WHITE	✓
GAIN	0dB, +3dB, +6dB, +9dB, +12dB, +15dB, +18dB, ALC+EEI, ALC	✓
	+24dB, -3dB, VARIABLE GAIN	✓
	LOLUX	✓

Function		✓: Available -: Not available
SHUTTER	OFF, 1/100*1, 1/120*2, 1/250, 1/500, 1/1000, 1/2000, 1/4000, 1/10000 V.SCAN	✓
BLACK	NORMAL, STRETCH, COMPRESS	✓
V.RESOLUTION (HI-RESO)		-
AUTO KNEE		✓
-	KNEE POINT	✓
GAMMA		✓
-	LEVEL	✓
DNR		✓
-	LEVEL	-
COLOR MATRIX		-
SMOOTH TRANS		✓
MASTER BLACK		✓
ASPECT RATIO	4:3, 16:9, LETTER	-
H.PHASE		✓
HD H.PHASE		✓
SC COARSE	0°, 90°, 180°, 270°	-
CALL*4		✓
TALLY(PROGRAM)*4		✓
TALLY(PREVIEW)*4		✓

*1 Only when the frame rate of the [A]Frame & Bit Rate] and [B]Frame & Bit Rate] items in the [Record Format] menu of the camera recorder is set to “60”, “30”, or “24”.

*2 Only when the frame rate of the [A]Frame & Bit Rate] and [B]Frame & Bit Rate] items in the [Record Format] menu of the camera recorder is set to “50” or “25”.

*3 “Normal” when both [Stretch] and [Compress] are set to “Off”.

*4 Available only when [System] → [Tally System] is set to “Studio” during startup.

Inputting SDI Signals from an External Device **890**

890CH

The camera recorder comes equipped with a [SDI IN] terminal on the side, which enables HD/SD SDI signals from an external device to be recorded to the SD card.

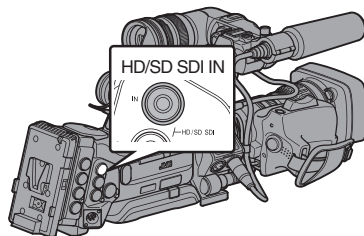

1 Set the camera recorder to the Camera mode.

(☞ P18 [Operation Modes])

2 Set [System] to “HD(SDI In)” or “SD(SDI In)”.

Set [Main Menu] → [System] → [Record Set] → [Record Format] → [System] to “HD(SDI In)” or “SD(SDI In)”.

3 Input SDI signals from the external device to the [SDI IN] terminal.

4 Set the [Record Format] item.

Set each item according to the selected [System] item.

(☞ P132 [Record Format])

SDI Input Signal	A Resolution
1080/59.94i	1920×1080
1080/50i	1440×1080
720/59.94p	1280×720
720/50p	
480/59.94i	720×480 (U model)
576/50i	720×576 (E model)

Memo :

- When a signal with a recording format other than those stated in the table is input, “Invalid Sync” will be displayed.

5 Start and stop recording on the camera recorder.

- The input signals are output in the HD-SDI/SD-SDI format from the video output terminals.
- “SDI IN ” appears on the display screen.

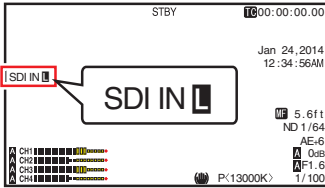

Memo : _____

- Checking of the recording (clip review) is disabled while you are recording external video signals.
- Do not disconnect the cables connecting to the input terminal while recording is in progress.
- The “” mark blinks when the format of the input signal is different from the format selected in step 4, or when there is no signal input.

Inputting External Synchronizing Signals (Genlock)

- A [GENLOCK] terminal is available on the side of the camera recorder.
- You can input synchronizing signals from a KA-M790G unit (Multicore Remote Adapter: sold separately) that is connected to the accessory connection terminal (68 pins) on the rear of the camera recorder. **890 890CH**
- SDI signals (digital signals) can be input from the [HD/SD SDI IN] terminal on the side. **890 890CH**
- Input external synchronizing signals from the [GENLOCK] terminal and [HD/SD SDI IN] terminal (**890 890CH**), and synchronize the camera video with the external signal.
- The H (Horizontal) Phase of the camera recorder's video signals can be adjusted with respect to the external synchronizing signals on the [A/V Set] → [Video Set] → [Genlock Adjust] screen.
( P126 [Genlock Adjust])

Memo : _____

- The genlock feature is only usable in the Camera mode.

Genlock Signal Settings

For analog signal input

■ Synchronizing signal used

- SD synchronizing : BB (Black Burst) signal
Supports SMPTE170M (RS-170A)-NTSC
Supports ITU-R BT.470-6 PAL
- HD synchronizing : HDTV tri-level synchronizing signal
Supports SMPTE296M-HD720p
Supports SMPTE274M-HD1080i

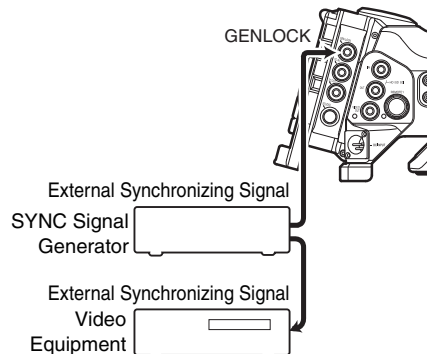

- 1 **Set the camera recorder to the Camera mode.**
(☞ P18 [Operation Modes])
- 2 **Set [Genlock Input] to “BNC”.** 890 890CH
Set [A/V Set] → [Video Set] → [Genlock Input] to “BNC”.
(☞ P126 [Genlock Input 890 890CH])

Memo : _____

- Set to “Adapter” to input synchronizing signal from the accessory connection terminal (68 pins) on the rear of this unit.

3 When in the standby or stop mode, input synchronizing signals from the SYNC signal generator to the [GENLOCK] terminal.

- When the camera recorder’s video is locking to the external synchronizing signal, “Sync Locking” appears on the screen.
- After locking to the external synchronizing signal is complete, the display disappears and recording can be performed.
- If there is genlock signal input but the signal format is not supported, “Invalid Sync” is displayed.

Memo : _____

- If the frame rate of [A]Frame & Bit Rate/[B]Frame & Bit Rate in the [Record Format] menu is set to “60p”, “60i”, “30p”, or “24p”, 59.94 Hz synchronizing signals (vertical synchronization) are input.
50 Hz/60 Hz synchronizing signals are not synchronized.
- If the frame rate of [A]Frame & Bit Rate/[B]Frame & Bit Rate in the [Record Format] menu is set to “50p”, “50i”, or “25p”, 50 Hz synchronizing signals (vertical synchronization) are input.
59.94 Hz/60 Hz synchronizing signals are not synchronized.
(☞ P133 [A Frame & Bit Rate])
(☞ P134 [B Frame & Bit Rate])
- Do not connect or disconnect the input cable for the synchronizing signals during recording or playback
- If the power is turned on during input of external synchronizing signals, vertical oscillation may occur. This is not a malfunction.
- Signals such as VTR playback signals with jitters may not be synchronized on this camera recorder.

- Only H (Horizontal) and V (Vertical) genlock functions are available on this camera recorder. It does not come with a lock function for SC (sub-carrier). Color flash may occur during switching such as when composite signals are used by a switcher.

■ Phase Items to Synchronize

The phase items to be synchronized may vary depending on the input synchronizing signal and output video signal.

Output Video Signal		Input Synchronizing Signal		
		BB	Tri-sync	
			720p	1080i
VIDEO	Composite	H, V, F	V	V, F
Y/PB/PR 890 890CH	SD Component	H, V, F	V	V, F
	HD Component 720p	V	H, V	V
	HD Component 1080i	V, F	V	H, V, F
HD/SD SDI	SD-SDI	H, V, F	V	V, F
	HD-SDI 720p	V	H, V	V
	HD-SDI 1080i	V, F	V	H, V, F

H : Horizontal Phase
V : Vertical Phase
F : Field Phase

For digital signals (SDI) input 890 890CH

Input external synchronizing signals from the [HD/SD SDI IN] terminal, and synchronize the camera video with the external signal.

■ Synchronizing signal used

SD synchronizing : Supports SMPTE259M signal

HD synchronizing : Supports SMPTE292M signal

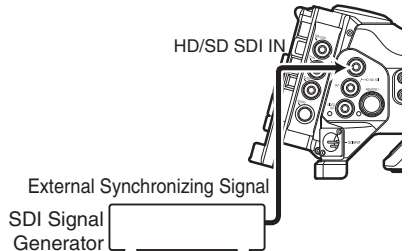

1 Set the camera recorder to the Camera mode.

(☞ P18 [Operation Modes])

2 Set [Genlock Input] to “SDI”.

Set [A/V Set] → [Video Set] → [Genlock Input] to “SDI”.

(☞ P126 [Genlock Input **890 890CH**])

Memo : _____

- Set to “Adapter” to input synchronizing signal from the accessory connection terminal (68 pins) on the rear of this unit.

3 When in the standby or stop mode, input synchronizing signals from the SDI signal generator to the [HD/SD SDI IN] terminal.

- When the camera recorder’s video is locking to the external synchronizing signal, “Sync Locking” appears on the screen.
- After locking to the external synchronizing signal is complete, the display disappears and recording can be performed.
- If there is genlock signal input but the signal format is not supported, “Invalid Sync” is displayed.

Memo : _____

- If the frame rate of [A]Frame & Bit Rate/[B]Frame & Bit Rate] in the [Record Format] menu is set to “60p”, “60i”, “30p”, or “24p”, 59.94 Hz synchronizing signals (vertical synchronization) are input. 50 Hz/60 Hz synchronizing signals are not synchronized.
- If the frame rate of [A]Frame & Bit Rate/[B]Frame & Bit Rate] in the [Record Format] menu is set to “50p”, “50i”, or “25p”, 50 Hz synchronizing signals (vertical synchronization) are input. 59.94 Hz/60 Hz synchronizing signals are not synchronized.
(☞ P133 [A Frame & Bit Rate])
(☞ P134 [B Frame & Bit Rate])
- Do not connect or disconnect the input cable for the synchronizing signals during recording or playback
- If the power is turned on during input of external synchronizing signals, vertical oscillation may occur. This is not a malfunction.
- Signals such as VTR playback signals with jitters may not be synchronized on this camera recorder.
- Only H (Horizontal) and V (Vertical) genlock functions are available on this camera recorder. It does not come with a lock function for SC (sub-carrier). Color flash may occur during switching such as when composite signals are used by a switcher.

■ Phase Items to Synchronize

The phase items to be synchronized may vary depending on the input synchronizing signal and output video signal.

Output Video Signal		Input Synchronizing Signal		
		SD-SDI	HD-SDI	
			720p	1080i
VIDEO	Composite	H, V, F	V	V, F
Y/PB/PR 890 890CH	SD	H, V, F	V	V, F
	Component			
	HD Component 720p	V	H, V	V
	HD Component 1080i	V, F	V	H, V, F
HD/SD SDI	SD-SDI	H, V, F	V	V, F
	HD-SDI 720p	V	H, V	V
	HD-SDI 1080i	V, F	V	H, V, F

| Adjusting H Phase

1 Select [Genlock Adjust] in the [A/V Set] menu.

Adjust the [A/V Set] → [Video Set] → Genlock Adjust item as follows.

(☞ P126 [Genlock Adjust])

[Analog SD H Phase] : Adjusts the H Phase of the SD analog signal.

[Analog HD H Phase] : Adjusts the H Phase of the HD analog signal.
890 890CH

[SD-SDI H Phase] : Adjusts the H Phase of the SD SDI signal.

[HD-SDI H Phase] : Adjusts the H Phase of the HD SDI signal.

2 Select a value using the cross-shaped buttons (▲▼).

- The H Phase of the camera recorder’s video signal is adjusted with respect to the external synchronizing signal input from the [GENLOCK] terminal.
- The setting value of the [Analog HD H Phase] **890 890CH**, [SD-SDI H Phase], and [HD-SDI H Phase] items can be adjusted in increments of 10 by pressing the cross-shaped button (▲▼) for 2 seconds or longer.

Memo : _____

- Adjustment cannot be made while recording or playback is in progress.
- The video image may be disrupted momentarily during adjustment. This is not a malfunction.

Displaying Return Videos from an External Device

890 890CH

Return video from an external device (switcher, etc.) can be displayed on the viewfinder or LCD monitor of the camera recorder.

(☞ P127 [Return Input **890 890CH**])

Memo : _____

- This feature is only usable in the Camera mode.

1 Set the camera recorder to the Camera mode.

(☞ P18 [Operation Modes])

2 Assign the “Return Video” function to any of the user buttons.

(☞ P42 [Assignment of Functions to User Buttons])

* This excludes the [AUTO FOCUS/11] button.

3 Select the way the return video is to be displayed.

Set using [Main Menu] → [Camera Function] → [User Switch Set] → [Return Video].

(☞ P113 [Return Video])

4 Select the input destination of the return video.

The input destination of the return video can be set using the [A/V Set] → [Video Set] → [Return Input] item.

(☞ P127 [Return Input **890 890CH**])

5 Select the aspect ratio of the return video.

Set using [A/V Set] → [Video Set] → [Return Aspect].

(☞ P127 [Return Aspect **890 890CH**])

6 Press the user button that is assigned with the “Return Video” function.

- By pressing the user button assigned with the “Return Video” function, the captured image or return video is displayed according to the method specified in step 3.

Memo : _____

- When the return video is displayed in full screen, the following displays and operations are disabled.
 - Zebra display
 - Skin Detail operation
 - Spot Meter display
 - Focus Assist feature (ACCU-Focus operation)
 - Aspect Marker display
 - Safety Zone display
 - Center Mark display
- During display of PiP and return video in full screen, the [LCD Mirror] setting becomes invalid and is set automatically to “Normal”.
(☞ P120 [LCD Mirror])

Studio System **890 890CH**

[Details of the Studio Terminal

Connect to the [STUDIO] terminal (10-pin) when you are combining the use of devices such as a transmission unit manufactured by a different company.

PIN No.	Signal Name	Input/Output
1	NC	-
2	CALL TALLY	IN
3	RM TALLY	OUT
4	RM PREVIEW	OUT
5	NC	-
6	NC	-
7	TALLY IN	IN
8	RETURN GND	-
9	RETURN IN	IN
10	GND	-

Studio System Connection Example

Memo : _____

- For details on the connection with a remote control unit, please refer to the instruction manual for the remote control unit.
- VF-HP840U does not function even when it is connected to this camera recorder.

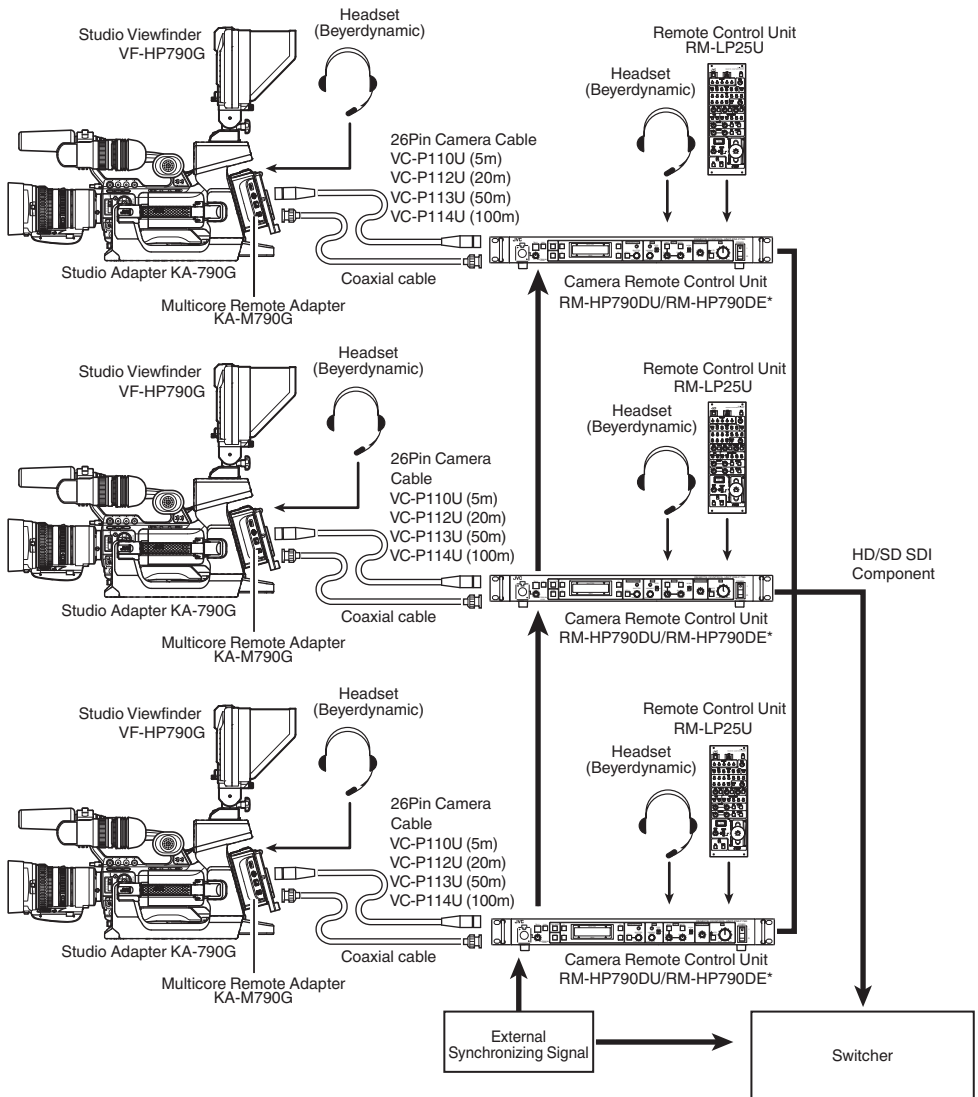

Connecting External Devices

* Models with an E suffix are for the European market and the UL Listing mark is not applicable.

Functions of Network Connection

- The network function can be operated by connecting one of the following adapters to the rear [HOST] terminal.
 - Wireless LAN adapter
 - Ethernet adapter
 - Cellular adapter(☞ P175 [Camera Setup for Network Connection])
- The network feature comprises web-browser-based functions using devices such as a smartphone, tablet terminal, or PC, as well as FTP and live streaming functions that run via thumbnail screens and menu operation.

| List of Functions

Importing Metadata

You can download a metadata settings file (XML format) from the FTP server and store metadata in the camera recorder.

(☞ P178 [Importing Metadata])

Uploading Recorded Clips

You can upload clips recorded in the SD card to a preset FTP server.

(☞ P180 [Uploading a Recorded Video Clip])

Memo : _____

- Uploading can also be performed via a web browser.
(☞ P187 [Uploading a Recording Clip via a Web Browser])

Editing Metadata

- Planning Metadata
You can access the page for editing the camera recorder's metadata via a web browser on devices such as a smartphone, tablet terminal, or PC, and edit the metadata that is to be applied to clips to be recorded.

(☞ P183 [Planning Metadata])

- Clip Metadata
You can access the page for editing the metadata via a web browser on devices such as a smartphone, tablet terminal, or PC, and display or rewrite the metadata that is recorded to a clip.

(☞ P184 [Clip Metadata])

View Remote

You can access via a web browser on devices such as a smartphone, tablet terminal, or PC to check the live image and perform remote control operations of the camera.

(☞ P190 [View Remote Feature])

Camera Control

You can access via a web browser on devices such as a smartphone, tablet terminal, or PC to remotely control the camera.

(☞ P193 [Camera Control Function])

Live streaming

By combining with a decoder device or PC application that support live streaming, you can perform audio and video streaming via the network.

(☞ P199 [Performing Live Streaming])

Preparing Network Connection

| Operating Environment

Computer

■ CPU

Core 2 Duo 2.4 GHz or higher

■ Memory

2 GB or higher

■ Display

1024x768 or higher

■ OS

- Windows XP SP3/Windows Vista SP2 (32bit/64bit)/Windows7 SP1 (32bit/64bit)/Windows 8.1 (32bit/64bit)

- Mac OS X v10.5 or later

■ Web Browser

- Internet Explorer 8 or later
- Safari 6 or later
- Google Chrome 31 or later
- Mozilla Firefox 25 or later

Smartphone/Tablet Terminal

■ iPhone/iPad/iPod touch

iOS 6 or later, screen resolution of 960 x 640 dots or higher (Safari 6 or later)

■ Android Smartphone/Tablet

Android 4.0 or later, screen resolution of 1280 x 800 dots or higher (standard browser or Chrome)

Camera Setup for Network Connection

1 Connect an appropriate adapter according to the intended use to the [HOST] terminal at the rear of the camera recorder.

The following adapters can be connected.

- Wireless LAN adapter
- Ethernet adapter
- Cellular adapter

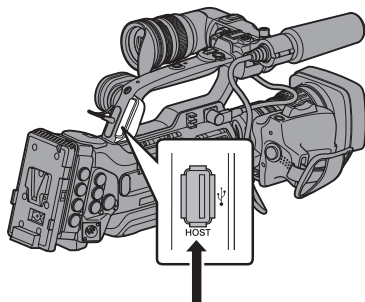

Connect an appropriate adapter

Memo : _____

- Only a network connection adapter can be connected to the [HOST] terminal.
- Connect or disconnect an adapter only after you have turned off the power of the camera recorder.
- You can find the latest information on the compatible adapters at the product page of our website.
- Two types of network coverage (WAN and LAN) are available for each application.

2 Enable the network connection.

Set [Main Menu] → [System] → [Network] to “On(HDMI Off)” or “On(SDI Off)”.

3 Configure the connection settings.

- Select [Main Menu] → [System] → [Network]/[Settings] → [Connection Setup] → [Wizard] and press the Set button (●).
- A wizard screen appears according to the type of adapter connected. Follow the instructions on the screen to perform setting.
(☞ P175 [Connecting via Wireless LAN])
(☞ P177 [Connecting via Wired LAN])
(☞ P177 [Connecting via Cellular Adapter])

Connecting via Wireless LAN

Connection via Access Point

1 Perform setting on the camera recorder, and start up the [Wizard] screen.

(☞ P175 [Camera Setup for Network Connection])

2 [Wireless LAN] appears on the [Wizard] screen.

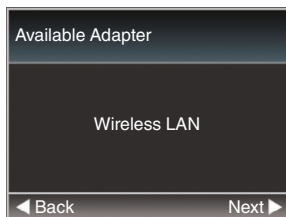

3 Press the ► button to display the [Select Connection Type] screen.

Select “Connect with Access Point”.

Follow the screen instructions to complete setting. Perform setting for the following.

- Mode of connection
- Method of setting
* SSID, type of encryption, Passphrase, and IP Address setting (“DHCP” or “Manual”) in cases other than WPS

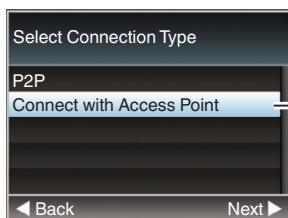

4 Setting is complete.

After setting is complete, you can access the camera recorder via a web browser.

(☞ P182 [Connecting from a Web Browser])

P2P Connection

You can access the web function of this camera recorder from devices such as a smartphone, tablet terminal, or PC.

1 [Wireless LAN] appears on the [Wizard] screen.



2 Press the ► button to display the [Select Connection Type] screen.

Select "P2P".

Follow the screen instructions to complete setting.

Perform setting for the following.

- Mode of connection
- Method of setting
 - * SSID and Passphrase in cases other than WPS

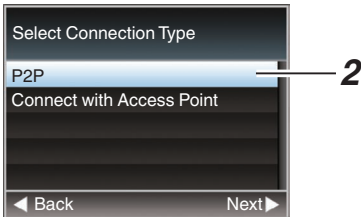

Memo :

- When "WPS" is selected in the [Select Setup Type] screen, the following steps 3 and 4 are not required.

3 Set the camera recorder to the Camera mode, and display the [Network] (status) screen.

- Press the [STATUS] button on the camera recorder to display the status screen. Press the cross-shaped button (◀▶) to display the [Network] screen.
- Check to ensure that the SSID and Passphrase that you have set in the wizard are displayed.

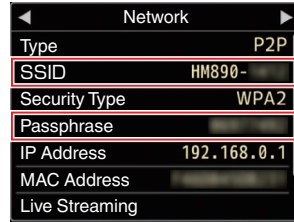

4 Select SSID from the list of access points (smartphone, tablet terminal, PC, etc.), and enter Passphrase.

- Display a list of the access points in the wireless connection settings of the smartphone, tablet terminal or PC, and select "HM890--*****" or "HM850--*****". (***** are numbers that vary with the device used.)
- After the password confirmation screen appears, enter the [Passphrase] displayed on the [Network] screen.

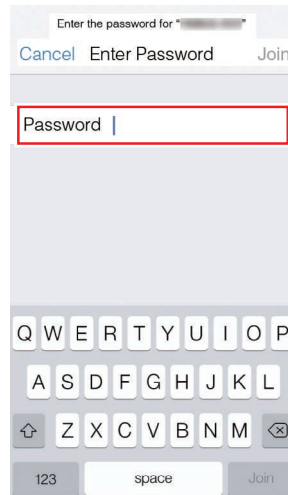

5 Setting is complete.

After setting is complete, you can access the camera recorder via a web browser.

(☞ P182 [Connecting from a Web Browser])

Connecting via Wired LAN

You can connect a device such as a smartphone, tablet terminal, or PC to the camera recorder using an Ethernet hub to access the camera recorder's web functions. Alternatively, you can also connect directly using a cross cable.

- 1 **Attach the Ethernet adapter to the [HOST] terminal on the camera recorder, then connect to the smartphone, tablet terminal, or PC with an Ethernet hub or a cross cable.**
- 2 **Perform setting on the camera recorder, and start up the [Wizard] screen.**
(☞ P175 [Camera Setup for Network Connection])
- 3 **[Ethernet] appears on the [Wizard] screen.**

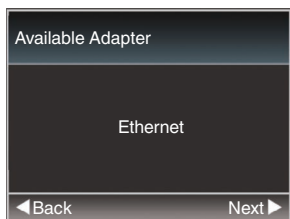

- 4 **Press the ► button to display the [IP Address Configuration] screen.**

Follow the screen instructions to complete setting. Perform setting for the following.

- IP address setting method (DHCP or manual)
- IP Address
- Subnet Mask
- Gateway
- DNS Server

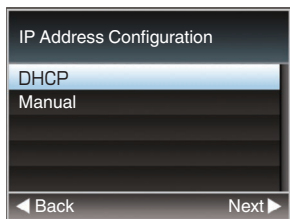

- 5 **Setting is complete.**

After setting is complete, you can access the camera recorder via a web browser.

(☞ P182 [Connecting from a Web Browser])

Connecting via Cellular Adapter

You can make use of the FTP function and live streaming function by connecting a cellular adapter to this camera recorder.

- 1 **Connect the cellular adapter to the [HOST] terminal of the camera recorder.**
- 2 **Perform setting on the camera recorder, and start up the [Wizard] screen.**
(☞ P175 [Camera Setup for Network Connection])
- 3 **[Cellular] appears on the [Wizard] screen.**

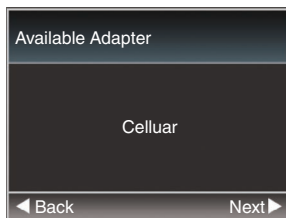

- 4 **Press the ► button.**

Follow the screen instructions to complete setting. Perform setting for the following.

- Connection phone number
- User name
- Password

Caution :

- You can access the web functions via a web browser on devices such as a smartphone, tablet terminal, or PC only in a LAN environment.
- Note that you may have to pay very high bills in the case of pay-per-use contracts. Fixed price contract is recommended if you are using the network function.
- Note that the use of improper settings may result in expensive bills from the phone service provider. Make sure that the setting is correct.
- To avoid expensive bills due to the roaming connection, you are recommended to use this function by disabling the roaming contract.
- There may be communication even when you are not using the network function. Remove the cellular adapter when the function is not in use.

Importing Metadata

You can download a metadata settings file (XML format) from the FTP server and store metadata in the camera recorder. The imported metadata is applied to clips to be recorded.

Preparing Metadata

- You can record the four metadata types below.
 - Title1 : ASCII only, max. 63 characters (bytes)
 - Title2 : UNICODE, max. 127 bytes
 - Creator : UNICODE, max. 127 bytes
 - Description : UNICODE, max. 2047 bytes
- Metadata makes use of the XML description format.
- Edit the <Title1>, <Title2>, <Description>, <Creator> tag element using the XML editor. (Indicated by the frames below)

```
<?xml version="1.0" encoding="UTF-8"?>
<NRT-MetalInterface lastUpdate="2014-01-26T18:06:21+09:00"
xmlns="urn:schemas-proHD:nonRealTimeMetalInterface:ver.1.00"
xmlns:xsi="http://www.w3.org/2001/XMLSchema-instance">
  <MetaData>
    <Title1>Title1 sample</Title1>
    <!-- only "en",max63bytes -->
    <Title2>Title2 sample</Title2>
    <!-- ,max127bytes -->
    <Description>Description sample</Description>
    <!-- ,max2047bytes -->
    <Creator>Creator sample</Creator>
    <!-- ,max127bytes -->
  </MetaData>
</NRT-MetalInterface>
```

Configuring the Server for Downloading

For specifying the settings (server name, user name, password, etc.) for connecting to the FTP server for downloading the metadata as well as the path of the file to download.

1 Open the [Metadata Server] screen.

Open the [Main Menu] → [System] → [Network]/[Settings] → [Metadata Server] screen.

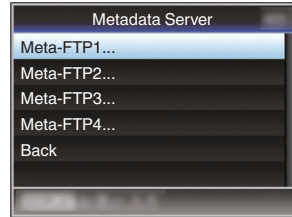

2 Register the [Metadata Server].

- Select a server using the cross-shaped button (▲▼), and press the Set button (●). The server settings screen appears. Perform setting for each item.
- Up to 4 settings can be registered. (P140 [Metadata Server])

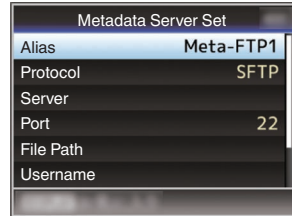

Memo : _____

- For details on the registered information, please consult the network administrator for the server.

Importing Metadata

Download the metadata settings file (XML format) from the FTP server.

- 1 Select [Main Menu] → [System] → [Network] → [Import Metadata] and press the Set button (●).

The [Import Metadata] screen appears.

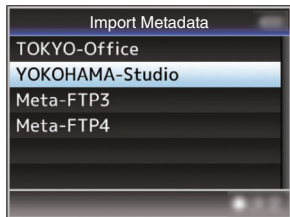

- 2 Select the server for importing the metadata.

- The name that is registered in [Metadata Server] → [Alias] is displayed.
- Select a server using the cross-shaped button (▲▼), and press the Set button (●).

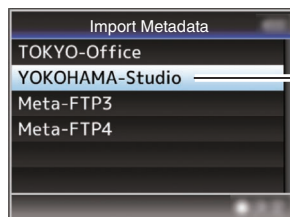

- 3 Select [Import] on the confirmation screen, and press the Set button (●).

Import starts.

After import is complete, the display is restored to the screen before the [Import Metadata] screen appears.

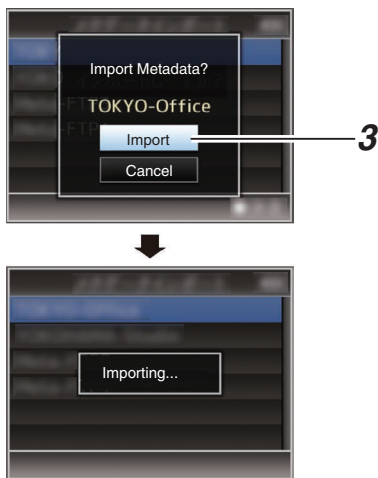

Memo :

- You cannot exit the menu or perform recording while import is in progress.
- If import of the metadata failed, "Import Error!" is displayed, and a message indicating the cause of the error appears. Press the Set button (●) to return to the [Import Metadata] screen in step 1.
(P203 [List of FTP Transfer Errors])
- When "HTTP" is selected in the [Select FTP Proxy] screen of the network connection setting, connections to the servers other than "FTP" protocol cannot be made.
- If a setting other than "FTP" is specified for [Protocol], to ensure the safety of the communication path, a screen appears prompting you to validate the fingerprint of the public key and certificate received from the server. Check to ensure that the displayed value coincides with the known value.

Uploading a Recorded Video Clip

Upload clips recorded in the SD card to a preset FTP server.

Configuring the FTP Server for Uploading

For specifying the settings (server name, user name, password, etc.) for connecting to the FTP server to upload recorded clips to as well as the directory of the upload destination.

1 Open the [Clip Server] screen.

Open the [Main Menu] → [System] → [Network]/[Settings] → [Clip Server] screen.

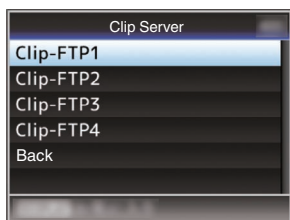

2 Register the [Clip Server].

Register the server to upload recorded clips in the SD card to.

Up to 4 servers can be registered.

(P140 [Clip Server])

Memo : _____

- For details on the registered information, please consult the network administrator for the server.

Uploading Video Clip

Upload clips recorded in the SD card to a preset FTP server.

All playable clips on the thumbnail screen can be uploaded.

Uploading a Video Clip

1 Set the camera recorder to the Media mode.

- Press and hold the [CAM/MEDIA] selection button in the Camera mode to enter the Media mode. A thumbnail screen of the clips recorded on the SD card is displayed.
- You can upload the selected clips on the thumbnail screen to the FTP server.

(P94 [Thumbnail Screen])

- #### 2 Move the cursor to the clip to be uploaded.
- Move the cursor to the clip to be uploaded using the cross-shaped button (▲▼◀▶).

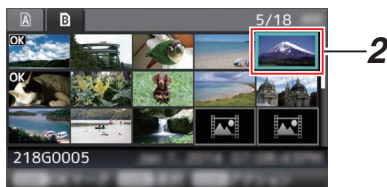

3 Press the [LOAD FILE/3] button.

The action selection screen is displayed.

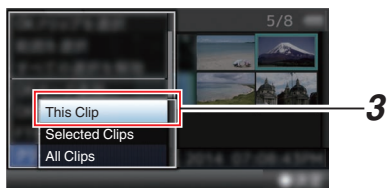

4 Select [FTP Upload] → [This Clip] → server to upload to, and press the Set button (●).

The status of the transfer process is indicated by a progress bar.

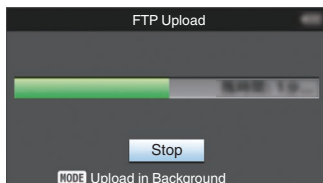

Memo : _____

- The name for the server to upload files to are indicated using the preset names in [Clip Server] → [Alias].
- To stop uploading, press the Set button (●). Select [Yes] on the confirmation screen, and press the Set button (●) to stop uploading and return to the thumbnail screen.

5 Upload is complete.

- After upload is complete, “Successfully Completed.” appears on the screen.
- Press the Set button (●) to return to the thumbnail screen.

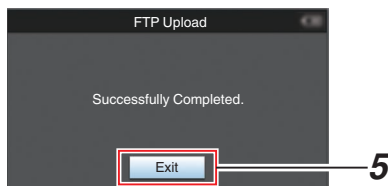

Selecting and Uploading Multiple Clips

To select and upload multiple clips, refer to “[Selecting and Performing Operations on Multiple Clips] (P 100)”.

Uploading All Video Clips

1 Press the [LOAD FILE/3] button.

The action selection screen is displayed.

2 Upload the clips.

Select [FTP Upload...] → [All Clips] → server to upload to, and press the Set button (●).

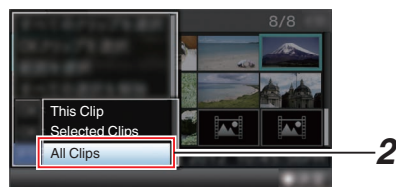

3 Upload starts.

The status of the transfer process is indicated by a progress bar.

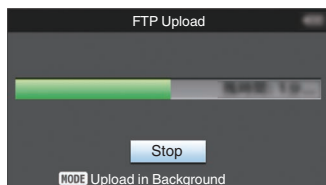

Memo : _____

- To stop uploading, press the Set button (●). Select [Yes] on the confirmation screen, and press the Set button (●) to stop uploading and return to the thumbnail screen.
 - If there already exists a file on the FTP server with a name identical to the file to be transferred, a confirmation screen asking to overwrite the file will appear. However, if “HTTP” is selected in the [Select FTP Proxy] screen of the network connection settings, an overwrite confirmation screen does not appear, and the existing file will be overwritten directly.
 - Even after uploading has started in step 3 (FTP transfer in progress), you can press the [CAM/MEDIA] selection button to perform shooting in the Camera mode.
 - If a setting other than “FTP” is specified for [Protocol], to ensure the safety of the communication path, a screen appears prompting you to validate the fingerprint of the public key and certificate received from the server. Check to ensure that the displayed value coincides with the known value.
 - Fingerprint is a unique value that varies with each public key and certificate.
 - For details of the fingerprint, please consult the administrator of the server to be connected.
- (P140 [Clip Server])
- When “HTTP” is selected in the [Select FTP Proxy] screen of the network connection setting, connections to the servers other than “FTP” protocol cannot be made.

4 Upload is complete.

- After all clips are uploaded successfully, “Successfully Completed.” is displayed. Press the Set button (●) to return to the thumbnail screen.
- When clips are not uploaded successfully, the following errors are displayed.

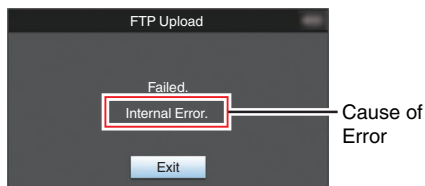

(☞ P203 [List of FTP Transfer Errors])

Memo : _____

- If a notification such as an error message appears after shifting to the Camera mode while FTP transfer is in progress, a  icon (yellow) will appear in the media's remaining level display area in the Camera mode. When the [CAM/MEDIA] selection button is pressed and held down to switch to the Media mode, the above error screen appears. Follow “[List of FTP Transfer Errors] (☞ P 203)” to clear the error message.

Connecting from a Web Browser

You can access the web functions of this camera recorder via a web browser on devices such as a smartphone, tablet terminal, or PC.

Make the necessary preparations for connection in advance.

(☞ P175 [Connect an appropriate adapter according to the intended use to the [HOST] terminal at the rear of the camera recorder.])

1 Set the camera recorder to the Camera mode, and display the [Network] (status) screen.

- Press the [STATUS] button on the camera recorder to display the status screen. Press the cross-shaped button (◀▶) to display the [Network] screen.
- Check the displayed [IP Address].

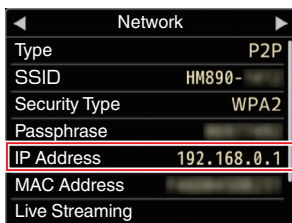

2 Start up the web browser on the terminal you wish to connect to the camera recorder, and enter the [IP Address] in the address field.

If “192.168.0.1” is displayed in [IP Address], enter “http://192.168.0.1”.



- 3 **Enter the user name and password.**
 Enter the user name (prohd) and the password (initial password: 0000) on the login screen to display the main page of the camera.

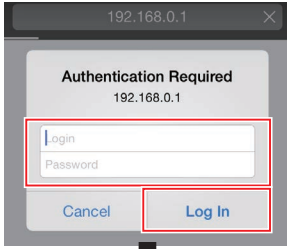

- Memo : _____
- The password can be altered in [Main Menu] → [System] → [Network]/[Settings] → [Web] → [Login Password].
 (☞ P137 [Login Password])

Editing Metadata

You can create the metadata to be inserted into a recorded file, or rewrite the metadata of a recorded clip.

Planning Metadata

You can access the page for editing the camera recorder's metadata via a web browser on devices such as a smartphone, tablet terminal, or PC, and edit the metadata that is to be applied to clips to be recorded.

- 1 **Access the main page of the camera.**
 Access the page via a web browser on devices such as a smartphone, tablet terminal, or PC. (☞ P182 [Connecting from a Web Browser])
- 2 **Display the Planning Metadata screen.**
 Tap (click) the [Planning Metadata] tab to open the [Planning Metadata] screen.



3 Edit the metadata.

- 1 Enter information for the necessary fields.
- 2 After input is complete, tap (click) [Save] to overwrite the metadata.

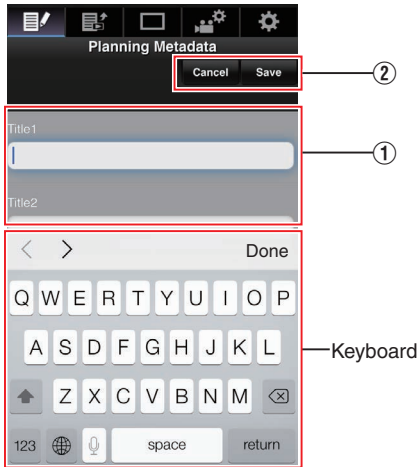

4 Tap (click) [OK] on the confirmation screen.

- Update of the [Planning Metadata] starts.
- After update is complete, “Renewal of planning metadata is succeeded.” is displayed. Tap (click) [OK].
- Returns to the screen in step 3.

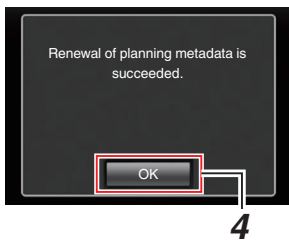

Memo : _____

- If update failed, “Renewal of planning metadata is failed.” is displayed.
Tap (click) [Close] to return to the screen of step 3.
- _____

Clip Metadata

You can access the page for editing the metadata via a web browser on devices such as a smartphone, tablet terminal, or PC, and display or rewrite the metadata that is recorded to a clip.

1 Access the main page of the camera.

Access the page via a web browser on devices such as a smartphone, tablet terminal, or PC. (P182 [Connecting from a Web Browser])

2 Display the clip list.

Tap (click) the [Clip List] tab to display the clip list.



3 Set the camera recorder to the “Remote Edit Mode”.

You can switch to “Remote Edit Mode” from a web browser or through operation of the camera.

■ Switching from a web browser

- ① You will see a message indicating "It is necessary to change the camera mode to "Remote Edit Mode". Change the mode." on the web browser.

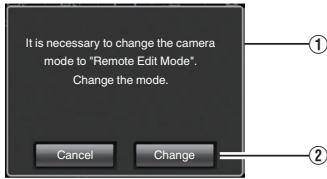

- ② Tap (click) [Change] to switch the camera to the Remote Edit mode.

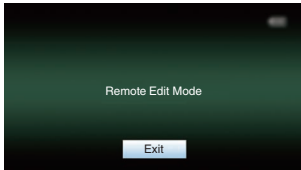

■ Switching from the camera

- ① "Change to Remote Edit Mode?" is displayed on the display screen of the camera unit.
- ② Select [Change] and press the Set button (●) to switch to the Remote Edit mode.

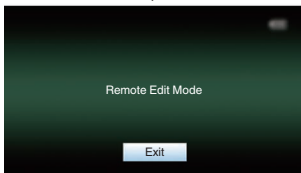
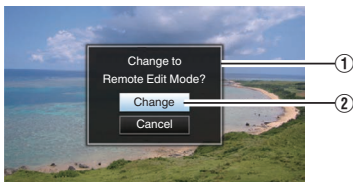

Memo : _____

- When the menu or status is displayed, display of the confirmation screen will be put on hold.
- If the menu is displayed on the camera recorder, close the menu.
- If the status is displayed on the camera recorder, close the status display.
- Pressing the Set button (●) on the camera recorder while in the Remote Edit Mode ends the Remote Edit Mode forcibly and switches to the Camera mode.
- When FTP upload via the camera unit is currently in progress, switching to the Remote Edit mode is disabled.

4 Select the Metadata Edit mode.

Select the [Metadata] tab.

5 Select the clip for which you want to rewrite the metadata.

- A list of the recorded clips appears on the [Clip List] screen.
- Tap (click) the clip for which you want to rewrite the metadata.

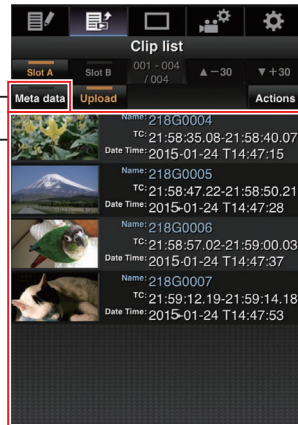

Memo : _____

- You can switch the displayed slot using the [Slot A] and [Slot B] tabs.
- You can use the [▲-30] or [▼+30] tab to jump to the previous or next 30 clips on the list.

6 Edit the metadata of the selected clips.

- 1 Edit the information for the necessary fields.
 - If you are using a PC, input using the mouse and keyboard.
 - If you are using a smartphone or tablet terminal, tap the text input area to display a standard software keyboard on the screen. Enter the information using the displayed keyboard.
- 2 You can tap (click) [OK Mark] to add an OK mark to or delete it from selected clips.
- 3 After editing is complete, tap (click) [Save] to overwrite the metadata.

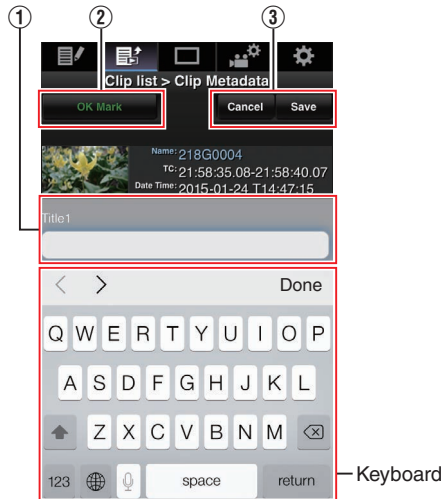

7 Tap (click) [OK] on the confirmation screen.

- Update of the metadata starts.
- After update is complete, “Renewal of clip metadata is succeeded.” is displayed. Tap (click) [OK].
- Returns to the screen in step 4.

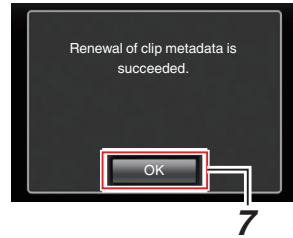

Memo : _____

- If update failed, “Renewal of clip metadata is failed.” is displayed. Tap (click) [Close] to return to the screen of step 4.

Uploading a Recording Clip via a Web Browser

- Upload clips recorded in the SD card to a preset FTP server.
- You can upload selected clips, all clips, or those appended with an OK mark.

Configuring the FTP Server for Uploading

(P180 [Configuring the FTP Server for Uploading])

Uploading Video Clips

- 1 Access the main page of the camera.**
Access the page via a web browser on devices such as a smartphone, tablet terminal, or PC. (P182 [Connecting from a Web Browser])
- 2 Display the clip list.**
Tap (click) the [Clip List] tab to display the clip list.



- 3 Set the camera recorder to the "Remote Edit Mode".**
You can switch to "Remote Edit Mode" from a web browser or through operation of the camera.

Switching from a web browser

- ① You will see a message indicating "It is necessary to change the camera mode to "Remote Edit Mode". Change the mode." on the web browser.

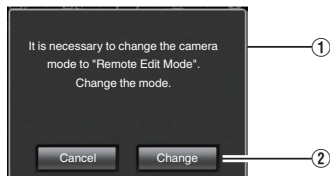

- ② Tap (click) [Change] to switch the camera to the Remote Edit mode.

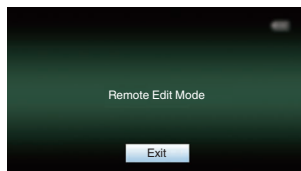

Switching from the camera

- ① "Change to Remote Edit Mode?" is displayed on the display screen of the camera unit.
- ② Select [Change] and press the Set button (●) to switch to the Remote Edit mode.

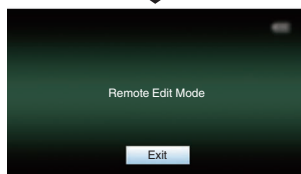
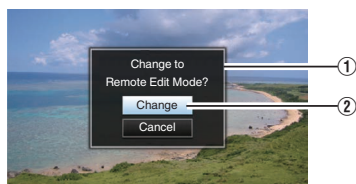

Memo : _____

- When the menu or status is displayed, display of the confirmation screen will be put on hold.
- If the menu is displayed on the camera recorder, close the menu.
- If the status is displayed on the camera recorder, close the status display.
- Pressing the Set button (●) on the camera recorder while in the Remote Edit Mode ends the Remote Edit Mode forcibly and switches to the Camera mode.
- When FTP upload via the camera unit is currently in progress, switching to the Remote Edit mode is disabled.

4 Select the Upload mode.

Select the [Upload] tab.

5 Select the clip you want to upload.

- A list of the recorded clips appears on the [Clip List] screen.
- Tap (click) the clip you want to upload to select it.
- Clips being selected are indicated by a check mark.

Memo : _____

- You can switch the displayed slot using the [Slot A] and [Slot B] tabs.
- You can use the [▲-30] or [▼+30] tab to jump to the previous or next 30 clips on the list.

6 Select the upload operation.

Tap (click) the [Actions] button.

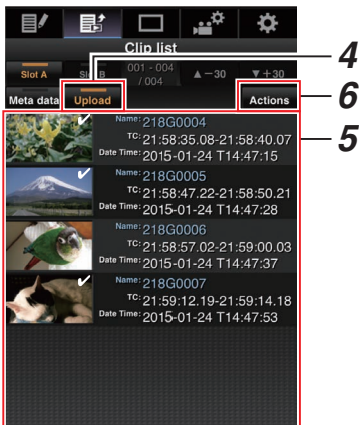

7 Select a method to upload the clips.

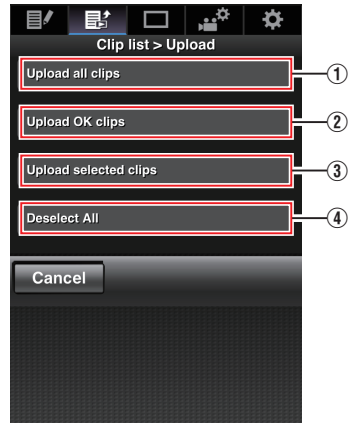

① Upload all clips

Uploads all the clips in the displayed slots. Tap (click) to move to the [Clip Server] screen.

② Upload OK clips

Uploads all clips in the displayed slots that are appended with an OK mark. Tap (click) to move to the [Clip Server] screen.

③ Upload selected clips

Uploads the clips you have selected. Tap (click) to move to the [Clip Server] screen.

④ Clear all selection

Clears all clip selection and returns to the [Clip List] screen.

8 Select the clip server and start uploading.

- Upon selecting the server to upload clips to, an upload screen appears.

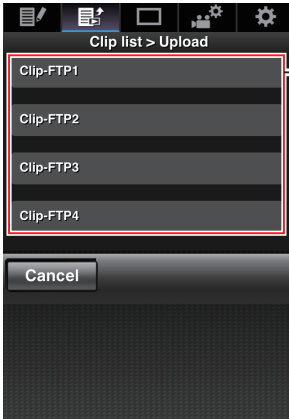

- The status of the transfer process is indicated by a progress bar.

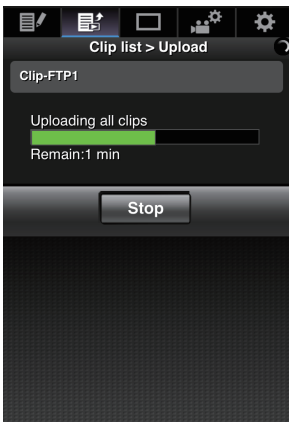

Memo : _____

- To stop transfer, tap (click) the [Stop] button. Tapping (clicking) [Yes] on the confirmation screen stops the transfer halfway and brings you back to the main page.
- If there already exists a file on the FTP server with a name identical to the file to be transferred, a confirmation screen asking to overwrite the file will appear. However, if "HTTP" is selected in the [Select FTP Proxy] screen of the network connection settings, an overwrite confirmation screen does not appear, and the existing file will be overwritten directly.
- After uploading in step 8 has started, other web browser operations are disabled until uploading is complete.
- After uploading in step 8 has started and upon shifting to the Media mode by pressing the [CAM/MEDIA] selection button, operation from the web browser will be disabled. To enable web browser operation, press the [CAM/MEDIA] selection button again to switch to the Camera mode.
- If a setting other than "FTP" is specified for [Protocol], to ensure the safety of the communication path, a screen appears prompting you to validate the fingerprint of the public key and certificate received from the server. Check to ensure that the displayed value coincides with the known value.
 - Fingerprint is a unique value that varies with each public key and certificate.
 - For details of the fingerprint, please consult the administrator of the server to be connected.
(P140 [Clip Server])
- When "HTTP" is selected in the [Select FTP Proxy] screen of the network connection setting, connections to the servers other than "FTP" protocol cannot be made.

9 Upload is complete.

- After upload is complete, "Successfully Completed." appears on the screen.

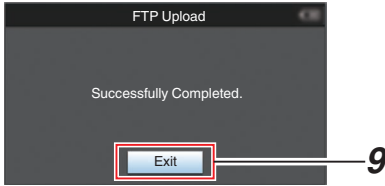

- When clips are not uploaded successfully, the following errors are displayed.

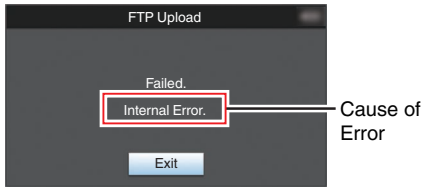

(☞ P203 [List of FTP Transfer Errors])

Memo : _____

- Follow "[List of FTP Transfer Errors] (☞ P 203)" to clear the error message.

View Remote Feature

You can access via a web browser on devices such as a smartphone, tablet terminal, or PC to check the live image and perform the following remote control operations.

- Start/stop recording
- Zooming
- Register/delete preset zoom

1 Access the main page of the camera.

Access the page via a web browser on devices such as a smartphone, tablet terminal, or PC. (☞ P182 [Connecting from a Web Browser])



2 Tap (click) the [View Remote] tab to open the [View Remote] screen.

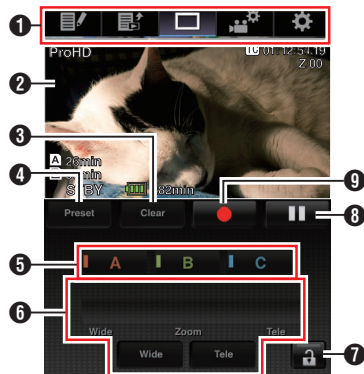

Operating Procedure



- 1 Page Switch Tab
Tap (click) to move to screen such as [Planning Metadata], [Clip List], [Settings].
- 2 Live View Screen
Displays the live images.
Tap a live image to display or hide information that is displayed on the live image, such as remaining space on the media and time code.
- 3 [Clear] Button
Switches to the Delete Preset Zoom Position mode.
(☞ P191 [Registering/Deleting Preset Zoom])
(☞ P192 [Deleting a Preset Zoom])
- 4 [Preset] Button
Switches to the Register Preset Zoom Position mode.
(☞ P191 [Registering Preset Zoom])
- 5 [A]/[B]/[C] Buttons
Use these buttons to perform preset registration or delete a preset data.
- 6 Zoom Control
 - Operate the zoom function by dragging the zoom button along the sliding bar.
 - Tap (click) the [Wide] or [Tele] button to fine-tune the zoom position.
- 7 Function Lock Button
Locks the functions that have been set on the [Settings] screen.
(☞ P195 [Changing View Remote Function Settings])

Icon	Description
	Locked
	Not locked

- 8 Stop Record Button
- 9 Start Record Button

Registering/Deleting Preset Zoom

Registering Preset Zoom

You can register any 3 zoom positions.

- 1 **Set to the Register Preset Zoom mode.**
Tap (click) the [Preset] button to switch to the Register Preset Zoom mode.

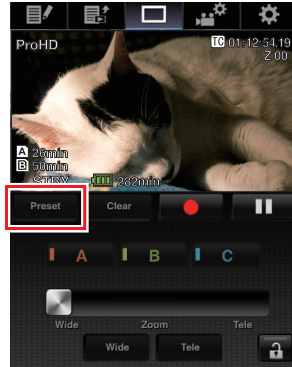

- 2 **Determine the zoom position.**
Use the zoom control to operate the zoom and determine a position.
- 3 **Tap (click) [A].**
Position [A] is registered, and position A is displayed on the sliding bar of the zoom control.

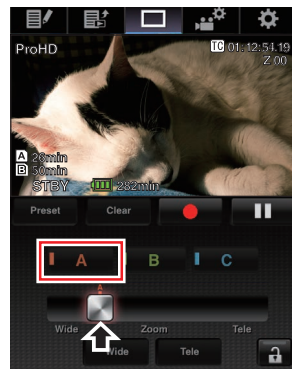

4 In the same way, register [B] and [C].

After all three positions A, B and C are registered, the positions of the [A], [B], and [C] buttons will be rearranged according to the order of the registered zoom position from the left.



5 Exit the Register Preset Zoom mode.

Tap (click) the [Preset] button to exit the Register Preset Zoom mode.

Memo :

- After registration is complete ([A], [B], and [C] buttons are all active), tapping (clicking) each button switches to the corresponding preset zoom position.
- This function operates independently of the preset zoom position on the camera recorder. (P52 [Saving/Recalling Current Zoom Position (Preset Zoom) LENS])

Deleting a Preset Zoom

1 Set to the Delete Preset Zoom mode.

When any of positions [A], [B], and [C] are registered, tapping (clicking) the [Clear] button switches to the Delete Preset Zoom mode.

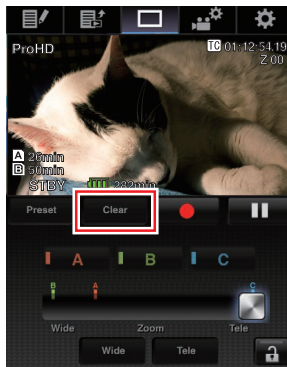

2 Tap (click) the [A], [B], or [C] button that corresponds to the position you want to delete.

- The position is deleted, and the button is grayed out.
- The corresponding zoom position mark on the sliding bar also disappears.

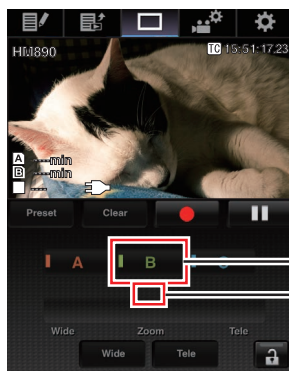

3 Exit the Delete Preset Zoom mode.

Tap (click) the [Clear] button to exit the Delete Preset Zoom mode.

Memo :

- The Clip Review function of the camera recorder is unavailable during View Remote operation. (P83 [Viewing Recorded Videos Immediately (Clip Review)])

Camera Control Function

You can control the camera by accessing via a web browser on devices such as a smartphone, tablet terminal, or PC.

You can perform the following operations for each of the items.



1 REC

For performing recording start or recording pause operation.



2 CAMERA

Enables operations related to the camera functions.

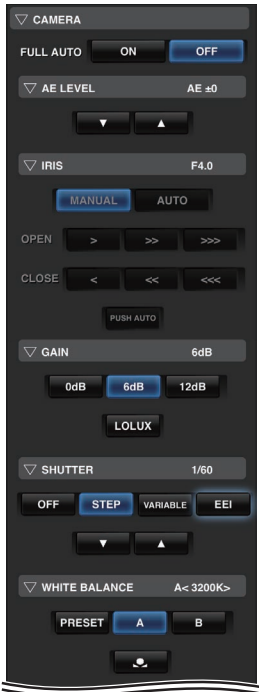

3 ZOOM

Enables zooming operations.

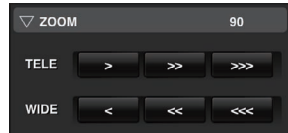

4 FOCUS

Enables focusing operations.



5 USER SWITCH

You can enable or disable the user buttons that are assigned with a function.

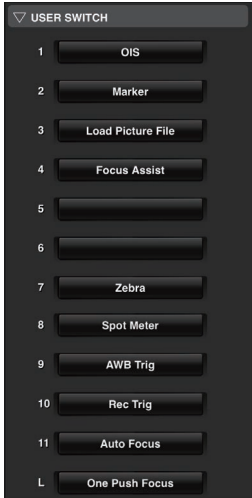

6 MENU

You can show or hide the display and menu characters on an external monitor as well as operation of menus, switching the display screen and status display.

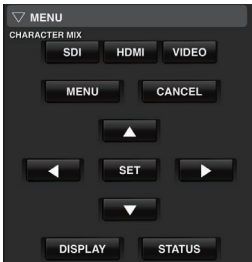

Changing the Settings via a Web Browser

You can change the network-related settings by accessing via a web browser on devices such as a smartphone, tablet terminal, or PC.

- 1 Access the main page of the camera.**
Access the page via a web browser on devices such as a smartphone, tablet terminal, or PC. (P182 [Connecting from a Web Browser])
- 2 Tap (click) the [Settings] tab.**



- 3 The [Settings] screen appears.**
Set each of the items as follows.

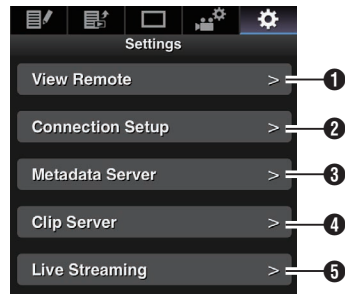

- 1 View Remote
Settings for operations on the View Remote.
- 2 Connection Setup
Settings related to the network.
You can change the settings for each of the preset items on the [Wizard] screen of the camera recorder.
- 3 Metadata Server
Settings on the server for importing the metadata.
Setting can be performed in the same way as the [Metadata Server] menu on the camera recorder.
The latest settings are reflected, regardless of whether they are specified via the camera recorder or web operation.
- 4 Clip Server
Settings for the server to upload recorded clips to.
Setting can be performed in the same way as the [Clip Server] menu on the camera recorder.
The latest settings are reflected, regardless of whether they are specified via the camera recorder or web operation.
- 5 Live Streaming
Setting for streaming audio and video via the network.
The latest settings are reflected, regardless of whether they are specified via the camera recorder or web operation.

Memo : _____

- Priority is given to menu operation on the camera recorder.
- When the menu on the camera recorder is opened while the [Settings] screen is opened using a web browser, a warning appears, after which the display returns to the main screen.
- While the menu is displayed on the camera recorder, the [Settings] screen cannot be opened via the web browser.

Changing View Remote Function Settings

For performing setting for using the View Remote function.

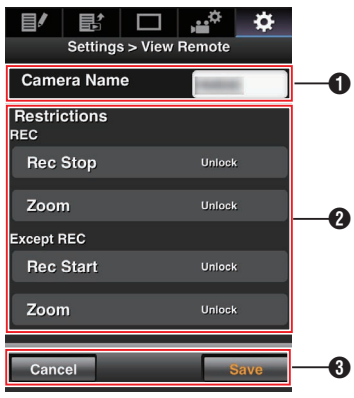

- 1 [Camera Name]
 - For setting the name that appears at the top left of the view screen.
 - Tapping the text input area displays a software keyboard.
If you are using a PC, enter using the PC keyboard.
 - By tapping the Go key after input is complete, the software keyboard disappears.
- 2 [Restrictions]

For setting the buttons to be disabled on the View screen while in the locked mode.

 - [REC]:
For setting whether to disable the Stop Record button or zoom operation during recording.
Tap (click) each item to switch between [Unlock] and [Lock].
 - [Except REC]:
For setting whether to disable the Record button or zoom operation in any operation other than during recording.
Tap (click) each item to switch between [Unlock] and [Lock].
- 3 [Save]/[Cancel]

Tap (click) [Save] to save the settings.
Tap (click) [Cancel] to stop setting and return to the main [Settings] screen.

Changing Connection Setup

You can change the settings for each of the preset items on the [Wizard] screen of the camera recorder.

- If all the items cannot be displayed in a single page, scroll down to display the remaining items.
- Items that cannot be changed are grayed out according to the type of adapter connected and the mode of connection.

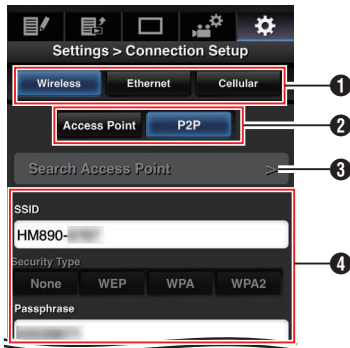

- 1 Type of Adapter Connected
- 2 Mode of Wireless LAN Connection
- 3 [Search Access Point] Button
Tap (click) to display a list of the detected access points.
The currently selected access point is indicated by a dot mark (•).

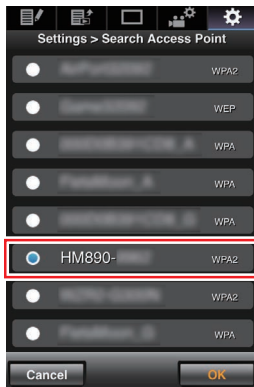

- 4 Settings during the use of wireless LAN

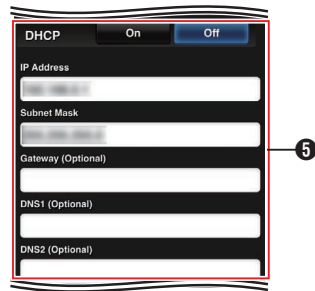

- 5 IP address settings
When "DHCP" is selected, all items will be grayed out.

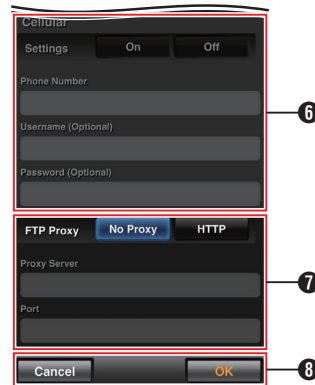

- 6 Settings when using a cellular adapter
- 7 Proxy settings when using FTP
- 8 [OK]/[Cancel] Button
After changing of settings is complete, tap (click) the [OK] button.
On the confirmation screen, tap (click) [Execute] to change the settings on the camera recorder and restart the network.

Changing Metadata Server Settings

You can make direct changes to the FTP server for importing the metadata set in [Main Menu] → [System] → [Network]/[Settings] → [Metadata Server], as well as the path of the file to import.

(☞ P140 [Metadata Server])

Changing Clip Server Settings

You can make direct changes to the server and directory settings that are specified in [Main Menu] → [System] → [Network]/[Settings] → [Clip Server] for uploading recorded clips in the SD card to the FTP server.

(☞ P140 [Clip Server])

Changing Streaming Settings

You can make direct changes to settings that are specified in [Main Menu] → [System] → [Network]/[Settings] → [Live Streaming Set], such as information on the destination of distribution.

(☞ P137 [Live Streaming Set])

Managing the Network Connection Settings File

This camera recorder allows you to save the network connection settings on the Wizard screen to the camera recorder unit.

Loading a saved connecting settings file enables you to reproduce the appropriate network connection state speedily.

Memo : _____

- To save or load the connection settings, go to [Main Menu] → [System] → [Network]/[Settings] → [Connection Setup].
- The following operations can be performed on the [Connection Setup] menu.
 - [Saving the Connection Settings File] (☞ P 197)
 - [Reading the Connection Settings File] (☞ P 198)
 - [Deleting Connection Settings] (☞ P 199)

Number of Storable Setup Files

Camera recorder : [CAM1] to [CAM4]

Saving the Connection Settings File

- 1 Select [Main Menu] → [System] → [Network]/[Settings] → [Connection Setup] and press the Set button (●).
- 2 Select [Store] and press the Set button (●).

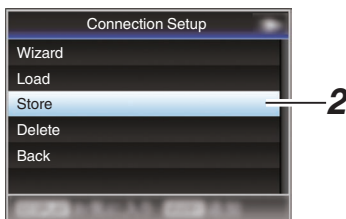

- 3 Select the file to be newly saved (or overwritten) using the cross-shaped button (▲▼), and press the Set button (●).



- 4 Name the file.
Enter the subtitle using the software keyboard.
(☞ P105 [Text Input with Software Keyboard])

Memo : _____

- When overwriting an existing file, the subtitle of the existing file is displayed.
- Select [Cancel] and press the Set button (●), or press the [CANCEL] button to return to the previous screen.

5 Select [Store] and press the Set button (●).



6 Save the file.

- A confirmation screen appears when you choose to overwrite. Select [Overwrite] on the confirmation screen, and press the Set button (●). Saving starts, and “Storing...” appears on the screen.

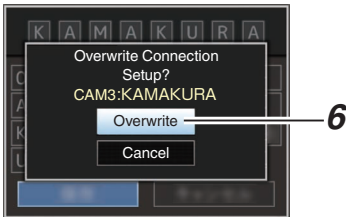

- Saving starts, and “Storing...” appears on the screen when the file is newly saved.



7 Saving is complete.

After saving of the file is complete, “Complete” appears on the screen, and the menu screen closes automatically.

Reading the Connection Settings File

- 1 Select [Main Menu] → [System] → [Network]/[Settings] → [Connection Setup] and press the Set button (●).
- 2 Select [Load] and press the Set button (●).

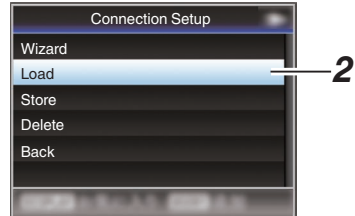

- 3 Select the file to read using the cross-shaped button (▲▼), and press the Set button (●).



- 4 Select [Load] on the confirmation screen, and press the Set button (●).

Loading starts, and “Loading...” appears on the screen.

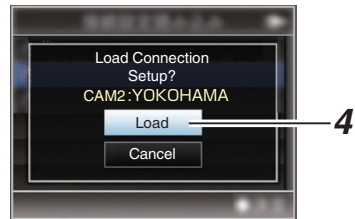

5 Reading is complete.

After reading of the file is complete, “Complete” appears on the screen, and the menu screen closes automatically.

Deleting Connection Settings

- 1 Select [Main Menu] → [System] → [Network]/[Settings] → [Connection Setup] and press the Set button (●).
- 2 Select [Delete] and press the Set button (●).

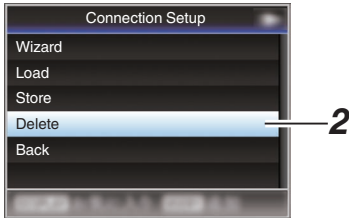

- 3 Select the file to delete using the cross-shaped button (▲▼), and press the Set button (●).



- 4 Select [Delete] on the confirmation screen, and press the Set button (●). Deletion starts, and “Deleting...” appears on the screen.

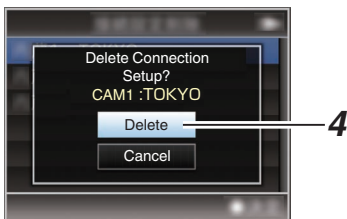

- 5 Deletion is complete. After file deletion is complete, “Complete” appears on the screen.

Performing Live Streaming

By combining with a decoder device or PC application that support live streaming, you can perform audio and video streaming via the network.

Supported Formats

Video

H.264

- 1920x1080/60i (8.0M), 60i (5.0M), 60i (2.5M), 50i (8.0M), 50i (5.0M), 50i (2.5M)
- 1280x720/30p (5.0M), 30p (3.0M), 30p (1.5M), 25p (5.0M), 25p (3.0M), 25p (1.5M)
- 720x480/60i (5.0M), 60i (3.0M), 60i (1.5M), 60i (0.8M), 60i (0.3M), 60i (0.2M)
- 720x576/50i (5.0M), 50i (3.0M), 50i (1.5M), 50i (0.8M), 50i (0.3M), 50i (0.2M)
- 480x270/30p (0.2M), 25p (0.2M)

Memo :

- The following constraints apply depending on the setting of [Main Menu] → [System] → [Network]/[Settings] → [Live Streaming Set] → [Type].
 - An encoding bit rate exceeding 5.0 Mbps cannot be selected in the case of “RTSP/ RTP”.
 - An encoding bit rate exceeding 3.0 Mbps cannot be selected in the case of “ZIXI”. (☞ P139 [Type])

Audio

AAC

Supported Protocols

Network protocols	:	TCP, UDP
Transport mode	:	MPEG2-TS, RTSP/RTP, ZIXI

Setting Distribution

- 1 Set the [Record Format] according to the resolution and frame rate of the video to be distributed.

			Settable Resolution during Streaming/No. of Frames			
			1920x1080	1280x720	720x480 720x576	480x270
Record Format Resolution/No. of Frames	1920x1080	60i,30p	60i	30p(*)	60i	30p
		50i,25p	50i	25p(*)	50i	25p
	1440x1080	60i	60i	30p(*)	60i	30p
		50i	50i	25p(*)	50i	25p
	1280x720	60p,30p	—	30p	60i	30p
		50p,25p	—	25p	50i	25p
	720x480 (U model)	60i	—	—	60i	30p
	720x576 (E model)	50i	—	—	50i	25p

- * This item cannot be selected when [Main Menu] → [System] → [Record Set] → [Record Format] → [System] is set to “HD(SDI In)”.

Memo : _____

- Live streaming cannot be performed in the following cases.
 - When [Main Menu] → [System] → [Record Set] → [Record Format] → [System] is set to “HD+SD” or “HD+Web”
 - When [Main Menu] → [System] → [Record Set] → [Record Format] → [A]Frame & Bit Rate is set to “24p”

- 2 Set the Resolution and Frame & Bit Rate for the video to be distributed.

Specify the settings in [Main Menu] → [System] → [Network]/[Settings] → [Live Streaming Set].
(☞ P137 [Live Streaming Set])

- 3 Set the distribution protocol.

Specify the settings in [Main Menu] → [System] → [Network]/[Settings] → [Live Streaming Set] → [Type].
(☞ P139 [Type])

- 4 Set items related to the distribution protocol.

Set each of the [Main Menu] → [System] → [Network]/[Settings] → [Live Streaming Set] → [UDP/TCP Settings]/[RTSP/RTP Settings]/[ZIXI Settings] items.
(☞ P139 [UDP/TCP Settings])
(☞ P139 [RTSP/RTP Settings])
(☞ P139 [ZIXI Settings])

Starting Distribution

- 1 Perform the necessary settings for the decoder device or the PC application.

For details on the settings, please refer to the “INSTRUCTIONS” of the respective devices and applications.

Memo : _____

- If there is a NAT router within the communication path between the camera and the decoder, port forwarding setup is required. For details on the settings, please refer to the “INSTRUCTIONS” of the router in use.
- The following parameters are required when connecting to this camera recorder using the RTSP/RTP.
Port number: 554
Stream ID: stream
- Use the following to access via URL.
rtsp://<IP address of the camera recorder>:554/stream

- 2 With the network connection established, set [Live Streaming] to “On”.

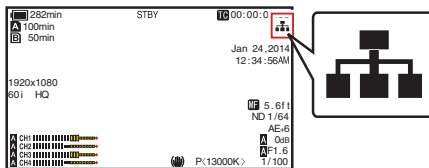

(☞ P174 [Preparing Network Connection])

- Set [Main Menu] → [System] → [Network]/[Settings] → [Live Streaming Set] → [Live Streaming] to “On”.
- The network connection mark appears on the display screen when a network connection is established.



Memo : _____

- You can also assign “Live Streaming” to a user button.
(☞ P42 [Assignment of Functions to User Buttons])
- You can view the status of distribution on the LCD monitor.
(☞ P150 [Live streaming mark])

Icon	Status
 (Red)	<ul style="list-style-type: none">• Distribution in progress (good connection quality)• Blinks when distribution starts or stops
 (Red)	Distribution in progress (poor connection quality)
 (Yellow)	Waiting for connection (during RTSP/RTP) or connection failed

- When the  icon is displayed, you can view the details of the error on the [Network] screen of the status screen.

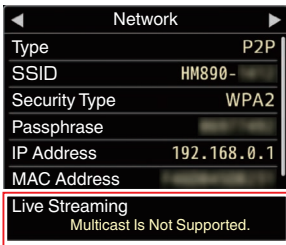

(☞ P205 [List of Live Streaming Error Displays])

Caution : _____

- Streaming may be interrupted temporarily 24 hours after the process started.

Error Messages and Actions

Warning display on the LCD monitor and viewfinder screen, tally lamp indication and warning tone are as follows according to the error status.

Memo : _____

- This camera recorder makes use of a microcomputer. Noise interference from external sources may prevent it from functioning properly. When this occurs, turn off and on the power of the camera recorder again.

Error Message	Status	Action
Turn Power Off Turn Back On Later	System error. * The warning tone sounds and the tally lamp blinks twice every second.	Turn off the power, and turn it on again. If the error persists, please contact the local dealers in your area.
Fan Stop Detected Please Turn P.Off	The fan stopped running.	Please contact the local dealers in your area.
Fan Maintenance Required	Usage time of the fan has exceeded 9000 hours.	Check the fan and replace accordingly. For more details, please contact the local dealers in your area. Memo : _____ <ul style="list-style-type: none"> • You can check the usage time of the fan in [System] ➔ [System Information] ➔ [Fan Hour]. (☞ P132 [Fan Hour])
Getting Overheated. Please Turn Power Off.	<ul style="list-style-type: none"> • The battery has exceeded the specified temperature. • The power turns off automatically after about 15 second. 	<ul style="list-style-type: none"> • Wait until the temperature drops or replace the battery. • If the error persists, please contact the local dealers in your area.
Rec Inhibited	[REC] button is pressed when the write-protect switch of the SD card is set.	Turn off the write-protect switch of the SD card, or insert a recordable SD card. (☞ P43 [SD Card])
Lost Media Info * (*: A, B)	<ul style="list-style-type: none"> • Card is removed while recording is in progress. • Card is removed while formatting is in progress. • Card is removed while restoring is in progress. • Card is removed while adding the OK mark. • Card is removed while writing a setup file. • Card is removed while deleting a clip. 	Restore the card using this camera recorder. (☞ P46 [Restoring and Updating the SD Card])

Error Message	Status	Action
Record Format Incorrect	Video format of the file for Clip Review is different from the current [A Resolution] and [A Frame & Bit Rate] setting.	Set [A Resolution] and [A Frame & Bit Rate] correctly. (☞ P133 [A Resolution]) (☞ P133 [A Frame & Bit Rate])
Media Full	<ul style="list-style-type: none"> [REC] button is pressed when the media in use has no remaining space. Remaining space ran out during recording. 	Replace the SD card with a new one.
No Clips	No viewable clips are found on the card for Clip Review.	Insert an SD card that contains clips that can be reviewed. (☞ P43 [SD Card]) (☞ P83 [Viewing Recorded Videos Immediately (Clip Review)]))
No Media	[REC] button is pressed when an SD card is not inserted.	Insert an SD card. (☞ P43 [SD Card])
No Media	No SD card is found in Media mode or when the thumbnail screen is displayed.	Insert an SD card. (☞ P43 [SD Card])
No Clips	No clips are found on the inserted SD card in Media mode or when the thumbnail screen is displayed.	Insert an SD card that contains playable clips. (☞ P43 [SD Card]) (☞ P94 [Playing Recorded Clips])
12h Continuation Record	The continuous recording time in AVCHD mode exceeds 12 hours and recording stops automatically.	To continue recording, press the [REC] button again.

Memo : _____

- Please see below for error messages when auto white balance adjustment failed to complete.
(☞ P64 [Adjusting the White Balance])

List of FTP Transfer Errors

If the upload of a recorded clip or download of the metadata setup file (XML format) is not successfully completed, the following errors are displayed.

Error message	Status	Action
Timeout.	Transfer was discontinued due to timeout caused by network transmission or server failure.	<ul style="list-style-type: none"> Execute again. Use a different server.
Media Was Removed.	SD card is removed while FTP transfer is in progress.	Insert the SD card and execute FTP transfer again.
Adapter Was Removed.	The USB network adapter is removed while FTP transfer is in progress.	Connect the USB network adapter.
Cannot Connect to Server.	Unable to connect to the FTP server.	Adjust the Server and Port settings for [Metadata Server] or [Clip Server]. (☞ P140 [Metadata Server]) (☞ P140 [Clip Server])

Error message	Status	Action
Access Denied.	Access is denied.	Adjust the Server and Port settings for [Metadata Server] or [Clip Server]. (☞ P140 [Metadata Server]) (☞ P140 [Clip Server])
Invalid Username or Password.	Authentication for login to the FTP server failed.	Adjust the Username and Password settings for [Metadata Server] or [Clip Server]. (☞ P140 [Metadata Server]) (☞ P140 [Clip Server])
Invalid Path Was Requested.	The path specified for the FTP server is incorrect.	Adjust the [Clip Server] and [Dir. Path] settings for [Metadata Server] or [File Path]. (☞ P140 [Metadata Server]) (☞ P140 [Clip Server])
Server Error.	There was an unintended operation of the FTP server.	Execute again. Use a different server.
Invalid Request.	A bad request is executed for the FTP server.	Use a different server.
Invalid Data Size.	Invalid data size, such as a planning metadata size that exceeds 4 KB.	Adjust the planning metadata saved in the Metadata Server. (☞ P183 [Planning Metadata])
Invalid Data Format.	The XML format of the planning metadata is invalid.	Adjust the planning metadata saved in the Metadata Server. (☞ P183 [Planning Metadata])
Transfer Error.	Transfer failed due to communication failure.	Execute again.
Invalid URL.	The path was deemed invalid by the FTP server.	Adjust the Server and Port settings for [Metadata Server] or [Clip Server]. (☞ P140 [Metadata Server]) (☞ P140 [Clip Server])
Media Access Error.	Reading/writing of the SD card failed while FTP transfer is in progress.	Insert a different SD card.
Internal Error.	An internal error has occurred while FTP transfer is in progress.	Adjust the settings and execute again.
Other Error.	An unknown error or other errors have occurred while FTP transfer is in progress.	Adjust the settings and execute again.
Media Read Error.	Reading of the SD card failed while FTP transfer is in progress.	Insert a different SD card.

List of Live Streaming Error Displays

The following error messages are displayed when the live streaming setting is incorrect, or when the connection is lost during live streaming.

Error message	Status	Action
Invalid Address	<ul style="list-style-type: none"> The IP address format is incorrect. The domain name cannot be converted into the IP address. 	<ul style="list-style-type: none"> Enter the IP address or host name of the destination correctly. (☞ P200 [Setting Distribution])
Multicast Is Not Supported	An IP multicast address was set.	Use an IP address that is not a multicast address.
Cannot Connect to Receiver	Establishment of connection with TCP failed.	<ul style="list-style-type: none"> Ensure that the recipient's device is set to TCP. Change the Type item to "MPEG2-TS/UDP". (☞ P200 [Setting Distribution])
TCP Disconnected	TCP connection is lost.	Check to ensure that there is no abnormality in the decoder, or network connection device and cables, followed by establishing the connection again.
Not Enough Bandwidth	<ul style="list-style-type: none"> The communication bandwidth is narrower than the average bit rate. The network bandwidth is insufficient, and packets are discarded. 	<ul style="list-style-type: none"> Lower the resolution/picture quality of the video to be distributed. Consider switching to the use of a stable network, such as wired LAN.
Connection Timeout	Timeout for connection via ZIXI.	Set [Destination Address] and [Destination Port] correctly. (☞ P200 [Setting Distribution])
Authorization Failed	Authentication of connection via ZIXI failed.	Set [Stream ID] and [Password] correctly. (☞ P200 [Setting Distribution])
Connection Error	Connection via ZIXI failed.	Check whether a different camera with an identical stream ID is connected.
Disconnected	ZIXI connection is lost.	Check whether there is abnormality with the network connection device, cables, etc., and try to re-establish the connection.

Blinking of the Tally Lamp

The tally lamp start blinking when the remaining space on the SD card is running out during recording, or when the battery power is running low.

(Common for front and back tally lamps)

Blinking Mode	Remaining Battery Power/SD Card Space
Blinks slowly (once every second)	<ul style="list-style-type: none"> Battery power is low Remaining recording time on SD card is less than 3 minutes (during recording) When a malfunction occurred during live streaming
Blinks quickly (2 times per second)	<ul style="list-style-type: none"> Remaining battery power is almost zero Remaining recording time on SD card is zero (during recording) Error on the camera recorder

Warning Tone

- Warning tone is output from the monitor speaker and [PHONES] terminal when the battery level is low.
- Warning tone is also output when an error occurs in the camera recorder.

Memo :

- You can specify whether to turn on the warning tone as well as setting the volume in [A/V Set] → [Audio Set] → [Alarm Level].
(☞ P129 [Alarm Level])

Troubleshooting

Symptom	Action
Power does not turn on.	<ul style="list-style-type: none"> Is the power supply or battery properly connected? Is the battery charged? Is the power turned on immediately after it is turned off? Make sure to wait for an interval of at least 5 seconds before turning on the power again.
Unable to start recording.	<ul style="list-style-type: none"> Is the record trigger button/lock switch on the handle turned on? Is the write-protect switch of the SD card turned on? Make sure that the write-protect switch is turned off. (☞ P43 [Write-Protect Switch on the SD Card]) Is the camera recorder set to the Camera mode? Press the [CAM/MEDIA] selection button to switch to the Camera mode. (☞ P18 [Operation Modes])
Camera image is not output on the LCD monitor and viewfinder screen.	<ul style="list-style-type: none"> Is the camera recorder set to the Camera mode? Press the [CAM/MEDIA] selection button to switch to the Camera mode. (☞ P18 [Operation Modes])
Playback does not start after selecting a clip thumbnail and pressing the Set button (●).	<ul style="list-style-type: none"> Is the selected clip a playable clip? Playback is not possible if the clip has a different video format setting.

Symptom	Action
No sound during playback.	<ul style="list-style-type: none"> Is the currently played clip recorded in the Variable Frame Rec mode? (P93 [Variable Frame Rec])
Images on the LCD monitor and viewfinder screen appear dark or blurred.	<ul style="list-style-type: none"> Readjust the brightness of the LCD monitor and viewfinder. Is the [ND FILTER] switch set to "1/64"? Is the iris closed? Is the shutter speed setting too high? Is the amount of peaking too little? Use the [PEAKING +/-] button to adjust the contour for the LCD monitor and the viewfinder screen. (P39 [Adjusting the LCD Monitor]) (P40 [Adjusting the Viewfinder])
The [CH-1/CH-2] recording level adjustment knob does not work.	<ul style="list-style-type: none"> Is the [CH-1/CH-2 AUTO/MANUAL] switch set to "AUTO"? Is the [FULL AUTO] switch set to "ON"? Is the [FULL AUTO] switch set to "ON", and [Camera Function] → [FULL AUTO] → [Audio] set to "Auto"? (P114 [Audio])
[CH-3/CH-4] audio is not recorded.	<ul style="list-style-type: none"> Is the number of recording channels set to "4ch"? (P133 [A Audio]) (P134 [B Audio]) Is [System] → [Record Set] → [Record Format] → [A Format]/[B Format] set to "AVCHD"? Select a setting other than "AVCHD". (P133 [A Format]) (P134 [B Format])
SD card cannot be initialized (formatted).	<ul style="list-style-type: none"> Is the write-protect switch of the SD card turned on? Make sure that the write-protect switch is turned off. (P43 [Write-Protect Switch on the SD Card])
Battery alarm appears even after loading a charged battery.	<ul style="list-style-type: none"> Is the battery too old?
Menu cannot be operated.	<ul style="list-style-type: none"> Is the Menu Lock mode turned on? (P106 [About the Menu Lock Feature])
The time code and user's bit are not displayed.	<ul style="list-style-type: none"> Even in Camera mode or Media mode, the time code and user's bit may not be displayed depending to the type of display. Is [LCD/VF] → [Display Settings] → [TC/UB] set to "Off"? To display the time code or user's bit, set it to "TC" or "UB". (P123 [TC/UB])
The date and time are not displayed.	<ul style="list-style-type: none"> The date and time are only displayed on the Display 1 and Display 2 screens in the Camera mode (during shooting). (P145 [Display Screen in Camera Mode]) Is [System] → [Record Set] → [Time Stamp] set to "On"? To display the date and time, set it to "Off". (P136 [Time Stamp])

Symptom	Action
Incorrect display on the viewfinder.	<ul style="list-style-type: none"> Is the LCD monitor used with [LCD/VF] → [LCD + VF] set to “Off”? (☞ P120 [LCD + VF])
The actual recording time is shorter than the estimated time.	<ul style="list-style-type: none"> The recordable time may be shorter depending on the shooting conditions or the subject.
The two camera recorders are not synchronized even though the time codes have been synchronized. (L on the Slave device is not displayed.)	<ul style="list-style-type: none"> Is the [TC GENE.] switch set to “FREE”? (☞ P78 [Synchronizing the Time Code with an External Time Code Generator]) Set [System] → [Record Set] → [Record Format] → [A]Frame & Bit Rate such that the two camera recorders have the same frame rate. (☞ P133 [A Frame & Bit Rate])
Cannot connect to wireless LAN.	<ul style="list-style-type: none"> Check the mode of connection and method of setting ([SSID] and [Passphrase] in cases other than WPS). (☞ P175 [Connecting via Wireless LAN]) Even if the Passphrase is wrong, “Completed the Setup Wizard. Please Input the Passphrase into Your Device.” may appear at the browser setting depending on the type of encryption. Adjust [Passphrase] again.
The View Remote screen turns black. The screen flickers. The screen freezes. Cannot perform remote operation.	<ul style="list-style-type: none"> The network path is congested. Wait a while before refreshing (reloading) the web browser. The problem may be resolved by clearing the web browser cache.
The clips cannot be uploaded to the FTP server.	<ul style="list-style-type: none"> Adjust the [Clip Server] settings. (☞ P140 [Clip Server]) The maximum size of the recorded clip is 64 GB. If a file size limit is set in the FTP server settings, set the size limit to more than 64 GB. Take necessary action as described in “[List of FTP Transfer Errors]” (☞ P 203).
The wireless LAN is disconnected.	<ul style="list-style-type: none"> The wireless LAN may be disconnected depending on the environment. Change the usage environment. Connect via wired LAN. (☞ P177 [Connecting via Wired LAN])
GPS signal cannot be received. GPS	<ul style="list-style-type: none"> Signal reception from GPS satellites may be affected by buildings or trees. Perform positioning preferably at an unobstructed location with a clear view. Radio wave reception may be affected by weather conditions such as on a cloudy or rainy day.
The position is not accurate. GPS	<ul style="list-style-type: none"> The precision error may be up to hundreds of meters if the GPS signal is weak or reflected off surrounding buildings.

Specifications

Terminal Section

General

Item	Description
Power	When using an external power source: DC 10.5 V to 17.0 V When using a battery: DC 14.4 V (Anton/Bauer, IDX)
Power consumption	Approx. 21.0 W (during recording [camera recorder + supplied lens] while using the viewfinder)
Mass	
GY-HM890U	3.95 kg (*1)
GY-HM890E GY-HM890RE	4.15 kg (*1)
GY-HM890CHU	2.7 kg (*2)
GY-HM890CHE GY-HM890RCHE	2.9 kg (*2)
GY-HM850U	3.9 kg (*1)
GY-HM850E GY-HM850RE	4.1 kg (*1)
GY-HM850CHU	2.65 kg (*2)
GY-HM850CHE GY-HM850RCHE	2.85 kg (*2)
Allowable operating temperature	0 °C to 40 °C (32 °F to 104 °F)
Allowable operating humidity	35 %RH to 80 %RH
Allowable storage temperature	-20 °C to 50 °C (-4 °F to 122 °F)

*1 Camera recorder (including microphone and viewfinder) and supplied lens

*2 Camera recorder (including microphone and viewfinder) only

Video/Audio

Item	Description
[HD/SD SDI OUT] Terminal (BNC)	
HD-SDI (1080i/720p)	Compliant with SMPTE 292 M
SD-SDI	Compliant with SMPTE 259 M
3G-SDI	Compliant with SMPTE 424 M
HD-SDI embedded audio standard	Compliant with SMPTE 299 M
SD-SDI embedded audio standard	Compliant with SMPTE 272 M
3G-SDI embedded audio standard	Compliant with SMPTE 299 M
[HD/SD SDI IN] Terminal (BNC) 890 890CH	
HD-SDI (1080i/720p)	Compliant with SMPTE 292 M
SD-SDI	Compliant with SMPTE 259 M
HD-SDI embedded audio standard	Compliant with SMPTE 299 M
SD-SDI embedded audio standard	Compliant with SMPTE 272 M
[VIDEO OUT] Terminal (BNC)	1.0 V (p-p), 75 Ω (unbalanced)
[HDMI] Output Terminal	Type A
[INPUT1/INPUT2] Terminal (XLR 3-pin)	
[MIC]	-50 dBu, 3 kΩ, XLR (balanced), +48 V output (phantom power supply)
[LINE]	+4 dBu, 10 kΩ, XLR (balanced)
[AUX] Terminal	-22 dBu, 10 kΩ, 3.5 mm stereo mini jack (unbalanced)
[AUDIO OUTPUT CH-1/CH-3] Terminal	-8 ± 1 dBu (during reference level input), 1 kΩ (unbalanced)
[AUDIO OUTPUT CH-2/CH-4] Terminal	-8 ± 1 dBu (during reference level input), 1 kΩ (unbalanced)
[PHONES] Terminal	Φ3.5 mm stereo mini jack (unbalanced) x 2

Others

Item	Description
[GENLOCK] Terminal	1.0 V (p-p), 75 Ω
[DEVICE] Terminal	Mini USB-B type, USB 2.0, miniB, slave function (mass storage class) only
[HOST] Terminal	USB-A type, USB2.0, network connection function only, 5 V/0.5 A
[REMOTE1] Terminal	miniDin 6-pin
[REMOTE2] Terminal	Φ2.5 mm wired remote control
[TC IN] Terminal	1.0 V(p-p) to 4.0 V(p-p) high impedance
[TC OUT] Terminal	1.0 V(p-p) to 4.0 V(p-p) low impedance
[STUDIO] Terminal 890 890CH	miniDin
[DC INPUT] Terminal	XLR 4-pin

Lens Section **890** **850**

Item	Description
Lens	F1.6 (wide-angle) to F3.0 (telephoto) f = 4.1 mm to 82.0 mm (Conversion to 35 mm camera format: f = 29 mm to 580 mm)
Filter Diameter	Φ72 mm

Camera Section

Item	Description
Image pickup device	1/3-inch, 2.2 megapixels, progressive CMOS x 3
Color separation prism	F1.6, 3-color separation prism
Sensitivity	F11, 2000 lx (standard value: 60 Hz)
Sync system	External/Internal Synchronization (Built-in SSG)
Optical filter	OFF, 1/4, 1/16, 1/64
Gain	-6 dB, -3 dB, 0 dB, 3 dB, 6 dB, 9 dB, 12 dB, 15 dB, 18 dB, 21 dB, 24 dB, Lolux (30 dB, 36 dB), ALC
Electronic shutter	1/4 to 1/10000, EEI
Variable Frame Rate	2/30-60/30fps, 2/25-50/25fps, 2/24-60/24fps
LCD monitor	4.3-inch LCD, 1.15 megapixels
Viewfinder	0.45-inch LCOS, 1.22M pixels (852 x 480 x 3)

Storage Section

Item	Description
Supported media	SDHC/SDXC memory card (Class 4/6/10) * Class 4 supports only AVCHD/SD/Web formats.
Slots	x 2

Video/Audio

Item	Description
HD mode (MOV/MP4/MXF: MPEG-2)	
Video recording file format	QuickTime File Format (For Final Cut Pro)/MP4 File Format/MXF File Format
Video	
HQ Mode	MPEG-2 Long GOP VBR, 35 Mbps (Max) MP@HL, 1920x1080/59.94i, 29.97p, 23.98p, 50i, 25p, 1440x1080/59.94i, 50i, 1280x720/59.94p, 29.97p, 23.98p, 50p, 25p
SP Mode	MPEG-2 Long GOP CBR, 18.3 Mbps MP@HL (720 p)/25 Mbps MP@H14 (1080i) 1440x1080/59.94i, 50i, 1280x720/59.94p, 50p
Audio	LPCM 2ch/4ch, 48 kHz/16 bits
HD Mode (AVCHD)	
Video recording file format	AVCHD File Format
Video	
HQ Mode (Progressive)	MPEG-4 AVC/H.264, 28 Mbps (Max) 1920x1080/59.94p, 50p
HQ Mode	MPEG-4 AVC/H.264, 24 Mbps (Max) 1920x1080/59.94i, 50i
SP Mode	MPEG-4 AVC/H.264, 17 Mbps 1920x1080/59.94i, 50i
LP Mode	MPEG-4 AVC/H.264, 9 Mbps 1440x1080/59.94i, 50i
EP Mode	MPEG-4 AVC/H.264, 5 Mbps 1440x1080/59.94i, 50i
Audio	Dolby Digital 2ch, 48 kHz/16 bits, 256 kbps

Item	Description
HD Mode (MOV: H.264)	
Video recording file format	QuickTime File Format
Video	
XHQ Mode	MPEG-4 AVC/H.264, 50 Mbps 1920x1080/59.94p, 59.94i, 29.97p, 23.98p, 50p, 50i, 25p
UHQ Mode	MPEG-4 AVC/H.264, 35 Mbps (Max) 1920x1080/59.94i, 29.97p, 23.98p, 50i, 25p
Audio	LPCM 2ch/4ch, 48 kHz/16 bits
SD mode (MOV: H.264)	
Video recording file format	QuickTime File Format
Video	MPEG-4 AVC/H.264, 8 Mbps 720x480/59.94i (U model) 720x576/50i (E model)
Audio	LPCM 2ch/4ch, 48 kHz/16 bits
Web Mode (MOV: H.264)	
Video recording file format	QuickTime File Format
Video	
HQ Mode	MPEG-4 AVC/H.264, 3 Mbps 960x540/29.97p, 23.98p, 25p
LP Mode	MPEG-4 AVC/H.264, 1.2 Mbps 480x270/29.97p, 23.98p, 25p
Audio	μ-law 2ch/4ch, 16 kHz
Streaming Mode	1920x1080(59.94i/50i) Audio AAC128 k 8/5/2.5 Mbps 1280x720(29.97p/25p) Audio AAC128 k 5/3/1.5 Mbps 720x480(59.94i) 720x576(50i) Audio AAC128 k/64 k/32 k 5/3/1.5/0.8/0.3/0.2 Mbps 480x270(29.97p/25p) Audio AAC 32k 0.2 Mbps

Accessories

Accessories	
Warranty Card (U model only)	1
Anti-reflective Film	1
INSTRUCTIONS	1
Documents and Software Disc	1
Viewfinder	1
Microphone	1
Lens 890 850	1

Dimensional Outline Drawing (Unit: mm)

GY-HM890U/GY-HM890CHU/GY-HM850U/GY-HM850CHU

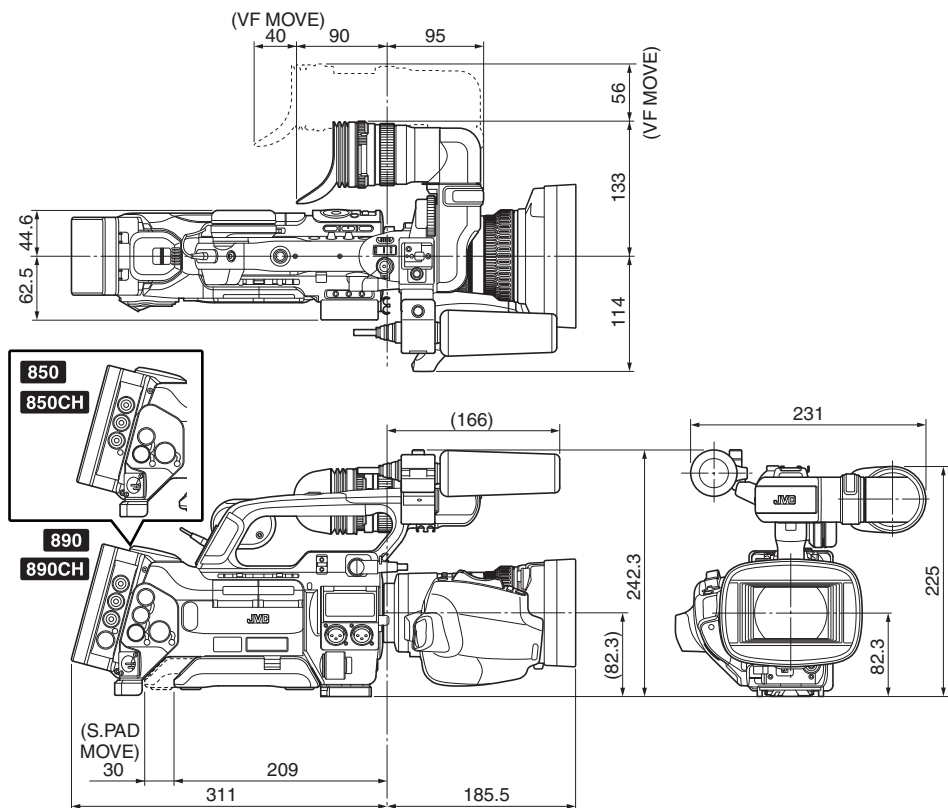

**GY-HM890E/GY-HM890CHE/GY-HM850E/GY-HM850CHE/
GY-HM890RE/GY-HM890RCHE/GY-HM850RE/GY-HM850RCHE**

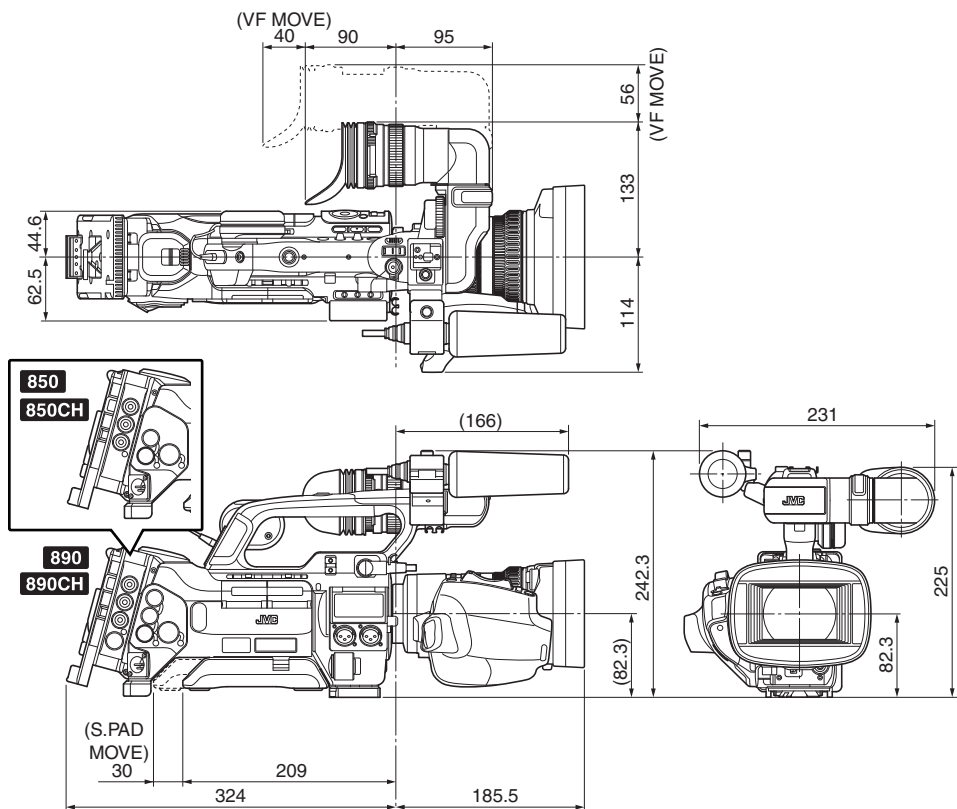

* The specifications and appearance of this product are subject to changes for further improvement without prior notice.

Index

- A** AC adapter 30
- Access point 175
- Action 96
- Anti-reflective film 30
- Aspect ratio 50
- B** Back focus 41
- Backup rec 87
- Battery 15, 31
- Brightness adjustment 57
- C** Camera mode 19, 36, 145
- Cellular adapter 177
- Clip continuous rec 89
- Clip cutter trig (splitting clips) 85
- Clip name 47, 95
- Clip review 83
- Color bar 155
- Color matrix 156
- Computer 160
- Connection settings file 197
- Continuous operating time 31
- D** Deleting clips 98
- Display screen 36, 145, 151
- Dual rec 85
- E** Earphone 72, 163
- Editing clip metadata 184
- Error message 64, 202
- Expanded focus 55
- External monitor 161
- F** Face detection 56
- Favorites menu 142
- File format 50
- Focus 53
- Focus assist 55
- Formatting (initializing) SD cards 45
- Frame rec 91
- FTP server 97, 178, 180
- G** Gain adjustment 59
- Genlock 126, 169
- GPS 15, 82, 147
- Grid marker 121, 154
- H** Histogram 84, 123
- I** Image stabilizer 68
- Initial settings 34
- Interval rec 92
- Iris adjustment 58
- L** LCD monitor 15, 32, 36, 39
- Lens cover 29
- Live streaming 199
- M** Marker display 154
- Media mode 19, 37, 151
- Menu 103, 104, 107
- Menu lock 106
- Metadata 178, 183
- Monitor speaker 40
- N** ND filter 62
- Network 149, 174
- Network operating environment 174
- O** OK mark 99
- One push auto focus 54
- Operation lock 48
- P** P2P 176
- Picture file 157
- Picture quality setting 68
- Power 32, 33
- Pre rec 89
- Preset zoom 52
- Preset zoom (camera) 52
- Preset zoom (web browser) 191
- Push auto focus 54
- R** Recordable time 43
- Remote control unit 24, 164
- Remote edit mode 19, 38
- Resolution 50
- Restoring SD card 46
- Return Videos 127, 172
- S** Safety zone display 154
- SD/SDHC/SDXC card 16, 43
- SDI input 24, 132, 168
- Selecting multiple clips 100
- Setting the date/time 35
- Setup file 157
- Shooting 49
- Skin detail function 155
- Software keyboard 105
- Spot meter 80
- Status screen 37, 153
- Studio system 172
- Switching shutter mode 60

	Switching shutter speed	60
T	Tally lamp	42, 206
	Thumbnail (detailed screen)	96
	Thumbnail (standard screen)	94
	Thumbnail screen	94
	Time code	72, 73, 78
	Time code generator	73
	Time code playback	98
	Trimming	102
U	USB mode	19, 38, 160
	User button	42
	User's bit	72
V	Variable frame rec	93
	Video format	50
	View remote	190
	Viewfinder	15, 32, 36, 40
W	Warning	38, 206
	White balance adjustment	63
	White paint	65
	White shading	66, 118
	Wired LAN	177
	Wired remote control	164
	Wireless LAN	175
Z	Zebra pattern	79
	Zoom	52
Symbol		
	4 channel (audio)	69, 127

Software License Agreement

The software embedded in the Product (hereinafter the “Licensed Software”) provided by JVC KENWOOD Corporation (hereinafter the “Licensor”) is copyrighted to or sublicensable by the Licensor, and this Agreement provides for the terms and conditions which Users shall follow in order to use the Licensed Software. The User shall use the Licensed Software by agreeing with the terms of this Software License Agreement. This Agreement shall be deemed completed at the time the User (hereinafter the “User”) initially used the Product in which the “Licensed Software” is embedded.

The Licensed Software may include the software which has been licensed to the Licensor directly or indirectly from any third party. In such case, some third parties require the Users to follow their conditions for use separately from this Software License Agreement. Such software shall not be subject to this Agreement, and the Users are urged to read the “[Important Notice concerning the Software] (P 217)” to be provided separately.

Article 1 General Provision

The Licensor shall grant to the User a non-exclusive and non-transferable (other than the exceptional case referred to in Article 3, Paragraph 1) licensed to use the Licensed Software within the country of the User (the country where the User bought the Product (hereinafter the “Country”).

Article 2 License

1. The license granted under this Agreement shall be the right to use the Licensed Software in the Product.
2. The User shall not duplicate, copy, modify, add, translate or otherwise alter, or lease the Licensed Software and any related documents, whether in whole or in part.
3. The use of the Licensed Software shall be limited to personal purpose, and the Licensed Software shall not be distributed, licensed or sub-licensed whether it is for commercial purpose or not.
4. The User shall use the Licensed Software according to the directions described in the operation manual or help file, and is prohibited to use or duplicate any data in a manner violating the Copyright Law or any other laws and regulations by applying whole or a part of the Licensed Software.

Article 3 Conditions for Grant of License

1. When the User transfers the Product, it may also transfer the license to use the Licensed Software embedded in the Product (including any related materials, updates and upgrades) on condition that no original, copies or related materials continue in the possession of the User, and that the User shall cause the transferee to comply with this Software License Agreement.
2. The User shall not carry out reverse engineering, disassembling, decompiling or any other code analysis works in connection with the Licensed Software.

Article 4 Right pertaining to the Licensed Software

1. Any and all copyrights and other rights pertaining to the Licensed Software and related documents shall belong to the Licensor or the original holder of the right who granted to the Licensor the license or sublicense for the Licensed Software (hereinafter the “Original Rightholder”), and the User shall not be entitled to any right other than the license granted hereunder, in respect of the Licensed Software and any related documents.
2. The User shall, whenever the User uses the Licensed Software, comply with any laws relating to the copyright and other intellectual property rights.

Article 5 Indemnification of Licensor

1. Neither the Licensor nor the Original Rightholder shall be liable for any damage incurred by the User or any third party due to the exercise of the license granted to the User under this Agreement, unless otherwise restricted by law.
2. The Licensor will offer no guarantee for the merchantability, convertibility and consistency with certain objective of the Licensed Software.

Article 6 Liability to Third Party

If any dispute has arisen with any third party due to an infringement upon a copyright, patent or any other intellectual property right that was caused by the User’s use of the Licensed Software, the User shall settle such dispute at the User’s own cost and hold the Licensor and the Original Rightholder harmless from any inconvenience it may cause.

Article 7 Confidentiality

The User shall keep the confidentiality of such portion of the Licensed Software, related documents thereof or any other information to be granted under this Agreement, as well as the conditions of this Agreement as has not yet entered the public domain, and shall not disclose or divulge the same to any third party without approval of the Licensor.

Article 8 Termination

In case the User falls under any of the events described in the following items, the Licensor may immediately terminate this Agreement or claim that the User compensates for the damage incurred by the Licensor due to such event:

- (1) when the User violated any provision of this Agreement; or
- (2) when a petition has been filed against the User for an attachment, provisional attachment, provisional disposition or any other compulsory execution.

Article 9 Destruction of the Licensed Software

If this Agreement is terminated pursuant to the provision of Article 8, the User shall destroy the Licensed Software, any related documents and copies thereof within two (2) weeks from such date of termination.

Article 10 Export Restriction

1. The User shall understand that the Licensed Software shall be subject to the export restrictions adopted by the country of User and any other countries.
2. The User shall agree that the software will be subject to any and all applicable international and domestic laws including the export control regulation of the country of User and any other countries, and any restrictions concerning the end-users, the use by end-users and importing countries to be provided by the country of User and any other countries, and any other governmental authorities.
3. If the User is an agency of the United States of America (the "Government"), the User acknowledge Licensor's representation that the Licensed Software is a "Commercial Item" as defined in Federal Acquisition Regulation (FAR) part 2.101(g) consisting unpublished "Commercial Computer Software" as those items are used at FAR part 12.212 and is only license the User with the same use right Licensor grants all commercial end users pursuant to the terms of this Agreement.

Article 11 Miscellaneous

1. In the event any part of this Agreement is invalidated by operation of law, the residual provisions shall continue in force.
2. Matters not stipulated in this Agreement or any ambiguity or question raised in the construction of this Agreement shall be provided or settled upon good-faith consultation between the Licensor and the User.
3. The Licensor and the User hereby agree that this Agreement is governed by the laws of Japan, and any dispute arising from, and relating to the rights and obligations under, this Agreement shall be submitted to the exclusive jurisdiction of the Tokyo District Court for its first instance.

Important Notice concerning the Software

Software License Attached to the Product :

The Software embedded in the Product is composed of several independent software components, and in each of such individual components (hereinafter the "Licensed Software"), a copyright of either JVC KENWOOD Corporation (hereinafter "JVC") or a third party subsists. The Product uses the software component designated in the End-User License Agreement that was executed between JVC and a third party (hereinafter "EULA").

The Licensed Software covers those corresponding to free software, and, as a condition of distribution of the software component in executable format which is based on the license granted under the GNU General Public License or Lesser General Public License (hereinafter "GPL/LGPL"), it requires an availability of the source code for the relevant component. Please refer to the following URL concerning the distribution of the source code;

<http://www3.jvckenwood.com/english/download/gpl/index.html>

Please note that we are unable to answer any inquiry relating to the contents, etc. of the source code. In addition, the Licensed Software includes the software developed or created independently by JVC and there exists an ownership of JVC in such software and any accompanying documents, which is protected by the Copyright Law, any international treaties and other applicable laws. As to matters concerning the handling by JVC of the software components, please refer to the "Software License Agreement" attached hereto. Please note that any software component licensed under "EULA" which is not subject to "GPL/LGPL", and those developed or created independently by JVC shall not be subject to the requirement for provision of the source code. The software component distributed under "GPL/LGPL" shall be licensed to users without charge, and, therefore, no warranty is given for such software component, either express or implied, within the scope of the applicable laws and regulations. Unless otherwise permitted by applicable laws and regulations or agreed in written form, none of the owners of the copyright or persons entitled to alter or redistribute the software component under the said license shall have any liability for any type of damage or loss resulting from the use of or inability to use such software component. For further details of the conditions of use of such software component or matters required to be complied with, please refer to the relevant "GPL/LGPL".

Users are urged to read the details for the relevant license carefully before using the software component covered by "GPL/LGPL" and embedded in the Product. Since the terms and conditions of individual licenses are provided by parties other than JVC, the original English version will be displayed by the Product.

- ① Turn on the power.
- ② Press the [MENU/THUMB] button.
- ③ Select [Main Menu] → [System] → [System Information] → [Open Source License].

Open Source License

SGI FREE SOFTWARE LICENSE B (Version 2.0)

- OpenGL ES1.1 (Header file)
- EGL1.1 (Header file)

SGI FREE SOFTWARE LICENSE B (Version 2.0, Sept. 18, 2008)

Copyright © [dates of first publication] Silicon Graphics, Inc. All Rights Reserved.

Permission is hereby granted, free of charge, to any person obtaining a copy of this software and associated documentation files (the "Software"), to deal in the Software without restriction, including without limitation the rights to use, copy, modify, merge, publish, distribute, sublicense, and/or sell copies of the Software, and to permit persons to whom the Software is furnished to do so, subject to the following conditions:

The above copyright notice including the dates of first publication and either this permission notice or a reference to <http://oss.sgi.com/projects/FreeB/> shall be included in all copies or substantial portions of the Software.

THE SOFTWARE IS PROVIDED "AS IS", WITHOUT WARRANTY OF ANY KIND, EXPRESS OR IMPLIED, INCLUDING BUT NOT LIMITED TO THE WARRANTIES OF MERCHANTABILITY, FITNESS FOR A PARTICULAR PURPOSE AND NONINFRINGEMENT. IN NO EVENT SHALL SILICON GRAPHICS, INC. BE LIABLE FOR ANY CLAIM, DAMAGES OR OTHER LIABILITY, WHETHER IN AN ACTION OF CONTRACT, TORT OR OTHERWISE, ARISING FROM, OUT OF OR IN CONNECTION WITH THE SOFTWARE OR THE USE OR OTHER DEALINGS IN THE SOFTWARE.

Except as contained in this notice, the name of Silicon Graphics, Inc. shall not be used in advertising or otherwise to promote the sale, use or other dealings in this Software without prior written authorization from Silicon Graphics, Inc.

GY-HM890U/GY-HM890E/GY-HM890CHU/GY-HM890CHE/GY-HM890RE/GY-HM890RCHE/
GY-HM850U/GY-HM850E/GY-HM850CHU/GY-HM850CHE/GY-HM850RE/GY-HM850RCHE
HD MEMORY CARD CAMERA RECORDER

JVC